



# Wind Studio Olivari 2003

Il susseguirsi di curve che si muovono in maniera aggraziata e filante disegna una maniglia moderna e dinamica, piacevole da guardare, ma anche da impugnare.

A sequence of shapely curves moving in a sweeping manner makes for a modern and dynamic handle that is pleasing to the eye and comfortable to the hand.

M187



CR Cromo lucido/Bright chrome



ZL SuperOro lucido/  
SuperGold bright



CO Cromo satinato/Satin chrome



TS SuperOro satinato/  
SuperGold satin

C187



K187









# Onda Nicola Novelletto 1998

Nel caso di Onda, la ricerca è stata di tipo puramente ergonomico: un'plorazione dei movimenti che compie la mano, delle pressioni che esercita, dei movimenti che svolge, della sua fisicità. Non deve stupire l'equilibrio tra classicità e modernità poiché la mano umana non si è evoluta, è sempre uguale a se stessa: molti strumenti moderni sono simili, se non proprio l'esatta replica di quelli usati migliaia di anni fa. Come effetto si ottiene una gradevole sensazione di facilità, adesione e accompagnamento, che ha ne suggerito il nome. *Nicola Novelletto*

For the Onda handle, the studies I made were purely ergonomic. I analysed the movements of the hand, the pressure it exerts and its physicality. It is no wonder that the result is a balance between classic and modern, because the human hand has not evolved – it has always been the same as it is now. Many modern tools are similar, if not exact replicas of ones used thousands of years ago. The final effect is a pleasant sensation of ease, adhesion and accompaniment, which is what suggested the name Onda, Italian for “wave”. *Nicola Novelletto*

M175



CR Cromo lucido/Bright chrome



CO Cromo satinato/Satin chrome



ZL SuperOro lucido/  
SuperGold bright



TS SuperOro satinato/  
SuperGold satin



NL SuperNichel lucido/  
SuperNickel bright



IS SuperInox satinato/  
SuperStainlessSteel satin



RS SuperRame satinato/  
SuperCopper satin



DS SuperBronzo satinato/  
SuperBronze satin

C175



K175











# Novella Novelletto, Volonterio 1996

Novella è stata disegnata insieme a Roberto Volonterio che ricordo con affetto. Eravamo entrambi dei 'novellini' in questo settore e fu una piacevole sorpresa fare centro alla prima prova: ci caricò di entusiasmo. Ricordo che i nostri disegni (a matita!) erano talmente elementari che i primi modelli realizzati in azienda non colsero alcune superfici e preferimmo studiarli nei minimi dettagli in un modello. Da allora presentammo tutti i progetti in forma di modello. Vorrei ricordare il signor Barbaglia, capo officina, che contribuì alla definizione della bella cremonese e col quale, superata la 'diffidenza' iniziale, si costruì un bel rapporto di collaborazione e stima. La linea è estremamente semplice e liscia, ispirata a una foglia d'ulivo: le superfici leggermente curve e morbide e la presa, delicata e fluida. Ammetto che ancora mi stupisce vedere come resista al tempo dopo oltre vent'anni!

Nicola Novelletto

In 1994, I designed the Novella handle together with Roberto Volonterio, whom I remember with great fondness. We were both beginners (*novellini*, in Italian) in this field, so it was a pleasant surprise to be met with success at our first try – it made us very enthusiastic. I remember that our first (pencil!) drawings were so elementary that the first models the company made did not even include some of the surfaces we intended them to have. So we decided to study them on our own in every last detail by making our own model. After that, we always presented our designs in a model. I'd like to mention signor Barbaglia, the workshop supervisor, who contributed to the definition of the beautiful lever handle. We established a wonderful relationship of collaboration and esteem with him after an initial moment of mutual "wariness". The simple, smooth line of the handle was inspired by the leaf of an olive tree, seen in its gently curved surfaces and delicate, fluid grip. That was over 20 years ago. I admit that I am still amazed at its longevity! Nicola Novelletto

M165



CR Cromo lucido/Bright chrome



ZL SuperOro lucido/  
SuperGold bright



IS SuperInox satinato/  
SuperStainlessSteel satin



CO Cromo satinato/Satin chrome



TS SuperOro satinato/  
SuperGold satin



DS SuperBronzo satinato/  
SuperBronze satin

C165



K165









# Nirvana Massimo Iosa Ghini 1997

Nel modello Nirvana, la pulsione di Massimo Iosa Ghini per la componente aerodinamica del segno si esprime con evidenza nella soluzione scelta per il raccordo tra il mozzo e la leva. La torsione e il dinamismo impresso nel punto in cui si incontrano, lo slancio della leva, la linea filante del loro innesto (riducendosi di sezione il mozzo, la leva acquista dinamismo) sono elementi espressivi di questa sua passione per la velocità e il movimento che lo caratterizza fin dai suoi esordi "bolidisti".

The Nirvana model expresses Massimo Iosa Ghini's attraction for the aerodynamic component of signs. The solution he chose for the joint between the shaft and the lever contains torsion and movement. The lift of the lever, the flow of the line where they meet, and the small section of the shaft converge to give a dynamic character to the handle, a design that communicates Iosa Ghini's love of speed and his early roots in the Italian design trend called *bolidismo*.

M173



CR Cromo lucido/Bright chrome



CO Cromo satinato/Satin chrome



ZL SuperOro lucido/  
SuperGold bright

C173



K173











# Agata Albini, Helg 1965

Nell'immaginare un oggetto funzionale al gesto di afferrare una leva per innescare un'azione e trasformare lo spazio – aprirlo o chiuderlo – Franco Albini e Franca Helg disegnano una maniglia con la leggerezza di un'ala di uccello o di un profilo di un fiore, imboccando una direzione espressiva di contenuta organicità. Il suo disegno riflette l'appassionata ricerca di un punto di equilibrio tra qualcosa e il suo opposto: tra sensualità e linearità geometrica, tra solidità e leggerezza, tra esattezza grafica del segno e consistenza volumetrica della materia. Tutti i caratteri tipici della ricerca formale di Albini ed Helg sono riconoscibili anche in questo piccolo oggetto misurato sulla scala della mano: l'alleggerimento del materiale, la ricerca di una linea fluente, le geometrie filiformi, una certa propensione per forme affusolate, la precisione, la sottile eleganza moderna e classica nello stesso tempo. Tra le maniglie ergonomiche è un classico del buon design italiano.

In their imagining an object functional to the gesture of gripping a lever to trigger an action that transforms the space by opening or closing, Franco Albini and Franca Helg designed a handle with the lightness of a bird's wing, and the profile of a flower. They travelled a road directed toward the expression of organic shapes. The Agata handle reflects their keen search for a point of equilibrium between one thing and its opposite – between a sensual organic mood and geometric linearity; between solidity and lightness; between a precise graphic mark and the volumetric consistency of the material. All the typical qualities of Albini and Helg's experimentation with form are recognisable in this small object proportioned to the scale of a hand: making the material lighter; the search for fluid lines; slender geometric shapes; a certain propensity for tapered forms; exactitude; and subtle elegance that is modern and classic at the same time. Among ergonomic handles, this is a classic of good Italian design.

M116



CR Cromo lucido/Bright chrome



CO Cromo satinato/Satin chrome



ZL SuperOro lucido/  
SuperGold bright

C116



K116



- 1\_ Franco Albini, Tre Pezzi poltrona/armchair, Poggi 1959
- 2\_ Franco Albini, Margherita, poltrona/armchair, Vittorio Bonacina 1956
- 3\_ Franco Albini, Fiorenza poltrona/armchair, Arflex 1952-1955
- 4\_ La Rinascente: scala/staircase, Roma 1957
- 5\_ Franco Albini, 'Stanza per un Uomo', VI Triennale di Milano 1936
- 6\_ Linea 1 della Metropolitana Milanese: corrimano/Milan Metro Line One: handrail, (F.Albini, F.Helg, A.Piva, B. Noorda) 1962-1964







# Siena

Novelletto, Volonterio 1997

Le maniglie Siena e Orvieto, ideate con Roberto Volonterio, nascono entrambe da una ricerca sulle forme "classiche". Non è stato semplice trovare le proporzioni e gli equilibri che le rendessero contemporanee pur conservando i segni della tradizione e la memoria del passato. I due modelli, pur essendo alternativi, si completano rimanendo nell'ambito della tradizione. *Nicola Novelletto*

The Siena and Orvieto handles are based on a study of classic forms. It was not easy to find the right proportions and proper balance that would make them contemporary while preserving the mark of tradition and the memory of the past. Although alternatives, the two models complement each other in the ambit of established familiarity. *Nicola Novelletto*

M169



CR Cromo lucido/Bright chrome



CO Cromo satinato/Satin chrome



ZL SuperOro lucido/  
SuperGold bright



TS SuperOro satinato/  
SuperGold satin



DS SuperBronzo satinato/  
SuperBronze satin

C169



K169









# Orvieto

Novelletto, Volonterio 1997

M170



CR Cromo lucido/Bright chrome



CO Cromo satinato/Satin chrome



ZL SuperOro lucido/  
SuperGold bright



TS SuperOro satinato/  
SuperGold satin



DS SuperBronzo satinato/  
SuperBronze satin

C170



K170











## Icaro Paolo Portoghesi 1997

Era una mia aspirazione, da quando ho cominciato a costruire, poter usare delle maniglie coerenti con la mia concezione dell'architettura come arte dell'accoglienza. Uno dei primi atti che compie chi entra in un edificio è quello di aprire delle porte. Lì avviene il primo contatto fisico, lì si "tocca" l'edificio. La maniglia è quindi anche l'introduzione tattile all'architettura e per un architetto che pensa, progettando, ci si debba rivolgere a tutti e cinque i sensi, questo contatto acquista una grande importanza. Ho cercato quindi di "dare la mano" a chi entra con un oggetto insieme piacevole e moderatamente espressivo. Ho cercato di fargli sentire, increspando lievemente la superficie come quella di una foglia, o dell'ala di un uccello, qualcosa di vibrante, di vivo. Olivari ha fatto il resto con la consueta eleganza. *Paolo Portoghesi*

Ever since I started building, it had been an aspiration of mine to be able to use door handles that were coherent with my idea of architecture as the art of welcoming. One of the first things a person does when entering a building is open the door. That is where the first physical contact takes place, where you "touch" the building. So the handle is a tactile introduction to it. For an architect like me, who thinks that design should involve all five senses, this contact acquires great importance. I attempted to give people entering "a handshake" by offering them a handle that is at once pleasing and moderately expressive. By rippling the surface slightly, like a leaf or the wing of a bird, my aim was to have them feel something vibrant and alive. Olivari did the rest, with its habitual elegance. *Paolo Portoghesi*

M168



ZL SuperOro lucido/  
SuperGold bright

C168



K168



1\_Tea&Coffee Piazza, Alessi  
1979-1983  
2\_posate d'argento/ silver  
cutlery, Cleto Munari 1984  
3\_Nuova Chiesa, Calcata 2009  
4\_Grande Moschea di Roma,  
1974



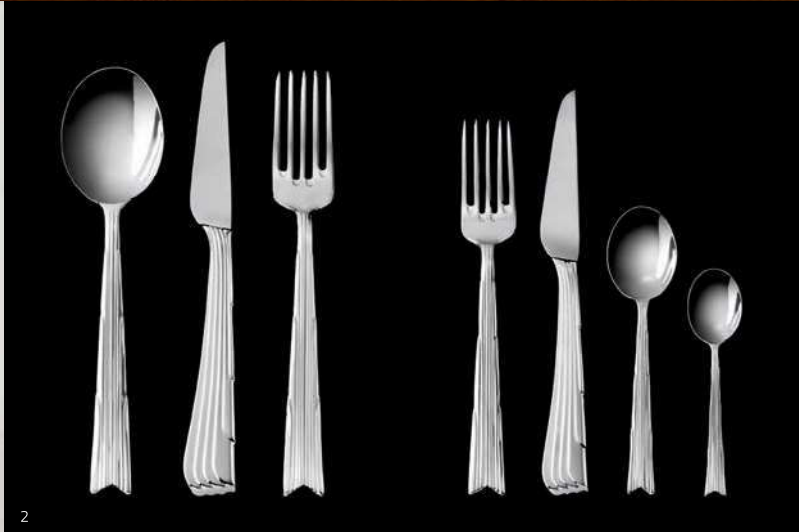



# Bond Andrea Branzi 1994

L'idea di questa maniglia nasce dal desiderio di evadere dalla geometria e dall'ergonomia tradizionale di questo strumento domestico trasformandolo in una forma accogliente attorno a cui si avvolge la nostra mano. Il nome fa riferimento ai manganelli di gomma che vediamo nei film polizieschi o nei cartoni animati. Il metallo, senza spigoli, sembra diventare un materiale morbido e rassicurante: come la gomma appunto. Un filo di ironia nel progetto di design serve sempre a uscire dai rigori della nostra idea calvinista della Modernità. *Andrea Branzi*

The idea behind this handle is the desire to escape from the geometry and traditional ergonomics of this domestic instrument, and transform it into a welcoming form around which to wrap our hand. The name is a reference to the rubber police batons you see in spy movies and cartoons. The smooth-edged metal seems to become a soft, reassuring material, just like rubber. A bit of wit in design projects is always useful to get away from the punctiliousness of our Calvinistic idea of modernity. *Andrea Branzi*

M163



CO Cromo satinato/Satin chrome



ZL SuperOro lucido/  
SuperGold bright

C163



K163



- 1\_Berione libreria/bookshelf, Cassina 1988 (ph studio Marconi)
- 2\_Blister vaso/vase, Design Gallery 2004
- 3\_ "Andrea Branzi, Open Enclosures", Fondation Cartier pour l'art contemporain, Paris, 2008 (courtesy Fondation Cartier pour l'art contemporain)

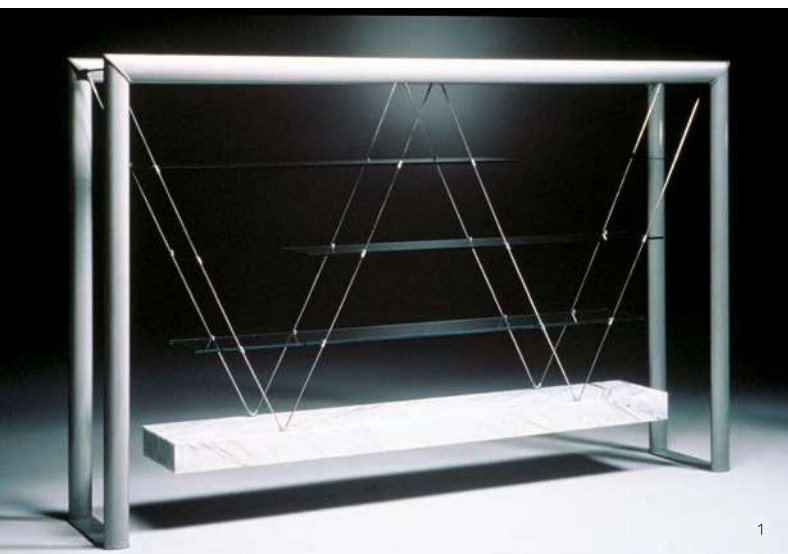

1



2

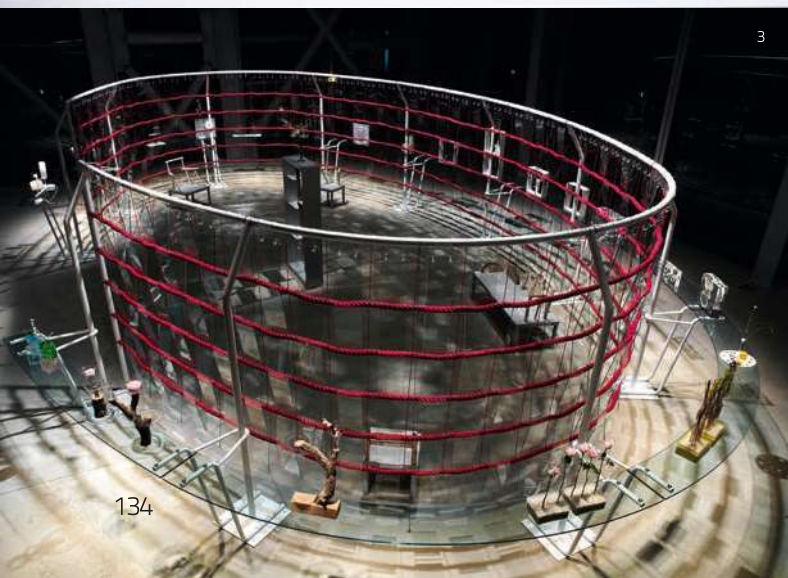

3







# Golia Studio Olivari 1994

Lo Studio Olivari, mettendo a punto una serie di forme semplici, misurate, gradevoli e adatte per i giovani, tra le prime ha ideato Golia, una maniglia che ha immediatamente riscosso il favore del pubblico, per il suo essere adatta a tutti gli ambienti della casa.

Studio Olivari, developing a series of simple, measured, pleasing and suitable forms for young people, among the first designed Golia, a handle that immediately gained the public's favor, for its adaptation to all environments of the house.

M160



CR Cromo lucido/Bright chrome



CO Cromo satinato/Satin chrome



ZL SuperOro lucido/  
SuperGold bright



DS SuperBronzo satinato/  
SuperBronze satin

C160



K160





# Emilia Studio Olivari 1996

A metà degli anni '50 si era realizzata con l' arch. Vico Magistretti la maniglia Torre Parco, espressamente per l' edificio di 20 piani da lui progettato con Franco Longoni in prossimità della Triennale di Milano. Emilia è una sua versione più moderna e addolcita, che l' architetto ha affidato alla responsabilità dello Studio Olivari.

In the mid 1950s it was realized with arch. Vico Magistretti handles Park Tower, specifically for the 20 floors building he designed with Franco Longoni near the Triennale of Milan. Emilia is its most modern and sweet version, which the architect has entrusted to the responsibility of Studio Olivari.

M167



CR Cromo lucido/Bright chrome



CO Cromo satinato/Satin chrome



ZL SuperOro lucido/  
SuperGold bright



TS SuperOro satinato/  
SuperGold satin



DS SuperBronzo satinato/  
SuperBronze satin

C167



K167





# Polo Rodolfo Bonetto 1991

Rodolfo Bonetto, disegnatore autodidatta, con la passione della batteria e del jazz, ha espresso il proprio stile attraverso un'innumerabile serie di oggetti: macchine utensili, elettrodomestici, orologi, telefoni, calcolatori, scarponi da sci, laser chirurgici. Un campo dove si è particolarmente distinto è lo studio degli interni delle automobili dove la componente stilistica (la continuità di materia e forma) si fonde con esigenze di tipo ergonomico e tecnico: un approccio ulmiano riconoscibile anche nel disegno della maniglia Polo. La sua geometria è, infatti, tutta giocata sulla modulazione di un'unica sezione ovale che, nel compiere una rotazione di novanta gradi, dà corpo all'immagine dell'impugnatura: la matrice formale è un ovale pressoché dello stesso diametro della rosetta. La rigorosa impostazione geometrica però si trasforma nel momento in cui si adatta al gesto della mano che afferra, rompendo la simmetria formale e generando una forma impercettibilmente disassata nel rispetto delle regole dell'ergonomia.

Bonetto was a self-taught designer with a love of jazz and playing the drums. He expressed his style in a countless number of objects, including machine tools, household appliances, alarm clocks, telephones, calculators, ski boots and surgical lasers. One of his particular fields of interest was the design of automobile interiors, where he combined the stylistic continuity of material and form with ergonomic and technical requirements. That approach contained elements of design theory as it was taught at Ulm, which are also recognisable in the Polo handle. Its geometry is based on the modulation of a single oval section. As the handle bends by 90 degrees, it gives body to the image of the lever. The formal matrix is an oval with almost the same diameter as the rosette. The strict geometric outline is transformed by adapting to the gesture of the hand as it grips, breaking the formal symmetry and generating an imperceptibly offset shape that respects the rules of ergonomics.

M152

C152

K152



CR Cromo lucido/Bright chrome



CO Cromo satinato/Satin chrome



- 1\_Autovox Linea 1, 1969
- 2\_Aki portaombrelli/umbrellas holder, B-line 1975
- 3\_Boomerang poltrona/armchair, Flexform 1968
- 4\_Quattro Quarti tavolini/nesting tables, Bernini 1969



1

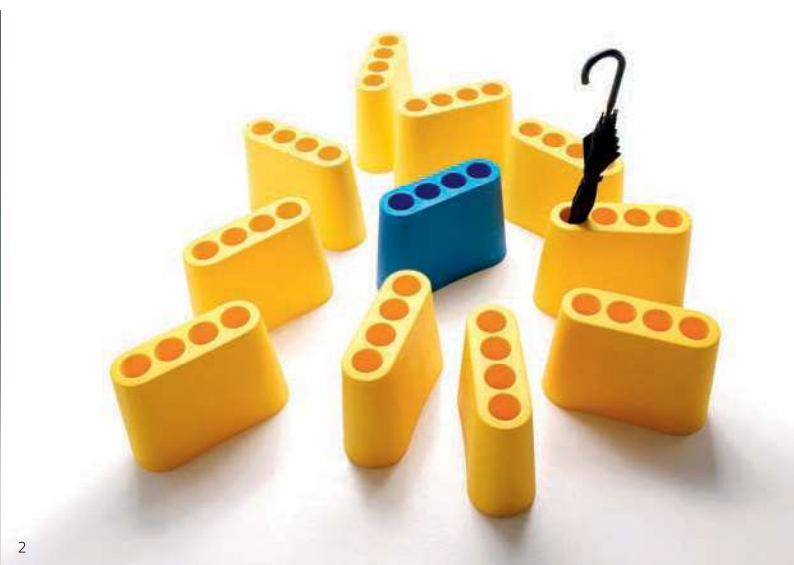

2



3



4









# Flaminia Studio Olivari 1994

Flaminia è una delle maniglie prodotte dalla ricerca di forme semplici, adatte a un pubblico giovane: a distanza di anni mantiene una precisa validità formale e una piacevole ergonomia.

Flaminia is one of the handles produced by the search for simple shapes, suitable for a young audience: after years it keeps a precise formal validity and a pleasant ergonomics.

M159



CR Cromo lucido/Bright chrome



CO Cromo satinato/Satin chrome



ZL SuperOro lucido/  
SuperGold bright



TS SuperOro satinato/  
SuperGold satin



DS SuperBronzo satinato/  
SuperBronze satin

C159



K159





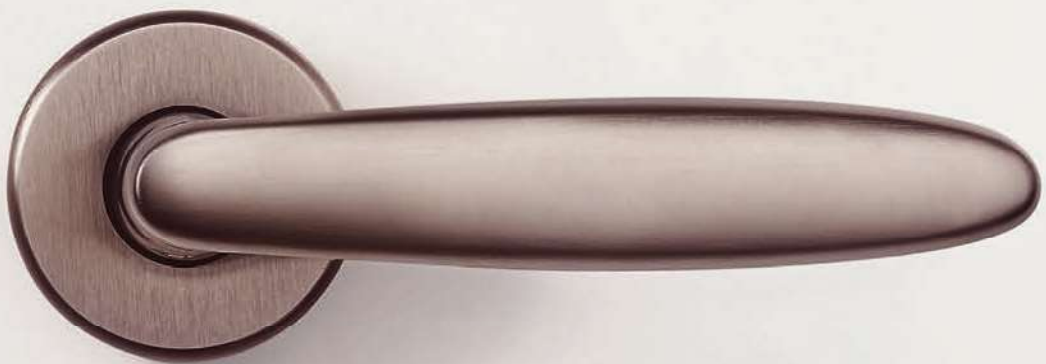



# Comet Nicola Novelletto 2001

L'idea di Comet è venuta pensando al movimento, a un corpo levigato che si muove senza attriti e resistenze. Questa premessa ha portato a un fuso liscio che può essere impugnato in modo naturale per trasmettere una sensazione di fluidità. La linea di separazione e l'abbinamento di due finiture permettono di far apprezzare ancora di più la forma della maniglia. *Nicola Novelletto*

The idea for Comet is movement: a smooth unit moving without friction or resistance. This resulted in a streamlined spindle shape that forms a natural handgrip while transmitting a feeling of fluidity. The separation line and a combination of two finishes exalt the handle's form. *Nicola Novelletto*

M183



CA Cromo lucido-satinato/  
Chrome bright-satin



CN Cromo lucido-SuperNichel satinato/  
Bright chrome-SuperNickel satin



ZT SuperOro lucido-satinato/  
SuperGold bright-satin

C183



K183







# Sector Studio Olivari 2002

Frutto della ricerca dello Studio Olivari su forme icastiche ma non invasive, Aurelia si è evoluta e completata con una versione più caratterizzata - Sector - per esprimere la propria natura moderna e decisa.

The result of Studio Olivari's research on icastic but non-invasive forms, Aurelia has evolved and completed with a more distinctive version - Sector - to express its modern and decisive nature.

M186



CA Cromo lucido-satinato/  
Chrome bright-satin



ZT SuperOro lucido-satinato/  
SuperGold bright-satin

C186



K186





# Aurelia

Studio Olivari 2002

M185



CR Cromo lucido/Bright chrome



CO Cromo satinato/Satin chrome



ZL SuperOro lucido/  
SuperGold bright



TS SuperOro satinato/  
SuperGold satin



NL SuperNichel lucido/  
SuperNickel bright



NS SuperNichel satinato/  
SuperNickel satin



IS SuperInox satinato/  
SuperStainlessSteel satin



RS SuperRame satinato/  
SuperCopper satin



DS SuperBronzo satinato/  
SuperBronze satin



US SuperAntracite satinato/  
SuperAnthraccite satin

C185



K185





# Aster Studio Olivari 1998

M174



CA Cromo lucido-satinato/  
Chrome bright-satin



CE Cromo lucido-poliestere nero/  
Bright chrome-black polyester



ZT SuperOro lucido-satinato/  
SuperGold bright-satin

C174



K174



Tra le maniglie nate dalla ricerca di forme semplici, adatte a un pubblico giovane, Futura ha incontrato il maggior successo, per la sua forma dinamica e slanciata. La versione Aster, attraverso la bi-finitura, permette interessanti possibilità di espressione e personalizzazione.

Among the handles born from the search for simple shapes, suitable for a young audience, Futura has met the greatest success, for its dynamic and slender form. The Aster version, through the bi-finishing, offers interesting possibilities of expression and customization.



# Futura

Studio Olivari 1997

M172



CR Cromo lucido/Bright chrome



ZL SuperOro lucido/  
SuperGold bright



NS SuperNichel satinato/  
SuperNickel satin



CO Cromo satinato/Satin chrome



IS SuperInnox satinato/  
SuperStainlessSteel satin

C172



K172





# Garda Ignazio Gardella 1951

Quando nel 1949 Ignazio Gardella progetta una delle sue architetture più celebri – il condominio di via Marchiondi a Milano firmata con Anna Castelli Ferrieri e Roberto Menghi – tutto è disegnato con maestria di dettaglio. Olivari è coinvolta per quanto riguarda la realizzazione delle maniglie e da questa collaborazione, centrata su un'idea di architettura in cui ogni parte, anche la più minuta, partecipa al disegno di un insieme organico, nasce la serie Garda. Per la sua linea essenziale dal linguaggio asciutto, Gardella dichiara di prendere ispirazione all'architetto razionalista tedesco Ferdinand Kramer che aveva partecipato alle visioni urbane della *Neue Frankfurt* di Ernst May disegnando una maniglia dalla geometria elementare. Gardella studia le proporzioni della sua maniglia a partire da un elemento cilindrico: progressivamente si svasa assumendo forma di cono con la stessa astratta eleganza che contraddistingue la sua architettura.

When in 1949 Ignazio Gardella began working on one of his most famous pieces of architecture, the apartment complex at Via Marchiondi 7 in Milan, designed with Anna Castelli Ferrieri and Roberto Menghi, every last detail was skilfully crafted. Olivari was involved for the production of the door handles, and this collaboration – centred on an idea of architecture in which every part, no matter how small, contributed toward the aim of an organic whole – led to the creation of the Garda series. For its clean lines and lean visual language, Gardella declared to have taken inspiration from the German functionalist architect Ferdinand Kramer, who had participated under the project leader Ernst May in the new city plan for Frankfurt (*Das Neue Frankfurt*, 1925-1930) by designing a utilitarian, geometric door handle. Gardella studied the proportions of his own handle by starting with a cylindrical element that progressively widens toward the end of the lever, taking on a conical shape with the same elementary elegance that distinguishes his architecture.

M105



CR Cromo lucido/Bright chrome



CO Cromo satinato/Satin chrome



ZL SuperOro lucido/  
SuperGold bright



DS SuperBronzo satinato/  
SuperBronze satin

C105



K105



1\_Dispensario antitubercolare / Tuberculosis sanatorium, Alessandria 1934-1938

2\_Ignazio Gardella, Franco Albini, Quartiere Mangiagalli, Milano 1950-1952

3\_LTA3 Arenzano lampada/light, Azucena 1956

4\_tavolo esposto alla X Triennale di Milano/table exhibited at X Triennale di Milano, 1954

5\_Digamma poltrona/armchair, Gavina 1950

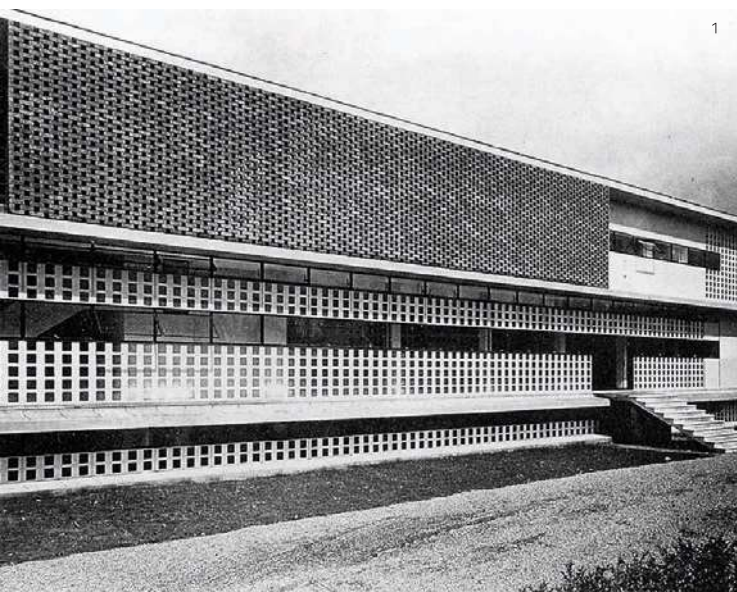

1



2



3



4



5







# Sibilla

Vico Magistretti 1992

Ricordo che quando andai allo studio di Vico Magistretti per concordare il progetto della sua nuova maniglia, mentre discorrevamo seduti intorno al grande tavolo che occupava quasi tutta la stanza, la schizzava davanti a me, istintivamente, fissandola in una forma pressoché definitiva. La sua idea era quella di realizzare un oggetto ergonomico e nello stesso tempo slanciato. Mentre raccontava di quanto fosse interessante la forma di un osso, l'abbozzava con mano sicura. Subito dopo, cominciò a riflettere sul fatto che la dinamicità che desiderava ottenere, potesse essere espressa apportando un taglio alle due estremità, e poiché non erano simmetriche, i tagli dovevano seguire una differente inclinazione. "Prova a fare un campione seguendo questi schizzi", mi disse. "Vediamo se riuscite ad esprimere la mia idea". Al terzo prototipo si è detto soddisfatto ed è nata Sibilla. Questo era il metodo di lavoro di Vico: cercava un confronto immediato con i tecnici perché le sue intuizioni fossero realizzate al meglio. *Antonio Olivari*

I remember going to Magistretti's studio to talk about him designing a new handle. Sitting around a big table that practically took up the entire room, he sketched the Sibilla right before my eyes, practically fixing its definite form there and then. His idea was to make it an ergonomic object that also had verve. As he described how interesting he found the shape of a bone, he steadily drew one. Soon after, he began musing about how the dynamic effect he wished to obtain for the handle could be expressed by slicing off the two extremities. Seeing that they weren't symmetrical, the cuts needed to have different inclinations. "Try to make a sample along the lines of these sketches," he said to me. "Let's see if you succeed in expressing my idea." By the third prototype, he was satisfied. Sibilla was born. This is how Vico liked to work. He sought immediate answers from technicians so that his ideas would be made to their best potential. *Antonio Olivari*

M154



CR Cromo lucido/Bright chrome



CO Cromo satinato/Satin chrome

C154



K154



- 1\_Selene sedia/chair, Artemide 1968
- 2\_Atollo lampada/light, O-luce 1977
- 3\_Eclissi lampada/light, Artemide 1967
- 4\_Maralunga divano/sofa, Cassina 1973
- 5\_Nuvola Rossa libreria/bookshelf, Cassina 1977











# Marilyn MAD Architects 2016

Marilyn nasce dal linguaggio organico e sinuoso dello studio MAD Architects e del suo leader Ma Yansong. La forma morbida e flessuosa della maniglia ricorda il design innovativo delle *Absolute Towers* di Toronto, note tra gli abitanti del quartiere come *Marilyn Monroe Towers*. Un gesto semplice ed elegante innesca la torsione pronta ad accogliere ergonomicamente la mano nel gesto di afferrare la maniglia. Il design si bilancia nella ricerca di un equilibrio tra pieni, vuoti e diverse sfumature di ombre. Marilyn con le sue curve flessuose e funzionali enfatizza il livello di connessione tra architettura e industrial design.

Marilyn is part of the organic and sinuous design language wielded by MAD Architects and its leader, Ma Yansong. The soft, curvaceous shape of the handle is reminiscent of the innovative form used by MAD for the *Absolute Towers* in Toronto, which local residents have nicknamed the *Marilyn Monroe Towers*. Easy, elegant lines start off the twist to ergonomically meet the hand as it grips the lever. The approach is a balanced search for equilibrium between solids, voids and shadows of different depths. Marilyn's functional torsion emphasises the high level of connection between architecture and industrial design.

M252B



CR Cromo lucido/Bright chrome



CO Cromo satinato/Satin chrome



IS SuperInox satinato/  
SuperStainlessSteel satin



DS SuperBronzo satinato/  
SuperBronze satin



US SuperAntracite satinato/  
SuperAnthracite satin

C252



K252B



1\_Absolute Towers, Mississauga, Canada 2006-2012  
2\_Chaoyang Park Plaza, Beijing, China 2012-2016  
3\_Conrad Hotel, Beijing, China 2008-2013







# Conca Patricia Urquiola 2014

L'Hotel Mandarin Oriental di Barcellona è stata la prima occasione di collaborazione tra Patricia e noi. Da questo primo incontro nasce Conca, in due tempi e in due versioni. La prima, più grande, nata da un approccio scultoreo ed espressivo, è riservata solo all'hotel. La seconda, più raccolta, ripensata in termini di proporzioni, è entrata far parte del nostro catalogo. In entrambi i casi Patricia ha voluto proporre una maniglia importante, di carattere, ma nello stesso tempo leggera: da accarezzare, più che da impugnarne. *Antonio Olivari*

The Mandarin Oriental hotel in Barcelona was our first opportunity to work together with Patricia Urquiola. This is when the Conca was born, devised on two different occasions and in two different versions. The first is the larger one, with a sculptural and expressive approach – reserved for the hotel only. The second is more compact, with redesigned proportions, and is part of our range. In both cases, Urquiola wished to propose an important handle, one with character, yet light. More than a handgrip, it's a handle with a soft touch. *Antonio Olivari*

M236B



CR Cromo lucido/Bright chrome



CO Cromo satinato/Satin chrome



IS SuperInnox satinato/  
SuperStainlessSteel satin



RS SuperRame satinato/  
SuperCopper satin



DS SuperBronzo satinato/  
SuperBronze satin



US SuperAntracite satinato/  
SuperAnthracite satin

C236



K236B









# Uovo Studio Olivari 1957

Il modello Uovo è stato ideato da Ambrogio Olivari. Occorreva un pomolo piccolo, dalla forma elegante e per ottenerlo, come rivela il nome, ha semplicemente utilizzato un uovo.

Per la realizzazione si è preferito optare sulla fusione in conchiglia con anima in sabbia, una tecnica che consentiva di ottenere un'ampia superficie esterna e un corpo internamente cavo: per ridurre il materiale, contenere i costi e anche il peso (in modo da non gravare sulla serratura).

Il modello ha avuto grande successo ed è ancora a catalogo.

The Uovo (Italian for "egg") is the brainchild of Ambrogio Olivari.

We needed a small knob with an elegant shape. To obtain it, as the name reveals, he simply used an egg.

To produce it, we cast it using shell moulding with a sand core, a technique that allowed us to achieve a large exterior surface and a hollow body.

This reduced the amount of material needed, lowered costs and lightened the weight (in order to not weigh down on the mechanism).

The model was extremely successful and is still part of our range.

M108



CR Cromo lucido/Bright chrome



ZL SuperOro lucido/  
SuperGold bright



DS SuperBronzo satinato/  
SuperBronze satin



CO Cromo satinato/Satin chrome



TS SuperOro satinato/  
SuperGold satin



NP Nero opaco/Mat black

C108



K108

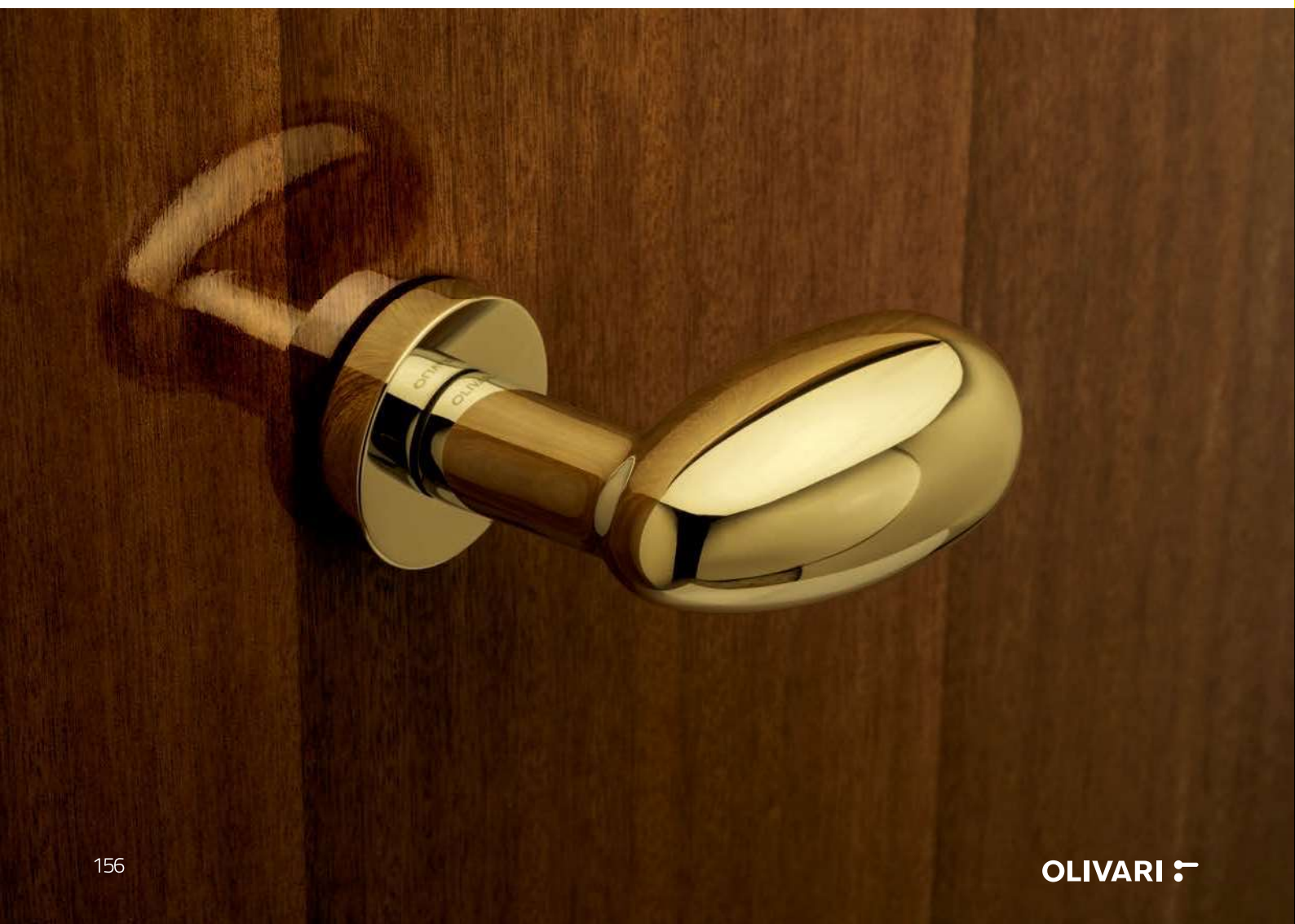





# Blindo Studio Olivari 1998

Ha una forma ovale ed elegante. Ottenuto per forgiatura a caldo, è perfettamente idoneo ai trattamenti di galvanica e pvd che lo rendono particolarmente adatto per l'utilizzo su porte pesanti ed esposte agli agenti atmosferici esterni.

Blindo has an oval and elegant shape. It is made by hot forging, and is perfectly suited to galvanizing and physical vapour deposition (PVD), making it good for heavy doors and exposure to outdoor conditions.

M178



CR Cromo lucido/Bright chrome



CO Cromo satinato/Satin chrome



ZL SuperOro lucido/  
SuperGold bright



TS SuperOro satinato/  
SuperGold satin



NL SuperNichel lucido/  
SuperNickel bright



NS SuperNichel satinato/  
SuperNickel saten



IS SuperInox satinato/  
SuperStainlessSteel satin



RS SuperRame satinato/  
SuperCopper satin



DS SuperBronzo satinato/  
SuperBronze satin



US SuperAntracite satinato/  
SuperAnthracite satin

C178



K178











# special

maniglie con materiali  
o lavorazioni particolari  
door handles with particular  
materials or processes





# Edge Peter Marino 2008

Peter Marino, architetto conosciuto e apprezzato per il suo design anche dalle icone della moda, ha contribuito a ridefinire in chiave moderna il lusso in tutto il mondo. La maniglia per porta disegnata per Olivari forse è una chiara esemplificazione di questo concetto. Una struttura geometrica il cui bordo incornicia una striscia realizzata in diversi materiali, per diventare accessori che cambiano l'uso. Legno, vetro o Corian ciascuno conferisce un proprio stile alla maniglia

Peter Marino, designer and architect - his work is also appreciated and sought-after by fashion icons - reinterprets luxury on a global scale, redefining the everyday in contemporary terms. This door handle designed for Olivari is a clear example of this concept. A geometric structure whose borders frame an inset strip made of various materials, transforming it into an accessory that changes to suit its surroundings. Wood, glass or Corian each imparts its own stylistic flavor to the door handle.

M212



EB Cromo lucido-Inox satinato/  
Bright chrome-Satin stainlesssteel



6E Cromo lucido-Vetro opaco/  
Bright chrome-Mat glass



EC Cromo lucido-Ciliegio/  
Bright chrome-Cherry wood



MC Cromo satinato-Ciliegio/  
Satin chrome-Cherry wood



ZC SuperOro lucido-Ciliegio/  
SuperGold bright-Cherry wood



6M Cromo satinato-Vetro opaco/  
Satin chrome-Mat glass



EV Cromo lucido-Rovere/  
Bright chrome-Oak wood



MV Cromo satinato-Rovere/  
Satin chrome-Oak wood



ZV SuperOro lucido-Rovere/  
SuperGold bright-Oak wood



EA Cromo lucido-Corian bianco/  
Bright chrome-White Corian



EW Cromo lucido-Wengé/  
Bright chrome-Wengé



MW Cromo satinato-Wengé/  
Satin chrome-Wengé



ZW SuperOro lucido-Wengé/  
SuperGold bright-Wengé



MA Cromo satinato-Corian bianco/  
Satin chrome-White Corian







# Ice Cube Dominique Perrault 2010

Il modello Ice Cube si può dire sia la prima maniglia in cristallo molato, ossia ricavato da una lastra di cristallo tecnico e super-trasparente. In questo “gioco di volumi semplificati” tipici del linguaggio di Dominique Perrault – grazie anche alla collaborazione di Gaëlle Lauriot-Prévost – l’ispirazione nasce da uno strumento quale il morsetto usato naturalmente nei cantieri per tenere insieme forme e materiali diversi. Il punto di connessione tra il cristallo e il “dente” della sezione a L del mozzo in metallo è risolto con un incollaggio strutturale di precisione che ha richiesto una lunga sperimentazione. A volte la semplicità nasconde al suo interno grandi complessità. *Antonio Olivari*

In all probability, the Ice Cube model is the first door handle ever made in polished glass. It is obtained from a sheet of high-tech super-clear glass. As is typical to the visual language employed by Perrault, and thanks to his teamwork here with Lauriot-Prévost, we see a play of simplified volumes. Part of the inspiration came from the clamps used on construction sites to hold together different shapes and materials. The point of connection between the glass and the flap of the L-shaped metal shaft is resolved by means of structural adhesive. The attachment is so precise it required lengthy experimentation. Sometimes simple appearances conceal great complexity. *Antonio Olivari*

M223B



C6 Cromo lucido-trasparente/Bright chrome-transparent



M6 Cromo satinato-trasparente/Satin chrome-transparent

C223



K223B











# Crystal Diamond Marcel Wanders 2015

La collezione di maniglie Crystal del 2015 di Marcel Wanders è una sorta di compendio della storia e dell'abilità artigianale, maturata dall'azienda in oltre 100 anni di vita. È una luminosa e scintillante continuità della combinazione di minimalismo e classicismo evocati dalla sua maniglia "Dolce Vita" (2014). Divisa in due parti, una in ottone e l'altra, frontale, in cristallo, ci consente d'intravedere – attraverso il cristallo – il decoro riflesso sull'ottone.

The Crystal family of door handles is a sort of compendium of the history and craftsmanship that our company has developed over more than 100 years. It is a luminous and sparkling continuation of the combined minimalist-classicistic personality of Wanders' Dolce Vita model from 2014. Divided in a brass base and a glass front, the transparency of the glass allows us to look through it and see the reflected decoration on the brass underneath.

M246B



C6 Cromo lucido/Bright chrome



Z6 SuperOro lucido/  
SuperGold bright



M6 Cromo satinato/Satin chrome



U6 SuperAntracite satinato/  
SuperAnthracite satin

C246



K246B







# Crystal Royal Marcel Wanders 2015

La collezione di maniglie Crystal è frutto dell'estro immaginifico di Marcel Wanders e della sua passione per il cristallo che lo aveva già portato a collaborare con Baccarat. Da questa sua esperienza deriva la scelta di scomporre l'impugnatura scultorea in due parti: una strutturale in ottone, l'altra decorativa in cristallo trasparente. Il decoro Royal gioca sul piacere visivo della moltiplicazione dei riflessi di luce, e sulla sorpresa dell'afferrare una forma sfaccettata come una gemma preziosa. *Antonio Olivari*

The Crystal family of door handles is the fruit of Wanders' imaginative flair and his love of crystal, which he has explored by working with Baccarat. That experience inspired him to divide the sculptural handgrip into two parts. One is structural, made in brass; the other is ornamental, made in clear crystal. The Royal's decoration plays with the optical effect of multiplying reflections of light, and offers the pleasant surprise of grasping a form that is faceted like a precious gem. *Antonio Olivari*

M245B



C6 Cromo lucido/Bright chrome



Z6 SuperOro lucido/  
SuperGold bright



M6 Cromo satinato/Satin chrome



U6 SuperAntracite satinato/  
SuperAnthraccite satin

C245

K245B









# Aurora Alessandro Mendini 1994

L'idea di una maniglia che racchiudesse la magia del vetro è nata dal colloquio con Alessandro Mendini. Ebbe subito l'intuizione di una goccia di vetro trasparente integrata o emergente dal metallo, e così anche l'idea della forma. Poi la palla è passata a noi. Non avevamo mai affrontato il tema dell'unione del nostro abituale metallo con il vetro, a noi sconosciuto. Non è stato quindi facile entrare in sintonia con gli artigiani di Murano e indurli a lavorare con una precisione a cui non erano abituati. Il risultato però è stato di grande soddisfazione per tutti e ha portato con sé un caleidoscopio di soluzioni estetiche mai sperimentate prima.

*Antonio Olivari*

The idea for a door handle containing the magic of glass originated in a conversation with Alessandro Mendini. He wanted to design a drop-shaped piece of glass integrated with or emerging from metal. Then the ball was in our court. We had never thought of uniting our habitual material of metal with glass, because we had no experience with it. So it was not simple to enter into harmony with the artisans of Murano in Venice and have them craft the glass with a degree of precision they were not used to. But the result was of great satisfaction to everyone, and along with it came a kaleidoscope of aesthetic solutions we had not seen before.

*Antonio Olivari*

## M164

Cromo lucido/Bright chrome



**C1** azzurro/light blue



**C6** trasparente/transparent

Cromo satinato/Satin chrome



**6M** trasparente/transparent



**C5** ambra/amber

## C164

## K164



disponibile anche/also available:  
**SuperOro lucido/SuperGold bright**

disponibile anche in combinazioni personalizzate:  
finitura lucida + vetro opaco oppure  
cromo satinato + vetro trasparente/  
also available in custom combinations:  
bright finish + mat glass or  
satin chrome + transparent glass





# Chelsea Jean Nouvel 2013

La ricerca condotta per mettere a punto il modello Chelsea è espressione della sensibilità artistica di Jean Nouvel. La maniglia nasce in contemporanea con la torre residenziale "100 11th Avenue" che Jean progetta per il quartiere nel cuore di Manhattan da cui prende il nome: egli immagina un'architettura come una "macchina per la visione" in grado di catturare i riflessi del fiume Hudson sul quale si affaccia. Per le maniglie, Jean ci chiede un modello fuori dall'usuale. È alla ricerca di una forma diversa rispetto alla geometria tubolare che convenzionalmente ispira la leva. Rifiuta in partenza anche un materiale come l'acciaio, perché vuole che siano i sensi a guidare la sua definizione formale. Ci spiega che vuole siano stimolati da una forma morbida, sensuale, piacevole al tatto e da un materiale caldo, quasi soffice. Vuole infine che diventi un segno grazie al colore. La maniglia nasce con queste premesse: è modellata sull'impronta della mano che l'afferra, ed è realizzata in gomma morbida e nera. In fabbrica poi, per la produzione di serie, sperimentiamo insieme differenti materiali, dal legno al vetro, fino a individuare la porcellana, declinata nelle versioni nero opaco e bianco lucido: entrambe icastiche, di grande impatto comunicativo. *Antonio Olivari*

The studies conducted to fine-tune the Chelsea handle are an expression of Jean Nouvel's artistic sensibility. He designed it when he was working on 100 Eleventh Avenue in the Chelsea neighbourhood of Manhattan, a 23-storey residential tower he describes as "a vision machine" that captures reflections from the nearby Hudson River. For the handles, Nouvel asked us for an unusual model. He wanted a shape that was different from the tubular geometry conventionally used for the lever. He also refused the materiality of steel, because he was letting his senses guide its formal definition. He wanted them to be stimulated by a soft, sensual shape that was pleasant to the touch, and a material that was warm, almost buttery. And finally, his aim was for the handle to be a mark, thanks to the use of colour. These were the requirements that engendered the Chelsea. It is modelled after the print of a hand gripping it, and made in soft, black rubber. In the factory, when we engineered it for serial production, we experimented with Nouvel using different materials like wood and glass, until we decided to use porcelain in matte black and shiny white. Both are lively objects with great communicative impact. *Antonio Olivari*

M232B



CB Cromo lucido/bianco  
Bright chrome/white



MB Cromo satinato/bianco  
Satin chrome/white



CE Cromo lucido/nero opaco  
Bright chrome/mat black



ME Cromo satinato/nero opaco  
Satin chrome/mat black

C232



K232B



- 1\_ Fondation Cartier, Paris, France 1994
- 2\_ Institut du monde arabe IMA, Paris 1987
- 3\_ Conference Center, France, 1993
- 4\_ 100 11th Avenue, New York 2010



1



2



3



4







# Club

Vico Magistretti 1999

Come succedeva sempre con Vico, l'idea è nata da una conversazione: ragionando con lui sul senso del comfort è nata l'idea di realizzare una maniglia con un rivestimento in pelle per renderla piacevole al tatto. Vico ha pensato in una logica di tipo "industriale" disegnando due gusci assottigliati su cui incollare lo strato di pelle in modo da dare continuità alla forma ed eliminare la cucitura: la parte tipicamente più soggetta a sporcarsi e a usurarsi. La proposta mi è parsa subito molto interessante e innovativa: da sviluppare. *Antonio Olivari*

As always seemed to happen with Vico, inspiration for Club was born during conversation. Talking with him about the feeling of comfort, he came up with the idea of a leather-clad handle that would be pleasant to touch. Along the lines of industrial logic, he designed two tapered half-shells to which the leather was glued. This gave continuity to the form and allowed us to avoid the sewn seam, which would have trapped dirt and been susceptible to wear and tear. I immediately found the proposal very interesting and innovative, so we developed it. *Antonio Olivari*

M181

Cromo lucido/Bright chrome



XB avorio/ivory



XF testa di moro/dark brown



XE marrone/brown



XN nero/black

C181

K181



disponibile anche/also available  
SuperNichel satinato/SuperNickel satin







## Boma Ny Monti G.P.A. 1972

Gli architetti Gianemilio Monti, Pietro Monti e Anna Bertarini, persone di grande professionalità e gentilezza, avevano affascinato papà con l'idea di realizzare la prima maniglia in plastica prodotta in Italia. Certamente Boma si è rivelata la più diffusa e apprezzata. Nostro padre ci teneva particolarmente a specificare che era stata utilizzata la resina Durethan della Bayer di Leverkusen, sia perché si trattava di un ottimo materiale plastico, sia perché i tecnici della Bayer si dimostrarono molto disponibili e prodighi di consigli. Per un'azienda come Olivari, da sempre abituata a realizzare in metallo le sue maniglie, la plastica sembrava un azzardo: il mercato l'avrebbe capita e accettata? Fu una scommessa e fu vinta. Oltre a essere stato un ottimo biglietto da visita per il mondo del design, anno dopo anno la Boma è diventata un *best-seller*. La novità della forma e il colore, uniti all'economicità del materiale e del processo di produzione, hanno determinato un successo durevole: come tale resiste nel tempo. *Antonio Olivari*

The architects Gianemilio Monti, Pietro Monti and Anna Bertarini, highly professional and kind people, intrigued our father with their proposal to make the first plastic handle produced in Italy. Of course Boma turned out to be the most widely used and appreciated. Dad was always particularly keen on specifying that they were made using Durethan resin by the Bayer company from Leverkusen, Germany. He liked to mention that for two reasons. One is that the plastic was an excellent material, and the other was because the technicians at Bayer were so forthcoming and generous with advice. For a company like Olivari, used to making its handles in metal, plastic had seemed risky. Would the market appreciate it? It was a wager, and it was won. Besides being a good calling card in the design world, year after year the Boma was a best-seller. The novelty of shape and colour combined with the inexpensiveness of the material and production process made for long-lasting success, and this has continued to be so over time. *Antonio Olivari*

M501



NE Nero/Black



GR Grigio/Grey



BI Bianco/White

C501



K501



1\_Casa d'abitazione in via Calco 2 (con/  
with Enrico Freyrie), Milano 1954-1956  
2\_Casa d'abitazione in via A. Moro  
a San Donato Milanese - 1991  
3\_Appendiabiti in compensato  
multistrato, de Padova ICF 1955





# Iseo Ny Sergio Asti 1983

M507



NE Nero/Black



BI Bianco/White

C507



K507





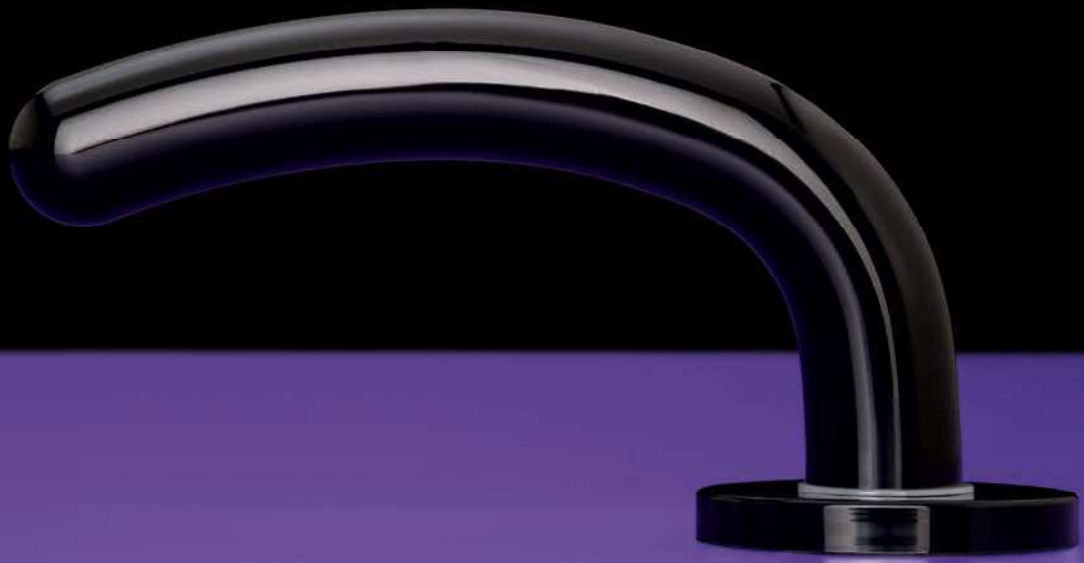



# Chiara Ny Studio Olivari 1975

M509



NE Nero/Black



BI Bianco/White

C509



K509





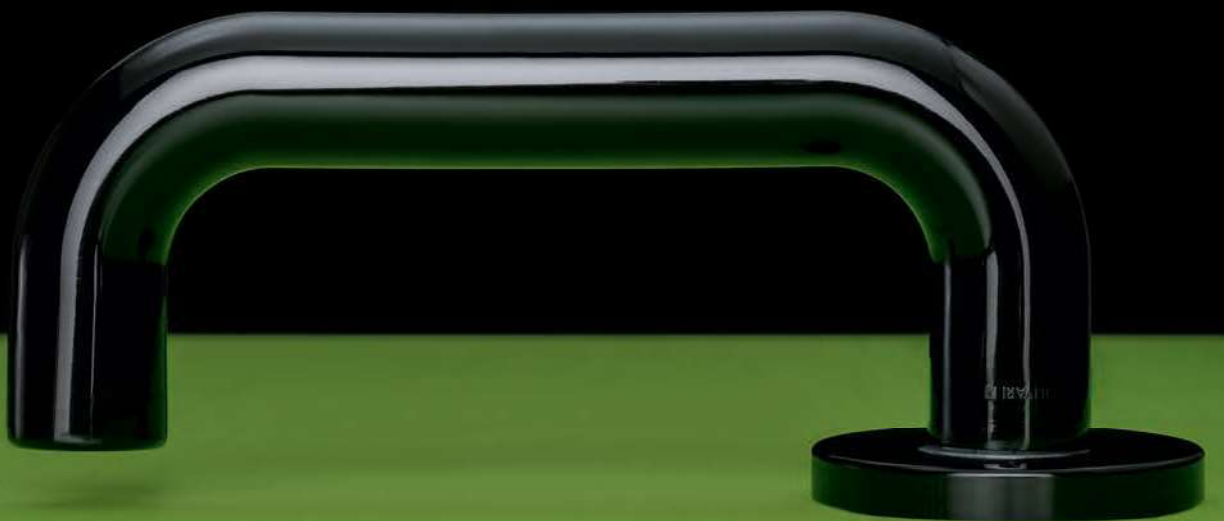





# guilloché

Il guilloché è una tecnica decorativa di incisione realizzata con apposite macchine che, guidate manualmente, generano un preciso, intricato e ripetitivo pattern sul materiale di base. A differenza dell'incisione *tout court*, realizzata a mano, che si presta a un decoro più libero e naturalistico, quella realizzata con le macchine à guillocher è tipicamente meccanica e ripetitiva, consente però di ottenere un'infinità di pattern differenti al variare dei parametri di lavorazione combinandosi alla sensibilità tecnica, ma anche estetica, dell'operatore. L'origine esatta delle prime macchine non è nota con certezza. È possibile che abbiano paternità svizzera, forse per opera di un ingegnere francese di nome Guillot. I primi esempi di casse di orologio lavorate con questa tecnica portano inciso l'anno 1624. L'effettiva introduzione nel settore dell'orologeria risale al 1786, quando Abraham-Louis Breguet inizia a utilizzarla per decorare i quadranti e le casse dei suoi orologi. Questa tecnica sperimenta una straordinaria popolarità nel XIX secolo, grazie soprattutto all'opera di Peter Carl Fabergé.

Guilloche is a decorative engraving technique that uses special lathes. Guided manually, these machines draw a precise, intricate, repeated pattern on the metal surface. Different to freehand engraving, which is suited to more naturalistic and free decorations, guilloche engraving is typically mechanical and reiterative. It allows for infinite different patterns by varying the parameters of the process, which work in concert with the technician's technical sensibility and aesthetic judgement. The exact origin of the first guilloche machines is uncertain, but perhaps they were Swiss or invented by a French engineer named Guillot. The first examples of its use are found on watch cases engraved with the year 1624. The definitive introduction of guilloche in watchmaking dates back to 1786, when Abraham-Louis Breguet began using it to decorate the dials and cases of his watches. In the 19<sup>th</sup> century, the technique became highly popular, largely thanks to the work of Peter Carl Fabergé.

# Diana Barley Studio Olivari 2016

M1DBB



CR Cromo lucido/Bright chrome



NL SuperNichel lucido/  
SuperNickel bright



ZL SuperOro lucido/  
SuperGold bright

C1DB



K1DBB



**Barley “a chicco d’orzo”, allure brillante e sofisticata.**

La decorazione Barley riprende il classico motivo “a chicco d’orzo” della tradizione guilloché: la trama di fitte incisioni che si rincorrono conferisce alla maniglia un’allure brillante e sofisticata.

**Engraving similar to grains of barley with a shiny sophisticated allure.**

The Barley decoration is based on the classic grain motif of traditional guilloché engraving. The running, close-set pattern gives the handle shiny, sophisticated allure.

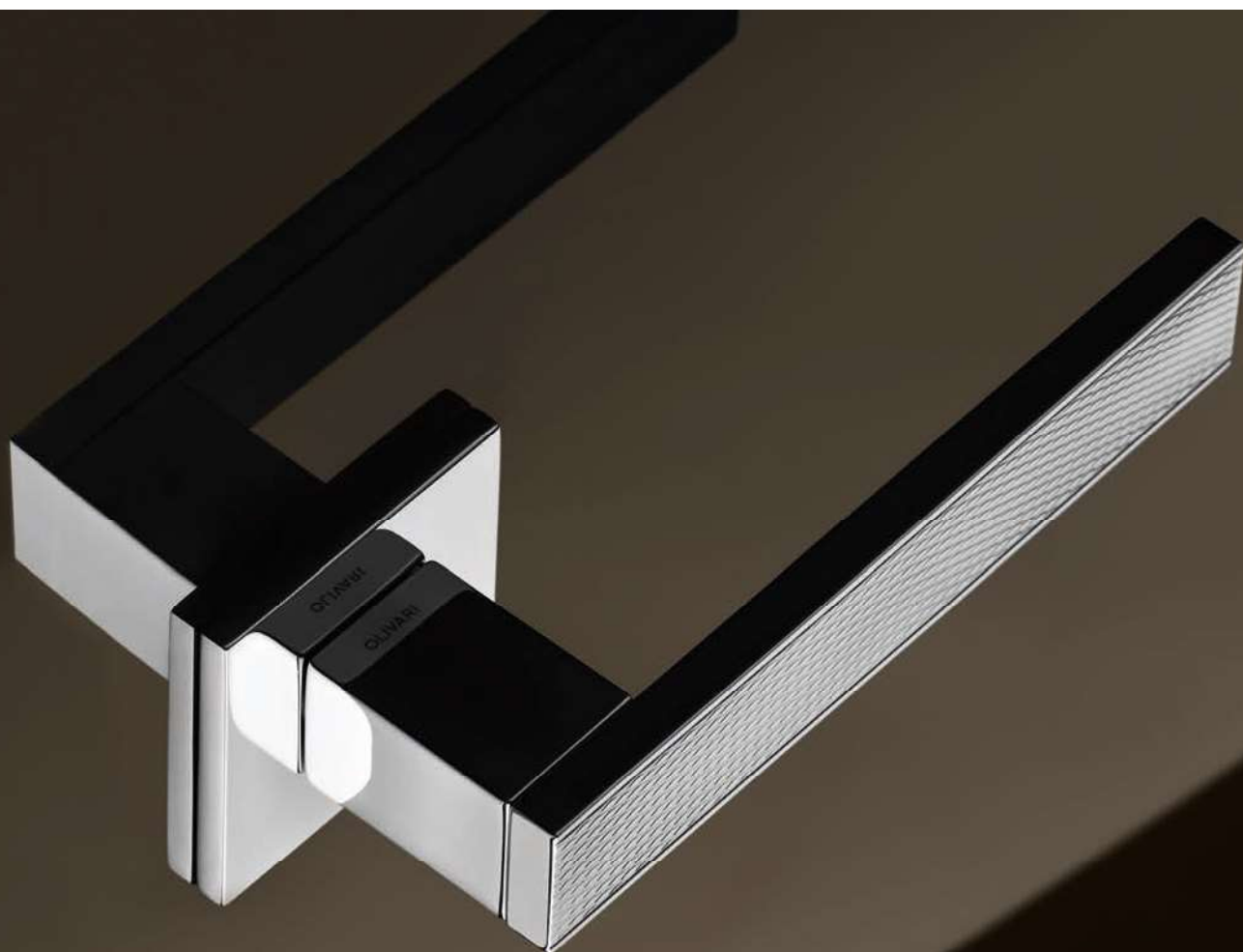







# Diana Damier Studio Olivari 2016

M1DDB



CR Cromo lucido/Bright chrome



NL SuperNichel lucido/  
SuperNickel bright



ZL SuperOro lucido/  
SuperGold bright

C1DD



K1DDB



**Damier "a scacchi", caratteri di un'eleganza sofisticata.**  
La decorazione Damier riprende il classico motivo "a scacchi" della tradizione guilloché: la trama di fitte incisioni alternate esprime i caratteri di un'eleganza sofisticata.

**Elegant chequers with a sophisticated air.**  
The Damier decoration takes up the classic chequerboard motif of traditional guilloché engraving with alternating squares of close-set patterns of sophisticated elegance.







# Diana Chevron

Studio Olivari 2016

M1DCB



CR Cromo lucido/Bright chrome



NL SuperNichel lucido/  
SuperNickel bright



ZL SuperOro lucido/  
SuperGold bright

C1DC



K1DCB



**Chevron “a zig-zag” o “spina di pesce”, espressione di preziosità e raffinatezza.**

La decorazione Chevron riprende il classico motivo “a zig-zag”, o a “spina di pesce”, della tradizione guilloché, espressione di preziosità e raffinatezza.

**A herringbone motif expressing precious refinement.**

The Chevron decoration takes up the classic herringbone motif of traditional guilloché engraving as an expression of preciousness and refinement.

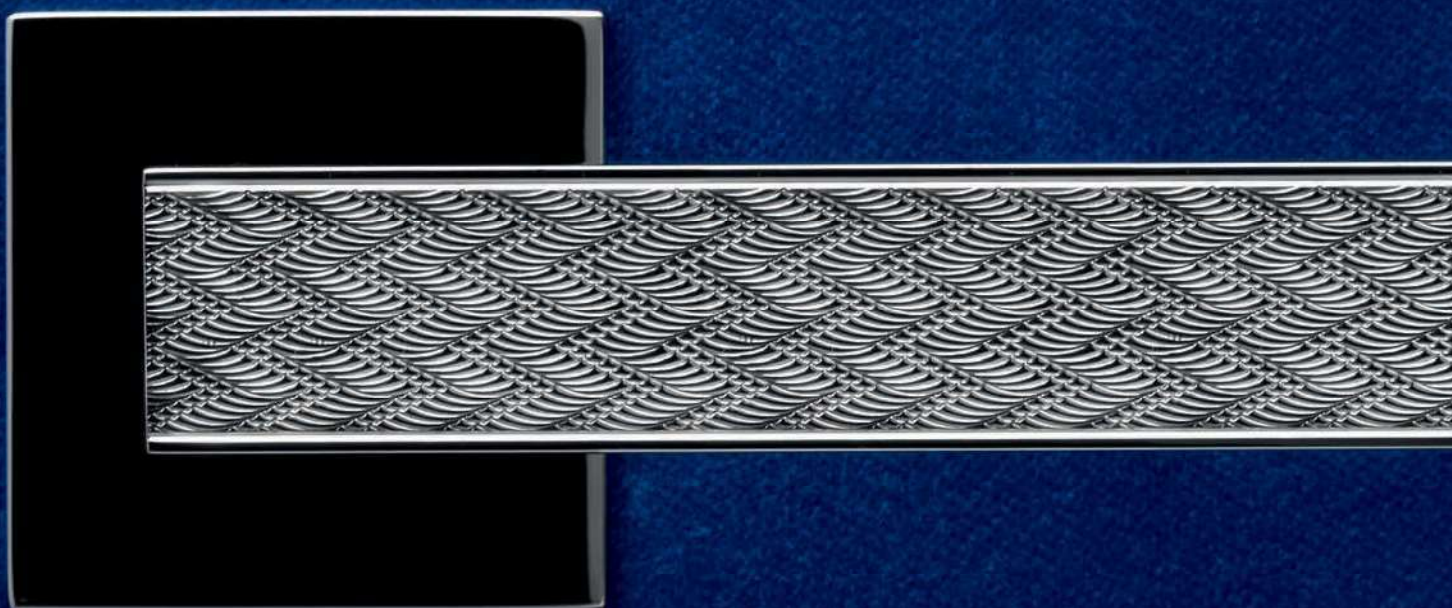



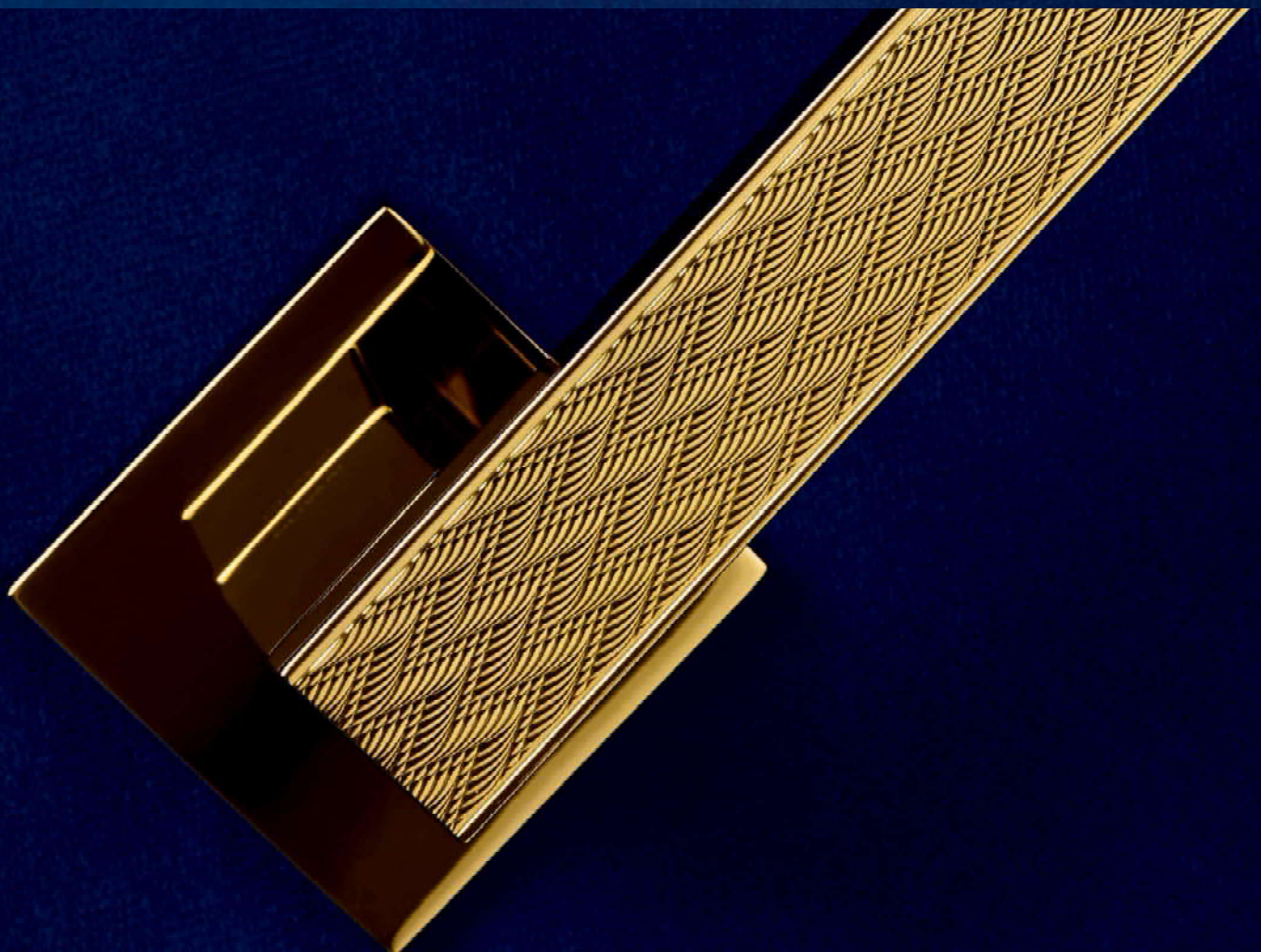

# Atena Ligne Studio Olivari 2016

M1ALB



CR Cromo lucido/Bright chrome



NL SuperNichel lucido/  
SuperNickel bright



ZL SuperOro lucido/  
SuperGold bright

C1AL



K1ALB



**Ligne “a righe”, eleganza essenziale e senza tempo.**

La decorazione Ligne sposa il classico motivo “a righe” della tradizione guilloché con la perfetta geometria cilindrica della maniglia per una soluzione di eleganza essenziale e senza tempo.

**An elegant linear pattern, timeless and understated.**

The Ligne decoration marries the classic lined motif of traditional guilloché engraving with the perfect cylindrical geometry of the handle, resulting in understated, timeless elegance.









# Atena Rank Studio Olivari 2016

M1ARB



CR Cromo lucido/Bright chrome



NL SuperNichel lucido/  
SuperNickel bright



ZL SuperOro lucido/  
SuperGold bright

C1AR



K1ARB



**Rank "a onda", riflessi di forte carattere.**

La decorazione Rank riprende il classico motivo "a onda" della tradizione guilloché che ben si sposa con la purezza geometrica del cilindro creando riflessi di forte carattere.

**Wavy zigzags for characterful reflections.**

The Rank decoration takes up the classic wavy zigzag motif of traditional guilloché engraving, which lends itself perfectly to the geometrical pureness of the cylinder, creating characterful reflections.







# Atena Panier Studio Olivari 2016

M1APB



CR Cromo lucido/Bright chrome



NL SuperNichel lucido/  
SuperNickel bright



ZL SuperOro lucido/  
SuperGold bright

C1AP



K1APB



**Panier , intreccio di vimini delle ceste, eleganza e classicità.**

La decorazione Panier riprende il classico motivo della tradizione guilloché che allude all'intreccio di vimini delle ceste, esprimendo eleganza e classicità.

**A basket-weave pattern with classic elegance.**

The Panier decoration takes up the classic basket-weave motif of traditional guilloché engraving to express elegance and classicism.











placca

plate



# Placca orizzontale bassa

## Low horizontal plate

Adatta per tutte le maniglie  
Suitable for all catalogue handles

La placca orizzontale bassa è stata ideata come alternativa alla rosetta, per svolgere una duplice funzione.

Innanzitutto una funzione estetica:

essendo una sorta di sfondo, di proiezione della maniglia, rende l'insieme un tutt'uno integrato, con forte segnalazione e connotazione.

In secondo luogo una funzione tecnica:

la sua estensione dietro la maniglia impedisce di toccare la porta e quindi evita il rischio di urtarla e rovinarla.

Per consentire di utilizzare la placca orizzontale con tutte le maniglie del catalogo, sono state realizzate due versioni: una rettangolare e una ovale. Entrambe sono dotate di molla di ritorno molto robusta e di posizione di arresto orizzontale, al fine di riportare sempre in corretta posizione la maniglia dopo il suo utilizzo. Testate secondo la prova di resistenza (norma DIN EN 1906), hanno superato i 200.000 cicli, risultando appartenere alla classe 4, cioè adatte agli utilizzi gravosi. Di fatto poi la prova è stata prolungata fino a 1.000.000 di cicli, che sono stati agevolmente superati.

The low horizontal plate was designed as an alternative to the rosette, to perform a dual function.

First of all, an aesthetic function:

being a sort of backdrop, an extension of the door handle, it creates the effect of one whole integrated piece, with strong expression and substance.

Secondly, a technical function:

its presence prevents the door handle from touching the door and therefore avoids the risk of hitting and damaging it.

To allow the use of the horizontal plate with all the door handles in the catalogue, two versions have been made: a rectangular and an oval version. Both are equipped with a very strong return spring and a horizontal stop position, in order to always return the door handle to its correct position after use. Tested according to the resistance test (DIN EN 1906), they exceeded 200,000 cycles, resulting in grade 4 classification, that is suitable for heavy use. In fact, the test was extended up to 1,000,000 cycles, which was easily exceeded.



CR Cromo lucido/Bright chrome



ZL SuperOro lucido/  
SuperGold bright



NL SuperNichel lucido/  
SuperNickel bright



RS SuperRame satinato/  
SuperCopper satin



CO Cromo satinato/Satin chrome



TS SuperOro satinato/  
SuperGold satin



NS SuperNichel satinato/  
SuperNickel satin



DS SuperBronzo satinato/  
SuperBronze satin



IS SuperInox satinato/  
SuperStainlessSteel satin



US SuperAntracite satinato/  
SuperAnthracite satin

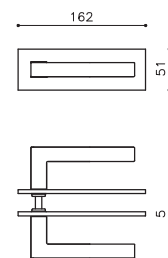

CR Cromo lucido/Bright chrome



ZL SuperOro lucido/  
SuperGold bright



NL SuperNichel lucido/  
SuperNickel bright



RS SuperRame satinato/  
SuperCopper satin



CO Cromo satinato/Satin chrome



TS SuperOro satinato/  
SuperGold satin



NS SuperNichel satinato/  
SuperNickel satin



DS SuperBronzo satinato/  
SuperBronze satin



IS SuperInox satinato/  
SuperStainlessSteel satin



US SuperAntracite satinato/  
SuperAnthracite satin

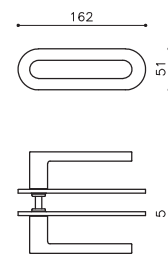









pomoli zancati  
pomoli centrali

offset door knobs  
central door knobs

Pomoli zancati

## Planet Q Studio Olivari



ottone/brass

CR Cromo lucido/Bright chrome  
CO Cromo satinato/Satin chrome  
IS SuperInox satinato/  
SuperStainlessSteel satin

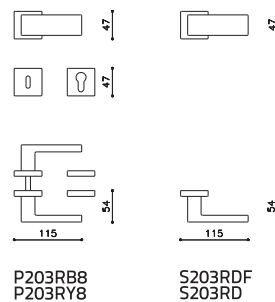

## Planet Studio Olivari



ottone/brass

CR Cromo lucido/Bright chrome  
CO Cromo satinato/Satin chrome  
NS SuperNichel satinato/  
SuperNickel satin  
IS SuperInox satinato/  
SuperStainlessSteel satin

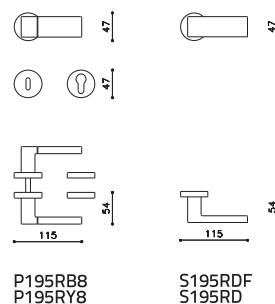

## Blindo Studio Olivari



ottone/brass

CR Cromo lucido/Bright chrome  
CO Cromo satinato/Satin chrome  
ZL SuperOro lucido/SuperGold bright  
TS SuperOro satinato/SuperGold satin  
NL SuperNichel lucido/  
SuperNickel bright  
NS SuperNichel satinato/  
SuperNickel satin  
IS SuperInox satinato/  
SuperStainlessSteel satin  
RS SuperRame satinato/  
SuperCopper satin  
DS SuperBronzo satinato/  
SuperBronze satin  
US SuperAntracite satinato/  
SuperAnthracite satin

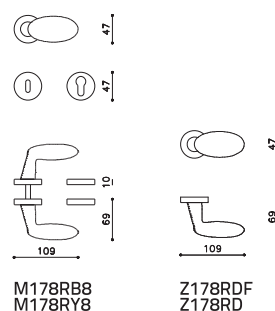

## Uovo Studio Olivari



ottone/brass

CR Cromo lucido/Bright chrome  
CO Cromo satinato/Satin chrome  
NP Nero opaco/Mat black  
ZL SuperOro lucido/SuperGold bright  
TS SuperOro satinato/SuperGold satin  
DS SuperBronzo satinato/  
SuperBronze satin

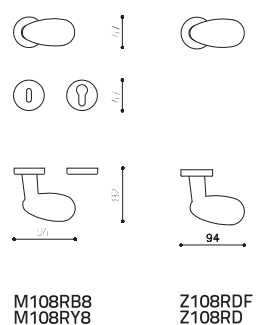

## Bond Andrea Branzi



ottone/brass

CO Cromo satinato/Satin chrome  
ZL SuperOro lucido/SuperGold bright

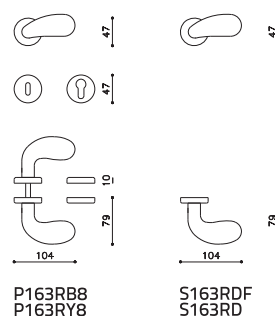



# Diana Studio Olivari



**ottone/brass**

- CR Cromo lucido/Bright chrome
- CO Cromo satinato/Satin chrome
- ZL SuperOro lucido/SuperGold bright
- NL SuperNichel lucido/SuperNickel bright
- IS SuperInox satinato/SuperStainlessSteel satin
- RS SuperRame satinato/SuperCopper satin
- DS SuperBronzo satinato/SuperBronze satin
- US SuperAntracite satinato/SuperAnthracite satin

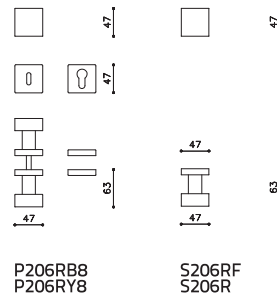

**ottone/brass**

- CR Cromo lucido/Bright chrome
- CO Cromo satinato/Satin chrome
- ZL SuperOro lucido/SuperGold bright
- NL SuperNichel lucido/SuperNickel bright
- IS SuperInox satinato/SuperStainlessSteel satin
- RS SuperRame satinato/SuperCopper satin
- DS SuperBronzo satinato/SuperBronze satin
- US SuperAntracite satinato/SuperAnthracite satin

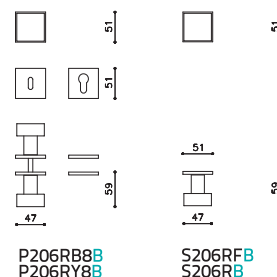

# Link Piero Lissoni



**ottone/brass**

- CR Cromo lucido/Bright chrome
- CO Cromo satinato/Satin chrome
- ZL SuperOro lucido/SuperGold bright
- NL SuperNichel lucido/SuperNickel bright
- NS SuperNichel satinato/SuperNickel satin
- IS SuperInox satinato/SuperStainlessSteel satin
- RS SuperRame satinato/SuperCopper satin
- DS SuperBronzo satinato/SuperBronze satin
- US SuperAntracite satinato/SuperAnthracite satin

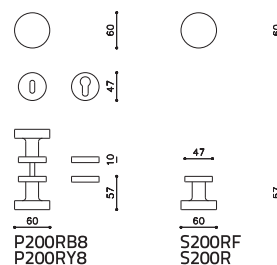

**ottone/brass**

- CR Cromo lucido/Bright chrome
- CO Cromo satinato/Satin chrome
- ZL SuperOro lucido/SuperGold bright
- NL SuperNichel lucido/SuperNickel bright
- NS SuperNichel satinato/SuperNickel satin
- IS SuperInox satinato/SuperStainlessSteel satin
- RS SuperRame satinato/SuperCopper satin
- DS SuperBronzo satinato/SuperBronze satin
- US SuperAntracite satinato/SuperAnthracite satin

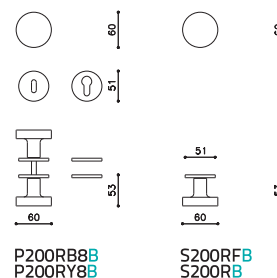

# Oscar Studio Olivari



**ottone/brass**

- CR Cromo lucido/Bright chrome
- CO Cromo satinato/Satin chrome
- NL SuperNichel lucido/  
SuperNickel bright
- RS SuperRame satinato/  
SuperCopper satin
- DS SuperBronzo satinato/  
SuperBronze satin

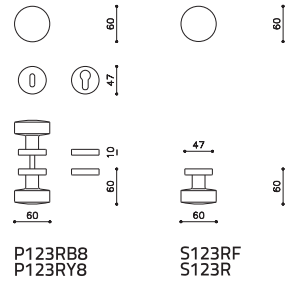

P123RB8  
P123RY8

S123RF  
S123R

# Roger Studio Olivari



**ottone/brass**

- CR Cromo lucido/Bright chrome
- CO Cromo satinato/Satin chrome
- TS SuperOro satinato/SuperGold satin
- NL SuperNichel lucido/  
SuperNickel bright
- RS SuperRame satinato/  
SuperCopper satin
- DS SuperBronzo satinato/  
SuperBronze satin

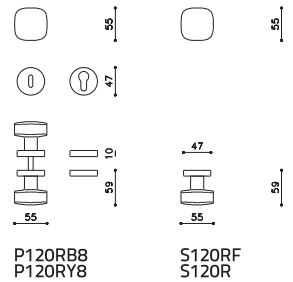

P120RB8  
P120RY8

S120RF  
S120R



## Edison ø 60 Mazza, Gramigna



**ottone/brass**

- CR Cromo lucido/Bright chrome
- CO Cromo satinato/Satin chrome
- ZL SuperOro lucido/SuperGold bright
- TS SuperOro satinato/SuperGold satin
- NL SuperNichel lucido/SuperNickel bright
- IS SuperInox satinato/SuperStainlessSteel satin
- RS SuperRame satinato/SuperCopper satin
- DS SuperBronzo satinato/SuperBronze satin
- US SuperAntracite satinato/SuperAnthracite satin

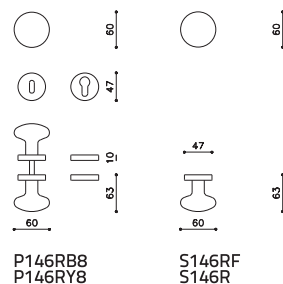

## Edison ø 70 Mazza, Gramigna



**ottone/brass**

- CR Cromo lucido/Bright chrome
- CO Cromo satinato/Satin chrome
- ZL SuperOro lucido/SuperGold bright
- TS SuperOro satinato/SuperGold satin
- NL SuperNichel lucido/SuperNickel bright
- IS SuperInox satinato/SuperStainlessSteel satin
- RS SuperRame satinato/SuperCopper satin
- DS SuperBronzo satinato/SuperBronze satin
- US SuperAntracite satinato/SuperAnthracite satin

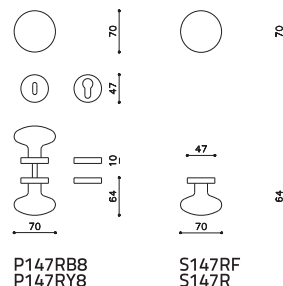

## Edison ø 80 Mazza, Gramigna



**ottone/brass**

- CR Cromo lucido/Bright chrome
- CO Cromo satinato/Satin chrome

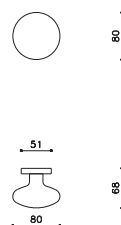





# chiavistelli

latches

# Cubo Studio Olivari



**ottone/brass**

- CR Cromo lucido/Bright chrome
- CO Cromo satinato/Satin chrome
- ZL SuperOro lucido/SuperGold bright
- NL SuperNichel lucido/SuperNickel bright
- NS SuperNichel satinato/SuperNickel satin
- IS SuperInox satinato/SuperStainlessSteel satin
- RS SuperRame satinato/SuperCopper satin
- DS SuperBronzo satinato/SuperBronze satin
- US SuperAntracite satinato/SuperAnthracite satin

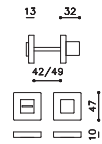

H136V6

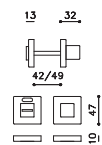

H136VF6

# Space Q Studio Olivari



**ottone/brass**

- CR Cromo lucido/Bright chrome
- CO Cromo satinato/Satin chrome
- ZL SuperOro lucido/SuperGold bright
- NL SuperNichel lucido/SuperNickel bright
- NS SuperNichel satinato/SuperNickel satin
- IS SuperInox satinato/SuperStainlessSteel satin
- RS SuperRame satinato/SuperCopper satin
- DS SuperBronzo satinato/SuperBronze satin
- US SuperAntracite satinato/SuperAnthracite satin

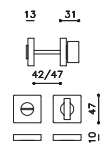

H202V6

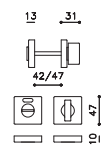

H202VF6



Verona Q Studio Olivari



ottone/brass

- CR Cromo lucido/Bright chrome
- CO Cromo satinato/Satin chrome
- ZL SuperOro lucido/SuperGold bright
- NL SuperNichel lucido/SuperNickel bright
- NS SuperNichel satinato/SuperNickel satin
- IS SuperInox satinato/SuperStainlessSteel satin
- RS SuperRame satinato/SuperCopper satin
- DS SuperBronzo satinato/SuperBronze satin
- US SuperAntracite satinato/SuperAnthracite satin

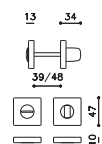

H117V6

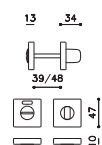

H118V6

# Link Piero Lissoni



**ottone/brass**

- CR Cromo lucido/Bright chrome
- CO Cromo satinato/Satin chrome
- ZL SuperOro lucido/SuperGold bright
- TS SuperOro satinato/SuperGold satin
- NL SuperNichel lucido/SuperNickel bright
- NS SuperNichel satinato/SuperNickel satin
- IS SuperInox satinato/  
SuperStainlessSteel satin
- RS SuperRame satinato/  
SuperCopper satin
- DS SuperBronzo satinato/  
SuperBronze satin
- US SuperAntracite satinato/  
SuperAnthracite satin

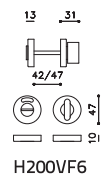
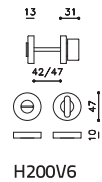

# Space Studio Olivari



**ottone/brass**

- CR Cromo lucido/Bright chrome
- CO Cromo satinato/Satin chrome
- ZL SuperOro lucido/SuperGold bright
- NL SuperNichel lucido/SuperNickel bright
- NS SuperNichel satinato/SuperNickel satin
- IS SuperInox satinato/  
SuperStainlessSteel satin
- RS SuperRame satinato/  
SuperCopper satin
- DS SuperBronzo satinato/  
SuperBronze satin
- US SuperAntracite satinato/  
SuperAnthracite satin

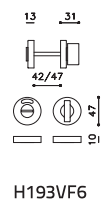
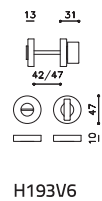



Verona V Studio Olivari



ottone/brass

- CR Cromo lucido/Bright chrome
- CO Cromo satinato/Satin chrome
- NP Nero opaco/Mat black
- ZL SuperOro lucido/SuperGold bright
- TS SuperOro satinato/SuperGold satin
- NL SuperNichel lucido/SuperNickel bright
- NS SuperNichel satinato/SuperNickel satin
- IS SuperInox satinato/  
SuperStainlessSteel satin
- RS SuperRame satinato/  
SuperCopper satin
- DS SuperBronzo satinato/  
SuperBronze satin
- US SuperAntracite satinato/  
SuperAnthracite satin

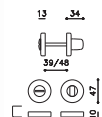

H106V6

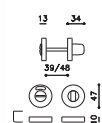

H109V6

Verona R Studio Olivari



ottone/brass

- CR Cromo lucido/Bright chrome
- CO Cromo satinato/Satin chrome
- ZL SuperOro lucido/SuperGold bright
- TS SuperOro satinato/SuperGold satin
- NL SuperNichel lucido/SuperNickel bright
- NS SuperNichel satinato/SuperNickel satin
- IS SuperInox satinato/  
SuperStainlessSteel satin
- RS SuperRame satinato/  
SuperCopper satin
- DS SuperBronzo satinato/  
SuperBronze satin

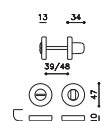

H107R6

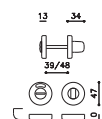

H108R6

# Alexandra F.A. Porsche



ottone/brass

CR Cromo lucido/Bright chrome  
CO Cromo satinato/Satin chrome  
IS SuperInox satinato/  
SuperStainlesssteel satin

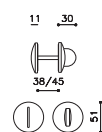

H150/6

---

# Icaro Paolo Portoghesi



ottone/brass

ZL SuperOro lucido/SuperGold bright

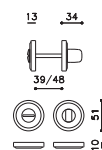

H168R6



Cubo Studio Olivari



ottone/brass

- CR Cromo lucido/Bright chrome
- CO Cromo satinato/Satin chrome
- ZL SuperOro lucido/SuperGold bright
- NL SuperNichel lucido/SuperNickel bright
- NS SuperNichel satinato/SuperNickel satin
- IS SuperInox satinato/SuperStainlessSteel satin
- RS SuperRame satinato/SuperCopper satin
- DS SuperBronzo satinato/SuperBronze satin
- US SuperAntracite satinato/SuperAnthracite satin

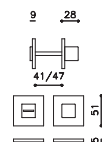

H136V6B

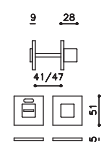

H136VF6B

Link Q Piero Lissoni



ottone/brass

- CR Cromo lucido/Bright chrome
- CO Cromo satinato/Satin chrome
- ZL SuperOro lucido/SuperGold bright
- TS SuperOro satinato/SuperGold satin
- NL SuperNichel lucido/SuperNickel bright
- NS SuperNichel satinato/SuperNickel satin
- IS SuperInox satinato/SuperStainlessSteel satin
- RS SuperRame satinato/SuperCopper satin
- DS SuperBronzo satinato/SuperBronze satin
- US SuperAntracite satinato/SuperAnthracite satin

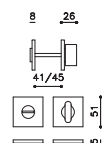

H209V6B

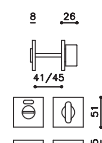

H209VF6B

# Space Q Studio Olivari



**ottone/brass**

- CR Cromo lucido/Bright chrome
- CO Cromo satinato/Satin chrome
- ZL SuperOro lucido/SuperGold bright
- TS SuperOro satinato/SuperGold satin
- NL SuperNichel lucido/SuperNickel bright
- NS SuperNichel satinato/SuperNickel satin
- IS SuperInox satinato/  
SuperStainlessSteel satin
- RS SuperRame satinato/  
SuperCopper satin
- DS SuperBronzo satinato/  
SuperBronze satin
- US SuperAntracite satinato/  
SuperAnthracite satin

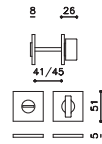

H202V6B

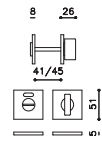

H202VF6B

# Verona Q Studio Olivari



**ottone/brass**

- CR Cromo lucido/Bright chrome
- CO Cromo satinato/Satin chrome
- ZL SuperOro lucido/SuperGold bright
- TS SuperOro satinato/SuperGold satin
- NL SuperNichel lucido/SuperNickel bright
- NS SuperNichel satinato/SuperNickel satin
- IS SuperInox satinato/  
SuperStainlessSteel satin
- RS SuperRame satinato/  
SuperCopper satin
- DS SuperBronzo satinato/  
SuperBronze satin
- US SuperAntracite satinato/  
SuperAnthracite satin

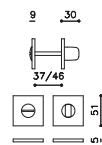

H117V6B

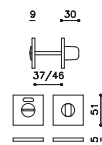

H117VF6B



Link Piero Lissoni



ottone/brass

- CR Cromo lucido/Bright chrome
- CO Cromo satinato/Satin chrome
- ZL SuperOro lucido/SuperGold bright
- TS SuperOro satinato/SuperGold satin
- NL SuperNichel lucido/SuperNickel bright
- NS SuperNichel satinato/SuperNickel satin
- IS SuperInox satinato/  
SuperStainlessSteel satin
- RS SuperRame satinato/  
SuperCopper satin
- DS SuperBronzo satinato/  
SuperBronze satin
- US SuperAntracite satinato/  
SuperAnthracite satin

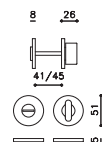

H200V6B

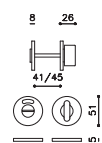

H200VF6B

Verona V Studio Oliavri



ottone/brass

- CR Cromo lucido/Bright chrome
- CO Cromo satinato/Satin chrome
- ZL SuperOro lucido/SuperGold bright
- TS SuperOro satinato/SuperGold satin
- NL SuperNichel lucido/SuperNickel bright
- NS SuperNichel satinato/SuperNickel satin
- IS SuperInox satinato/  
SuperStainlessSteel satin
- RS SuperRame satinato/  
SuperCopper satin
- DS SuperBronzo satinato/  
SuperBronze satin
- US SuperAntracite satinato/  
SuperAnthracite satin

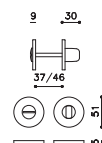

H106V6B

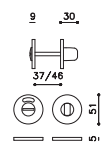

H106VF6B

## Cubo S Studio Olivari



### ottone/brass

CR Cromo lucido/Bright chrome  
 CO Cromo satinato/Satin chrome  
 ZL SuperOro lucido/SuperGold bright  
 NL SuperNichel lucido/SuperNickel bright  
 NS SuperNichel satinato/SuperNickel satin  
 IS SuperInox satinato/  
 SuperStainlessSteel satin  
 RS SuperRame satinato/  
 SuperCopper satin  
 DS SuperBronzo satinato/  
 SuperBronze satin  
 US SuperAntracite satinato/  
 SuperAnthracite satin

14 23



H135B6

## Link S Piero Lissoni



### ottone/brass

CR Cromo lucido/Bright chrome  
 CO Cromo satinato/Satin chrome  
 ZL SuperOro lucido/SuperGold bright  
 TS SuperOro satinato/SuperGold satin  
 NL SuperNichel lucido/SuperNickel bright  
 NS SuperNichel satinato/SuperNickel satin  
 IS SuperInox satinato/  
 SuperStainlessSteel satin  
 RS SuperRame satinato/  
 SuperCopper satin  
 DS SuperBronzo satinato/  
 SuperBronze satin  
 US SuperAntracite satinato/  
 SuperAnthracite satin

13 21



H199B6

## Space S Studio Olivari



### ottone/brass

CR Cromo lucido/Bright chrome  
 CO Cromo satinato/Satin chrome  
 ZL SuperOro lucido/SuperGold bright  
 TS SuperOro satinato/SuperGold satin  
 NL SuperNichel lucido/SuperNickel bright  
 NS SuperNichel satinato/SuperNickel satin  
 IS SuperInox satinato/  
 SuperStainlessSteel satin  
 RS SuperRame satinato/  
 SuperCopper satin  
 DS SuperBronzo satinato/  
 SuperBronze satin  
 US SuperAntracite satinato/  
 SuperAnthracite satin

13 21



H192B6

## Verona S Studio Olivari



### ottone/brass

CR Cromo lucido/Bright chrome  
 CO Cromo satinato/Satin chrome  
 NP Nero opaco/Mat black  
 ZL SuperOro lucido/SuperGold bright  
 TS SuperOro satinato/SuperGold satin  
 NL SuperNichel lucido/SuperNickel bright  
 NS SuperNichel satinato/SuperNickel satin  
 IS SuperInox satinato/  
 SuperStainlessSteel satin  
 RS SuperRame satinato/  
 SuperCopper satin  
 DS SuperBronzo satinato/  
 SuperBronze satin  
 US SuperAntracite satinato/  
 SuperAnthracite satin

14 25



H105B6



# Giotto Q Studio Olivari



**ottone/brass**

- CR Cromo lucido /Bright chrome
- CO Cromo satinato/Satin chrome
- CA Cromo lucido-satinato/  
Chrome bright-satin
- ZL SuperOro lucido/SuperGold bright
- TS SuperOro satinato/SuperGold satin
- NL SuperNichel lucido/  
SuperNickel bright
- NS SuperNichel satinato/  
SuperNickel satin
- IS SuperInox satinato/  
SuperStainlessSteel satin
- RS SuperRame satinato/  
SuperCopper satin
- DS SuperBronzo satinato/  
SuperBronze satin
- US SuperAntracite satinato/  
SuperAnthracite satin

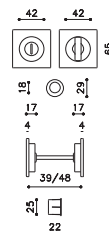

D127



**ottone/brass**

- CR Cromo lucido /Bright chrome
- CO Cromo satinato/Satin chrome
- CA Cromo lucido-satinato/  
Chrome bright-satin
- ZL SuperOro lucido/SuperGold bright
- TS SuperOro satinato/SuperGold satin
- NL SuperNichel lucido/  
SuperNickel bright
- NS SuperNichel satinato/  
SuperNickel satin
- IS SuperInox satinato/  
SuperStainlessSteel satin
- RS SuperRame satinato/  
SuperCopper satin
- DS SuperBronzo satinato/  
SuperBronze satin
- US SuperAntracite satinato/  
SuperAnthracite satin

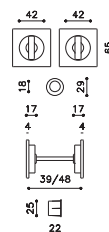

D128



**ottone/brass**

- CR Cromo lucido /Bright chrome
- CO Cromo satinato/Satin chrome
- CA Cromo lucido-satinato/  
Chrome bright-satin
- ZL SuperOro lucido/SuperGold bright
- TS SuperOro satinato/SuperGold satin
- NL SuperNichel lucido/  
SuperNickel bright
- NS SuperNichel satinato/  
SuperNickel satin
- IS SuperInox satinato/  
SuperStainlessSteel satin
- RS SuperRame satinato/  
SuperCopper satin
- DS SuperBronzo satinato/  
SuperBronze satin
- US SuperAntracite satinato/  
SuperAnthracite satin

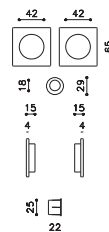

D129



**ottone/brass**

- CR Cromo lucido /Bright chrome
- CO Cromo satinato/Satin chrome
- CA Cromo lucido-satinato/  
Chrome bright-satin
- ZL SuperOro lucido/SuperGold bright
- TS SuperOro satinato/SuperGold satin
- NL SuperNichel lucido/  
SuperNickel bright
- NS SuperNichel satinato/  
SuperNickel satin
- IS SuperInox satinato/  
SuperStainlessSteel satin
- RS SuperRame satinato/  
SuperCopper satin
- DS SuperBronzo satinato/  
SuperBronze satin
- US SuperAntracite satinato/  
SuperAnthracite satin

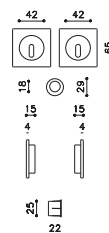

D130

# Giotto Nicola Novelletto



**ottone/brass**

- CR Cromo lucido /Bright chrome
- CO Cromo satinato/Satin chrome
- CA Cromo lucido-satinato/  
Chrome bright-satin
- ZL SuperOro lucido/SuperGold bright
- NS SuperNichel satinato/  
SuperNickel satin
- IS SuperInox satinato/  
SuperStainlessSteel satin

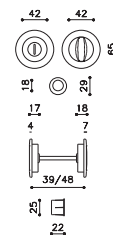

D122



**ottone/brass**

- CR Cromo lucido /Bright chrome
- CO Cromo satinato/Satin chrome
- CA Cromo lucido-satinato/  
Chrome bright-satin
- ZL SuperOro lucido/SuperGold bright
- NS SuperNichel satinato/  
SuperNickel satin
- IS SuperInox satinato/  
SuperStainlessSteel satin

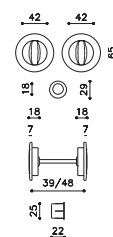

D123



**ottone/brass**

- CR Cromo lucido /Bright chrome
- CO Cromo satinato/Satin chrome
- CA Cromo lucido-satinato/  
Chrome bright-satin
- ZL SuperOro lucido/SuperGold bright
- NS SuperNichel satinato/  
SuperNickel satin
- IS SuperInox satinato/  
SuperStainlessSteel satin

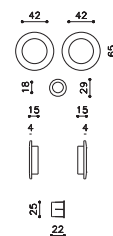

D124



**ottone/brass**

- CR Cromo lucido /Bright chrome
- CO Cromo satinato/Satin chrome
- CA Cromo lucido-satinato/  
Chrome bright-satin
- ZL SuperOro lucido/SuperGold bright
- NS SuperNichel satinato/  
SuperNickel satin
- IS SuperInox satinato/  
SuperStainlessSteel satin

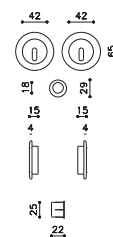

D125



# Dante Studio Olivari



**ottone/brass**

- CR Cromo lucido /Bright chrome
- CO Cromo satinato/Satin chrome
- CA Cromo lucido-satinato/  
Chrome bright-satin
- ZL SuperOro lucido/SuperGold bright
- TS SuperOro satinato/SuperGold satin
- NL SuperNichel lucido/  
SuperNickel bright
- NS SuperNichel satinato/  
SuperNickel satin
- IS SuperInox satinato/  
SuperStainlessSteel satin
- RS SuperRame satinato/  
SuperCopper satin
- DS SuperBronzo satinato/  
SuperBronze satin
- US SuperAntracite satinato/  
SuperAnthracite satin

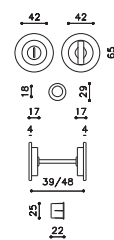

D132



**ottone/brass**

- CR Cromo lucido /Bright chrome
- CO Cromo satinato/Satin chrome
- CA Cromo lucido-satinato/  
Chrome bright-satin
- ZL SuperOro lucido/SuperGold bright
- TS SuperOro satinato/SuperGold satin
- NL SuperNichel lucido/  
SuperNickel bright
- NS SuperNichel satinato/  
SuperNickel satin
- IS SuperInox satinato/  
SuperStainlessSteel satin
- RS SuperRame satinato/  
SuperCopper satin
- DS SuperBronzo satinato/  
SuperBronze satin
- US SuperAntracite satinato/  
SuperAnthracite satin

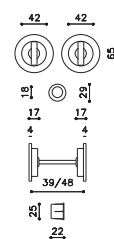

D133



**ottone/brass**

- CR Cromo lucido /Bright chrome
- CO Cromo satinato/Satin chrome
- CA Cromo lucido-satinato/  
Chrome bright-satin
- ZL SuperOro lucido/SuperGold bright
- TS SuperOro satinato/SuperGold satin
- NL SuperNichel lucido/  
SuperNickel bright
- NS SuperNichel satinato/  
SuperNickel satin
- IS SuperInox satinato/  
SuperStainlessSteel satin
- RS SuperRame satinato/  
SuperCopper satin
- DS SuperBronzo satinato/  
SuperBronze satin
- US SuperAntracite satinato/  
SuperAnthracite satin

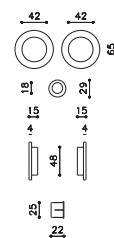

D134



**ottone/brass**

- CR Cromo lucido /Bright chrome
- CO Cromo satinato/Satin chrome
- CA Cromo lucido-satinato/  
Chrome bright-satin
- ZL SuperOro lucido/SuperGold bright
- TS SuperOro satinato/SuperGold satin
- NL SuperNichel lucido/  
SuperNickel bright
- NS SuperNichel satinato/  
SuperNickel satin
- IS SuperInox satinato/  
SuperStainlessSteel satin
- RS SuperRame satinato/  
SuperCopper satin
- DS SuperBronzo satinato/  
SuperBronze satin
- US SuperAntracite satinato/  
SuperAnthracite satin

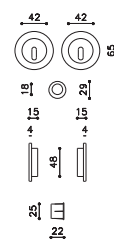

D135

## Siro Studio Olivari



**ottone/brass**

- CR Cromo lucido /Bright chrome
- CO Cromo satinato/Satin chrome
- ZL SuperOro lucido/SuperGold bright
- TS SuperOro satinato/SuperGold satin
- NL SuperNichel lucido/SuperNickel bright
- NS SuperNichel satinato/SuperNickel satin
- IS SuperInox satinato/SuperStainlessSteel satin
- RS SuperRame satinato/SuperCopper satin
- DS SuperBronzo satinato/SuperBronze satin
- US SuperAntracite satinato/SuperAnthracite satin

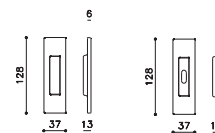

D111

D111F

## Vico Studio Olivari



**ottone/brass**

- CR Cromo lucido /Bright chrome
- CO Cromo satinato/Satin chrome
- ZL SuperOro lucido/SuperGold bright
- TS SuperOro satinato/SuperGold satin
- NL SuperNichel lucido/SuperNickel bright
- NS SuperNichel satinato/SuperNickel satin
- IS SuperInox satinato/SuperStainlessSteel satin
- RS SuperRame satinato/SuperCopper satin
- DS SuperBronzo satinato/SuperBronze satin
- US SuperAntracite satinato/SuperAnthracite satin

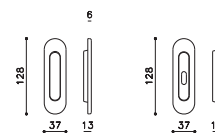

D109

D109F

## Time Studio Olivari



**ottone/brass**

- CR Cromo lucido/Bright chrome
- CO Cromo satinato/Satin chrome
- ZL SuperOro lucido/SuperGold bright
- NL SuperNichel satinato/SuperNickel satin
- IS SuperInox satinato/SuperStainlessSteel satin
- US SuperAntracite satinato/SuperAnthracite satin

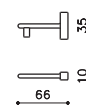

F192

## Polo Rodolfo Bonetto



**ottone/brass**

- CR Cromo lucido/Bright chrome
- CO Cromo satinato/Satin chrome
- ZL SuperOro lucido/SuperGold bright
- TS SuperOro satinato/SuperGold satin
- NS SuperNichel satinato/SuperNickel satin
- IS SuperInox satinato/SuperStainlessSteel satin
- US SuperAntracite satinato/SuperAnthracite satin



F152

## Delphina Massimo Iosa Ghini



**ottone/brass**

- CO Cromo satinato/Satin chrome
- ZL SuperOro lucido/SuperGold bright
- IS SuperInox satinato/SuperStainlessSteel satin
- US SuperAntracite satinato/SuperAnthracite satin



F158



# maniglioni

pull handles

# Planet Q Studio Olivari

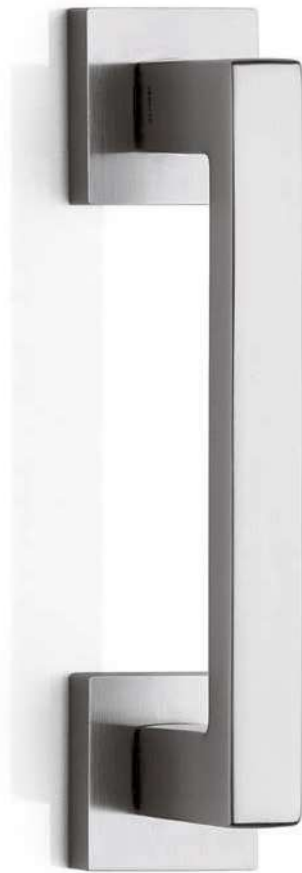

**ottone/brass**

**CR** Cromo lucido/Bright chrome

**CO** Cromo satinato/Satin chrome

**CA** Cromo lucido-satinato/  
Chrome bright-satin

**ZL** SuperOro lucido/SuperGold bright

**NL** SuperNichel lucido/  
SuperNickel bright

**NS** SuperNichel satinato/  
SuperNickel satin

**IS** SuperInox satinato/  
SuperStainlessSteel satin

**RS** SuperRame satinato/  
SuperCopper satin

**DS** SuperBronzo satinato/  
SuperBronze satin

**US** SuperAntracite satinato/  
SuperAnthracite satin

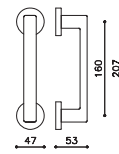

L195R

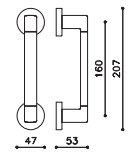

L195R

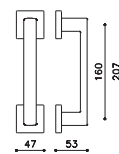

L203R

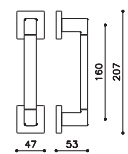

L203R



Planet Studio Olivari



**ottone/brass**

- CR Cromo lucido/Bright chrome
- CO Cromo satinato/Satin chrome
- CA Cromo lucido-satinato/Chrome bright-satin
- ZL SuperOro lucido/SuperGold bright
- NL SuperNichel lucido/SuperNickel bright
- NS SuperNichel satinato/SuperNickel satin
- IS SuperInox satinato/SuperStainlessSteel satin
- RS SuperRame satinato/SuperCopper satin
- DS SuperBronzo satinato/SuperBronze satin
- US SuperAntracite satinato/SuperAnthracite satin

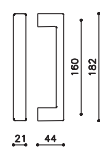

21 44



L195

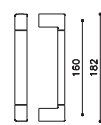

21 44



L195

# Bios Franco Sargiani



**ottone/brass**

- CR Cromo lucido/Bright chrome
- CO Cromo satinato/Satin chrome
- NL SuperNichel lucido/  
SuperNickel bright
- IS SuperInox satinato/  
SuperStainlessSteel satin
- RS SuperRame satinato/  
SuperCopper satin
- DS SuperBronzo satinato/  
SuperBronze satin

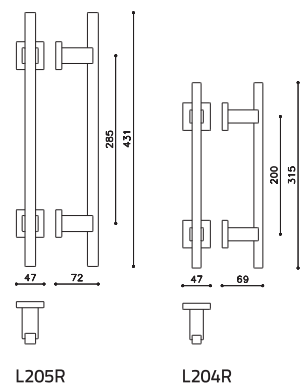



Bios Franco Sargiani



ottone/brass

- CR Cromo lucido/Bright chrome
- CO Cromo satinato/Satin chrome
- NL SuperNichel lucido/  
SuperNickel bright
- IS SuperInox satinato/  
SuperStainlessSteel satin
- RS SuperRame satinato/  
SuperCopper satin
- DS SuperBronzo satinato/  
SuperBronze satin

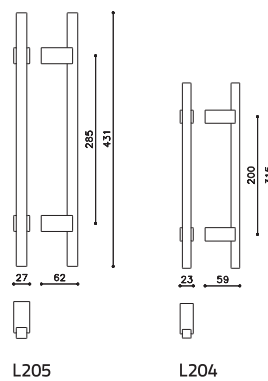

Diana Studio Olivari

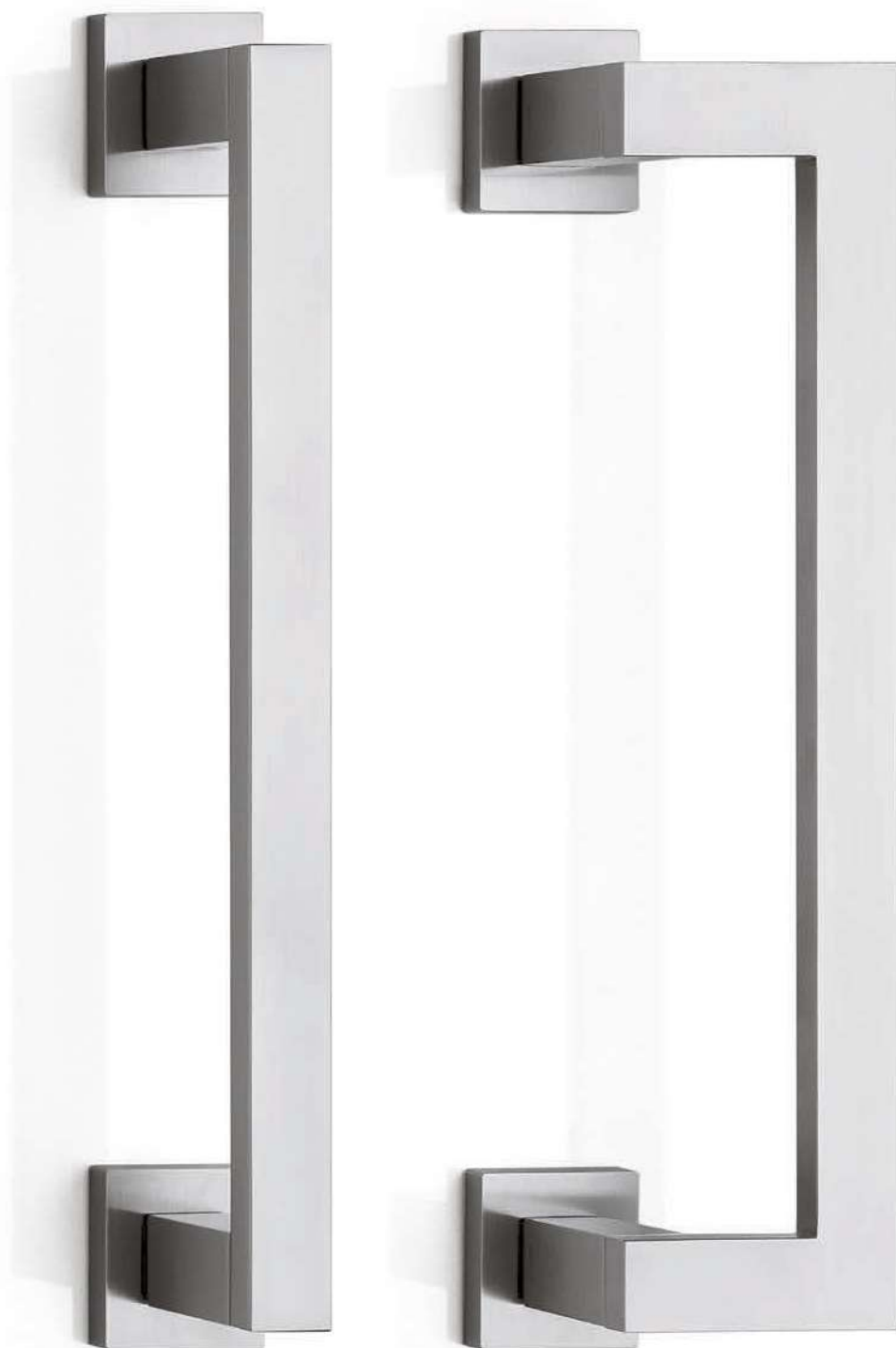

ottone/brass

- CR Cromo lucido/Bright chrome
- CO Cromo satinato/Satin chrome
- NL SuperNichel lucido/  
SuperNickel bright
- IS SuperInox satinato/  
SuperStainlessSteel satin
- RS SuperRame satinato/  
SuperCopper satin
- DS SuperBronzo satinato/  
SuperBronze satin
- US SuperAntracite satinato/  
SuperAnthracite satin

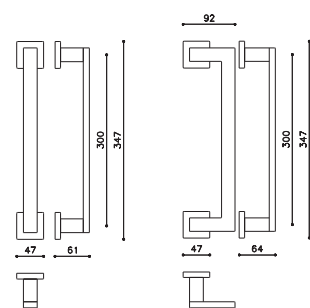

L206R

L207R



Diana Studio Olivari

ottone/brass

- CR Cromo lucido/Bright chrome
- CO Cromo satinato/Satin chrome
- NL SuperNichel lucido/  
SuperNickel bright
- IS SuperInox satinato/  
SuperStainlessSteel satin
- RS SuperRame satinato/  
SuperCopper satin
- DS SuperBronzo satinato/  
SuperBronze satin
- US SuperAntracite satinato/  
SuperAnthracite satin

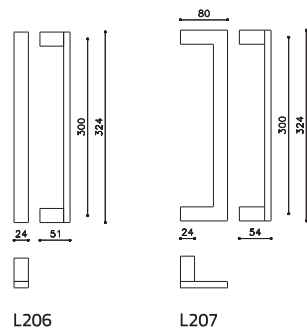

# Link Pietro Lissoni



**ottone/brass**

- CR** Cromo lucido/Bright chrome
- CO** Cromo satinato/Satin chrome
- NL** SuperNichel lucido/  
SuperNickel bright
- IS** SuperInox satinato/  
SuperStainlessSteel satin
- RS** SuperRame satinato/  
SuperCopper satin
- DS** SuperBronzo satinato/  
SuperBronze satin
- US** SuperAntracite satinato/  
SuperAnthracite satin

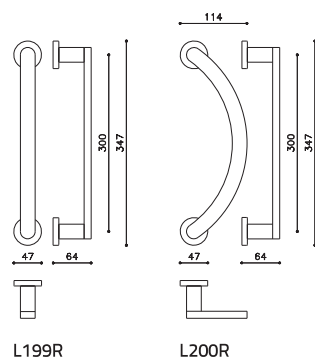



Link Pietro Lissoni

**ottone/brass**

- CR** Cromo lucido/Bright chrome
- CO** Cromo satinato/Satin chrome
- NL** SuperNichel lucido/  
SuperNickel bright
- IS** SuperInox satinato/  
SuperStainlessSteel satin
- RS** SuperRame satinato/  
SuperCopper satin
- DS** SuperBronzo satinato/  
SuperBronze satin
- US** SuperAntracite satinato/  
SuperAnthracite satin

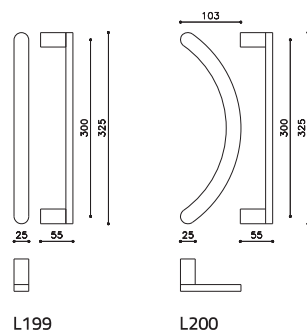

Stilo Enzo Mari

ottone/brass

- CR Cromo lucido/Bright chrome
- CO Cromo satinato/Satin chrome
- NL SuperNichel lucido/  
SuperNickel bright
- IS SuperInox satinato/  
SuperStainlessSteel satin
- RS SuperRame satinato/  
SuperCopper satin
- DS SuperBronzo satinato/  
SuperBronze satin

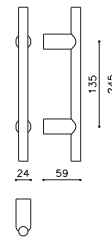

L189

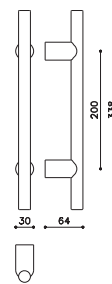

L190M

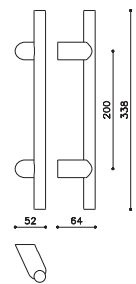

L191M



Stilo Enzo Mari



ottone/brass

- CR Cromo lucido/Bright chrome
- CO Cromo satinato/Satin chrome
- IS SuperInox satinato/  
SuperStainlessSteel satin

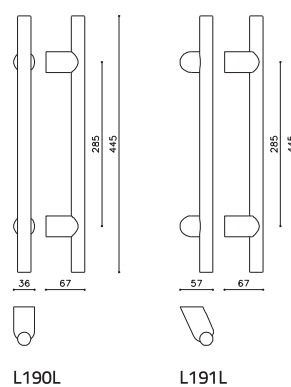

# Alexandra F.A. Porsche

ottone/brass

CR Cromo lucido/Bright chrome  
CO Cromo satinato/Satin chrome  
IS SuperInox satinato/  
SuperStainlessSteel satin

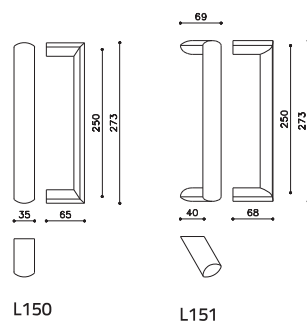



Aster Studio Olivari

ottone/brass

CA Cromo lucido-satinato/  
Chrome bright-satin

ZT SuperOro lucido-satinato/  
SuperGold bright-satin

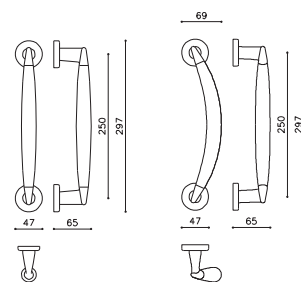

L174R

L175R

# Edison

Mazza, Gramigna

**ottone/brass**

**CR** cromato /chrome

**CO** Cromo satinato/Satin chrome

**ZL** SuperOro lucido/SuperGold bright

**IS** SuperInox satinato/  
SuperStainlessSteel satin

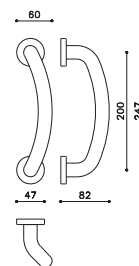

L147R

# Bond

Andrea Branzi

ottone/brass

CO Cromo satinato/Satin chrome

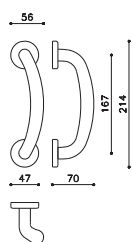

L163R

# Icaro

Paolo Portoghesi

ottone/brass

ZL SuperOro lucido/SuperGold bright

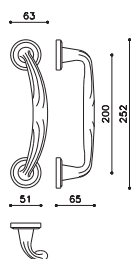

L168A





# maniglioni alzanti

pull-up handles

# Planet Q Studio Olivari

# Planet Q corto Studio Olivari



**ottone/brass**

- CR Cromo lucido/Bright chrome
- CO Cromo satinato/Satin chrome
- ZL SuperOro lucido/SuperGold bright
- TS SuperOro satinato/SuperGold satin
- NL SuperNichel lucido/  
SuperNickel bright
- NS SuperNichel satinato/  
SuperNickel satin
- IS SuperInox satinato/  
SuperStainlessSteel satin
- RS SuperRame satinato/  
SuperCopper satin
- DS SuperBronzo satinato/  
SuperBronze satin
- US SuperAntracite satinato/  
SuperAnthracite satin

**ottone/brass**

- CR Cromo lucido/Bright chrome
- CO Cromo satinato/Satin chrome
- ZL SuperOro lucido/SuperGold bright
- NS SuperNichel satinato/  
SuperNickel satin
- IS superinox satinat/  
SuperStainlessSteel satin
- US SuperAntracite satinato/  
SuperAnthracite satin

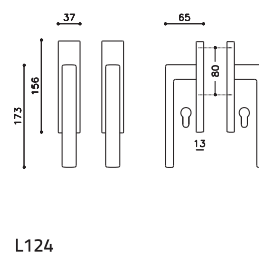
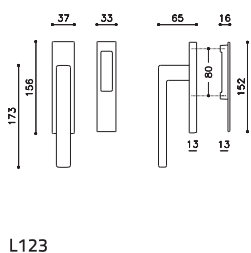
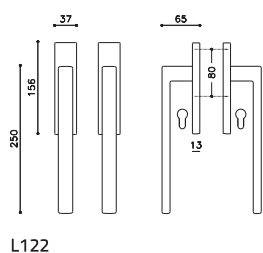
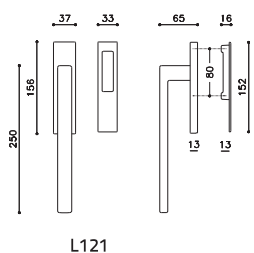



# Lotus Q Javier Lopez



**ottone/brass**

- CR Cromo lucido/Bright chrome
- CO Cromo satinato/Satin chrome
- ZL SuperOro lucido/SuperGold bright
- NL SuperNichel lucido/  
SuperNickel bright
- NS SuperNichel satinato/  
SuperNickel satin
- IS SuperInox satinato/  
SuperStainlessSteel satin
- RS SuperRame satinato/  
SuperCopper satin
- DS SuperBronzo satinato/  
SuperBronze satin
- US SuperAntracite satinato/  
SuperAnthracite satin

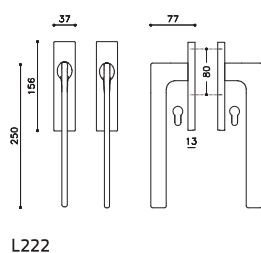
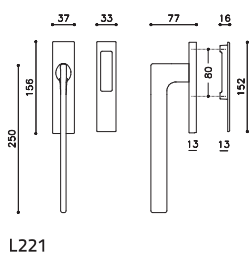

# Planet Studio Olivari

# Planet corto Studio Olivari



**ottone/brass**

- CR Cromo lucido/Bright chrome
- CO Cromo satinato/Satin chrome
- ZL SuperOro lucido/SuperGold bright
- TS SuperOro satinato/SuperGold satin
- NL SuperNichel lucido/  
SuperNickel bright
- NS SuperNichel satinato/  
SuperNickel satin
- IS SuperInox satinato/  
SuperStainlessSteel satin
- RS SuperRame satinato/  
SuperCopper satin
- DS SuperBronzo satinato/  
SuperBronze satin
- US SuperAntracite satinato/  
SuperAnthracite satin

**ottone/brass**

- CR Cromo lucido/Bright chrome
- CO Cromo satinato/Satin chrome
- ZL SuperOro lucido/SuperGold bright
- NS SuperNichel satinato/  
SuperNickel satin
- IS SuperInox satinato/  
SuperStainlessSteel satin
- US SuperAntracite satinato/  
SuperAnthracite satin

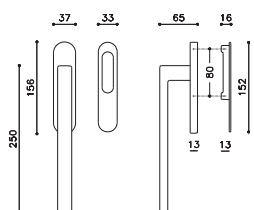

L111

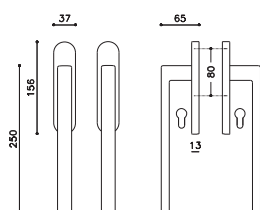

L112

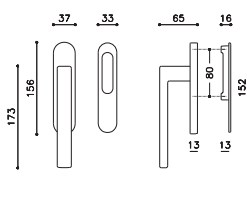

L113

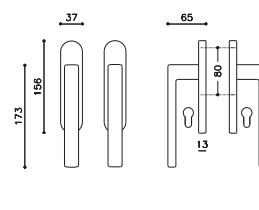

L114

Polo Studio Olivari

Polo corto Studio Olivari



ottone/brass

- CR Cromo lucido/Bright chrome
- CO Cromo satinato/Satin chrome
- ZL SuperOro lucido/SuperGold bright
- TS SuperOro satinato/SuperGold satin
- NL SuperNichel lucido/  
SuperNickel bright
- NS SuperNichel satinato/  
SuperNickel satin
- IS SuperInox satinato/  
SuperStainlessSteel satin
- RS SuperRame satinato/  
SuperCopper satin
- DS SuperBronzo satinato/  
SuperBronze satin

ottone/brass

- CR Cromo lucido/Bright chrome
- CO Cromo satinato/Satin chrome
- ZL SuperOro lucido/SuperGold bright
- IS SuperInox satinato/  
SuperStainlessSteel satin

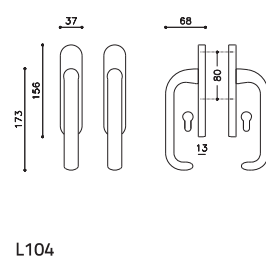
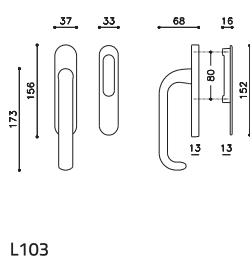
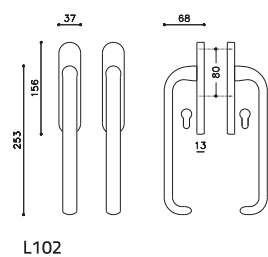
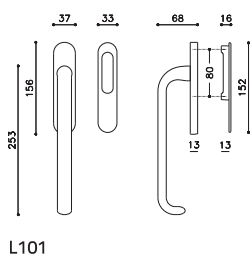



# Lotus Javier Lopez



**ottone/brass**

- CR Cromo lucido/Bright chrome
- CO Cromo satinato/Satin chrome
- ZL SuperOro lucido/SuperGold bright
- NL SuperNichel lucido/  
SuperNickel bright
- NS SuperNichel satinato/  
SuperNickel satin
- IS SuperInox satinato/  
SuperStainlessSteel satin
- RS SuperRame satinato/  
SuperCopper satin
- DS SuperBronzo satinato/  
SuperBronze satin
- US SuperAntracite satinato/  
SuperAnthracite satin

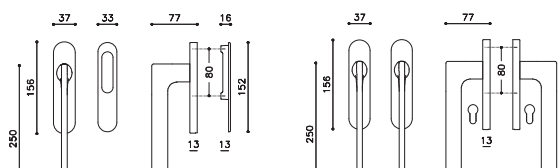

L211

L212

# Lama Gio Ponti



**ottone/brass**

- CR Cromo lucido/Bright chrome
- CO Cromo satinato/Satin chrome
- ZL SuperOro lucido/SuperGold bright
- NL SuperNichel lucido/  
SuperNickel bright
- IS SuperInox satinato/  
SuperStainlessSteel satin
- RS SuperRame satinato/  
SuperCopper satin
- DS SuperBronzo satinato/  
SuperBronze satin
- US SuperAntracite satinato/  
SuperAnthracite satin

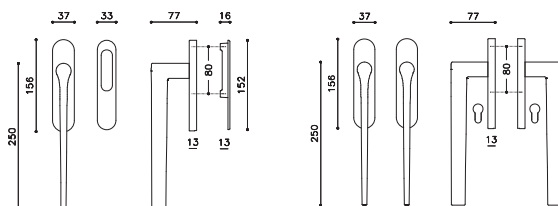

L136

L137

# Beta Joe Colombo

# Link Piro Lissoni



ottone/brass

- CR Cromo lucido/Bright chrome
- CO Cromo satinato/Satin chrome
- IS SuperInox satinato/  
SuperStainlessSteel satin

ottone/brass

- CR Cromo lucido/Bright chrome
- CO Cromo satinato/Satin chrome
- ZL SuperOro lucido/SuperGold bright
- NL SuperNichel lucido/  
SuperNickel bright
- IS SuperInox satinato/  
SuperStainlessSteel satin
- RS SuperRame satinato/  
SuperCopper satin
- DS SuperBronzo satinato/  
SuperBronze satin
- US SuperAntracite satinato/  
SuperAnthracite satin

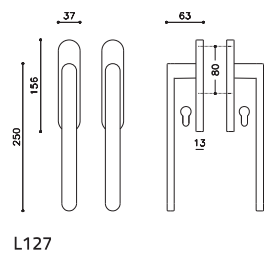
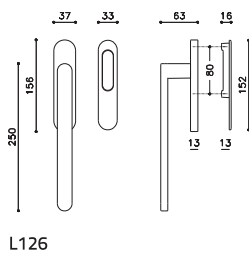
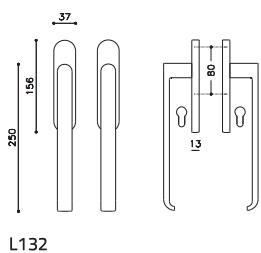
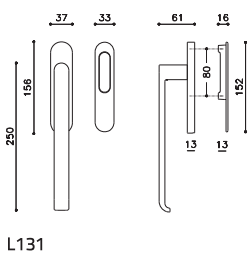





accessori

accessories

## Cubo Studio Olivari



**ottone/brass**

- CR Cromo lucido/Bright chrome
- CO Cromo satinato/Satin chrome
- ZL SuperOro lucido/SuperGold bright
- TS SuperOro satinato/SuperGold satin
- NL SuperNichel lucido/SuperNickel bright
- NS SuperNichel satinato/SuperNickel satin
- IS SuperInox satinato/SuperStainlessSteel satin
- RS SuperRame satinato/SuperCopper satin
- DS SuperBronzo satinato/SuperBronze satin
- US SuperAntracite satinato/SuperAnthracite satin

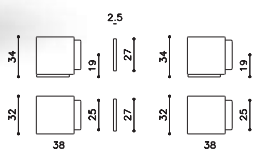

**B136C**  
magnetico/  
magnetic

**B136S**  
non magnetico/  
not magnetic

## Victor Studio Olivari



**ottone/brass**

- CR Cromo lucido/Bright chrome
- CO Cromo satinato/Satin chrome
- ZL SuperOro lucido/SuperGold bright
- TS SuperOro satinato/SuperGold satin
- NL SuperNichel lucido/SuperNickel bright
- NS SuperNichel satinato/SuperNickel satin
- IS SuperInox satinato/SuperStainlessSteel satin
- RS SuperRame satinato/SuperCopper satin
- DS SuperBronzo satinato/SuperBronze satin
- US SuperAntracite satinato/SuperAnthracite satin

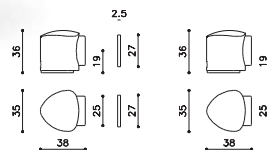

**B106C**  
magnetico/  
magnetic

**B106S**  
non magnetico/  
not magnetic

## Raffaella Studio Olivari



**ottone/brass**

- CR Cromo lucido/Bright chrome
- CO Cromo satinato/Satin chrome
- ZL SuperOro lucido/SuperGold bright
- TS SuperOro satinato/SuperGold satin
- NL SuperNichel lucido/SuperNickel bright
- NS SuperNichel satinato/SuperNickel satin
- IS SuperInox satinato/SuperStainlessSteel satin
- RS SuperRame satinato/SuperCopper satin
- DS SuperBronzo satinato/SuperBronze satin
- US SuperAntracite satinato/SuperAnthracite satin



**B102**

## Sector Studio Olivari



**ottone/brass**

- CR Cromo lucido/Bright chrome
- CO Cromo satinato/Satin chrome
- ZL SuperOro lucido/SuperGold bright
- TS SuperOro satinato/SuperGold satin
- NL SuperNichel lucido/SuperNickel bright
- NS SuperNichel satinato/SuperNickel satin
- IS SuperInox satinato/SuperStainlessSteel satin
- RS SuperRame satinato/SuperCopper satin
- DS SuperBronzo satinato/SuperBronze satin



**B101**

## Gardena Studio Olivari



**ottone/brass**

- ZL SuperOro lucido/SuperGold bright



**B103**

## Stilo Studio Olivari



**ottone/brass**

- CR Cromo lucido/Bright chrome
- CO Cromo satinato/Satin chrome
- NE Nero/Black
- ZL SuperOro lucido/SuperGold bright



**B121**

## Stilo Studio Olivari



**ottone/brass**

- CR Cromo lucido/Bright chrome
- CO Cromo satinato/Satin chrome
- ZL SuperOro lucido/SuperGold bright

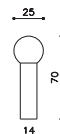

**B123**  
da parete/  
for wall

## Bond Andrea Branzi



ottone/brass

CR Cromo lucido / Bright chrome  
CO Cromo satinato / Satin chrome

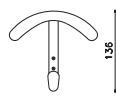

E163A

## Alexandra F.A. Porsche



ottone/brass

CR Cromo lucido / Bright chrome  
CO Cromo satinato / Satin chrome



E150

## Dora Giotto Stoppino



ottone/brass

CR Cromo lucido / Bright chrome  
CO Cromo satinato / Satin chrome  
ZL SuperOro lucido / SuperGold bright

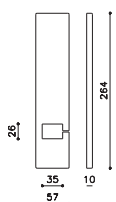

V107

## Tevere Giotto Stoppino



nylon/nylon

NE Nero / Black  
BI Bianco / White

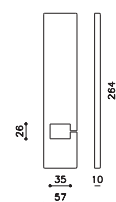

V507



Nylon

# Gamma Studio Olivari



nylon/nylon

NE Nero/Black  
BI Bianco/White

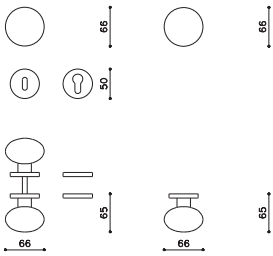

P506RB8  
P506RY8

S506RF  
S506R8

# Nemi Studio Olivari



nylon/nylon

NE Nero/Black  
BI Bianco/White

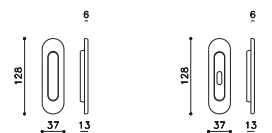

D509

D509F

# Venezia Studio Olivari



nylon/nylon

NE Nero/Black  
BI Bianco/White

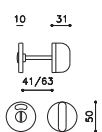

H506/6

# Boma Studio Olivari



nylon/nylon

NE Nero/Black  
BI bianco/white

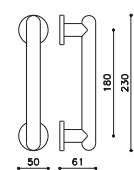

L501

# disegni tecnici

technical drawings

ABC M2155 (p.10)

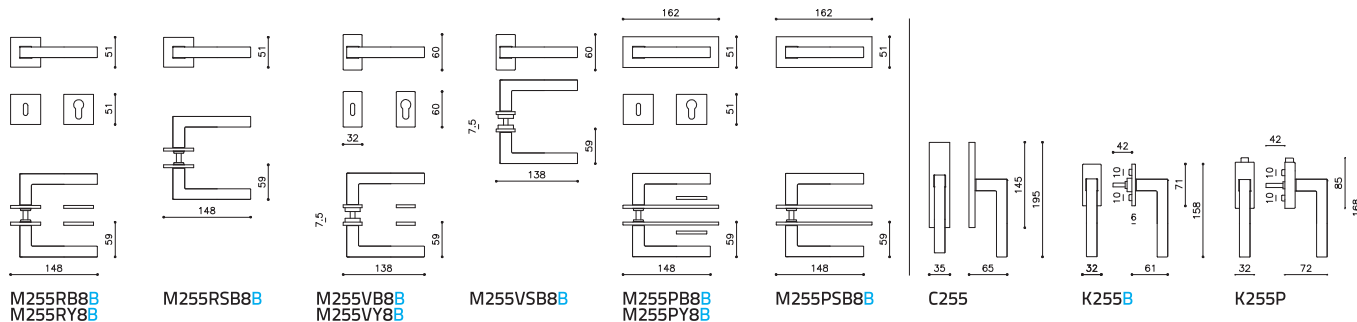

Adamant M216 (p.28)

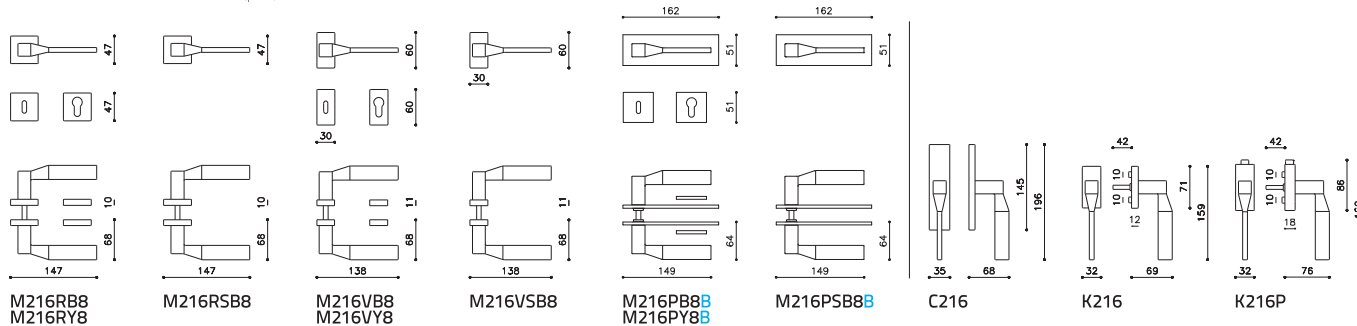

Agata M116 (p.126)

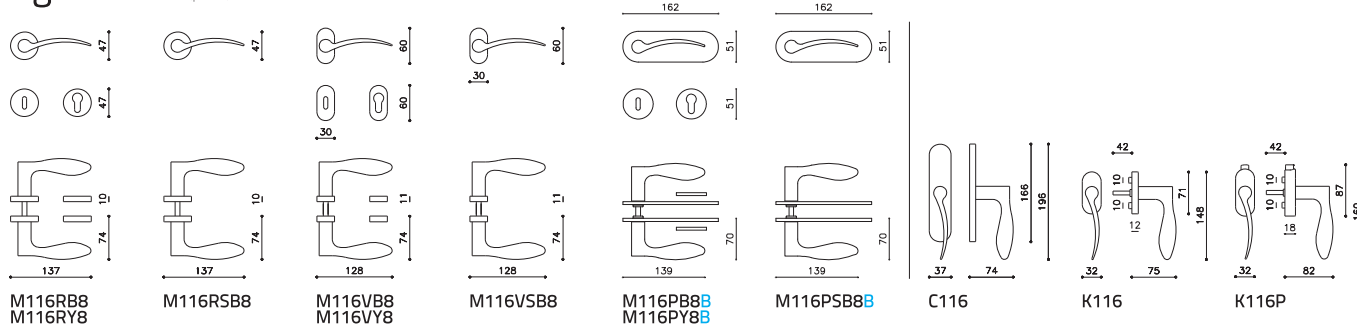

Ala M215 (p.76)

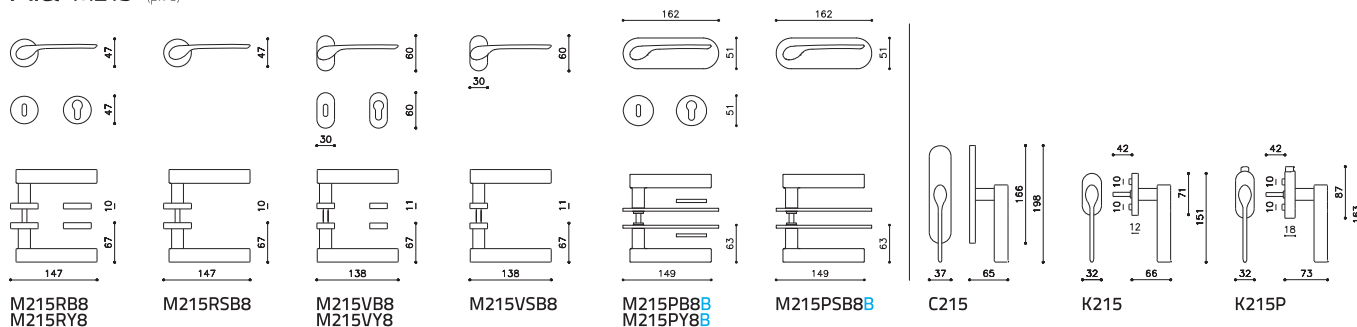

Alexandra M150 (p.66)





Arc M225 (p.48)

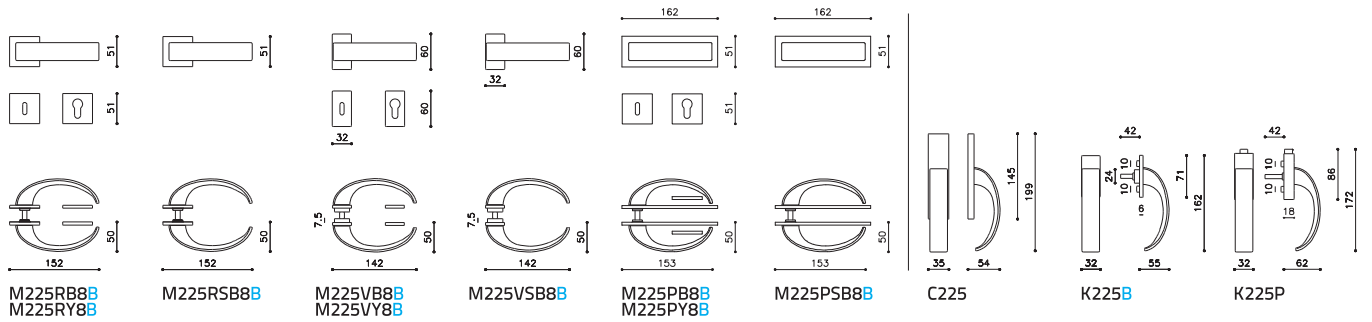

Aster M174 (p.146)

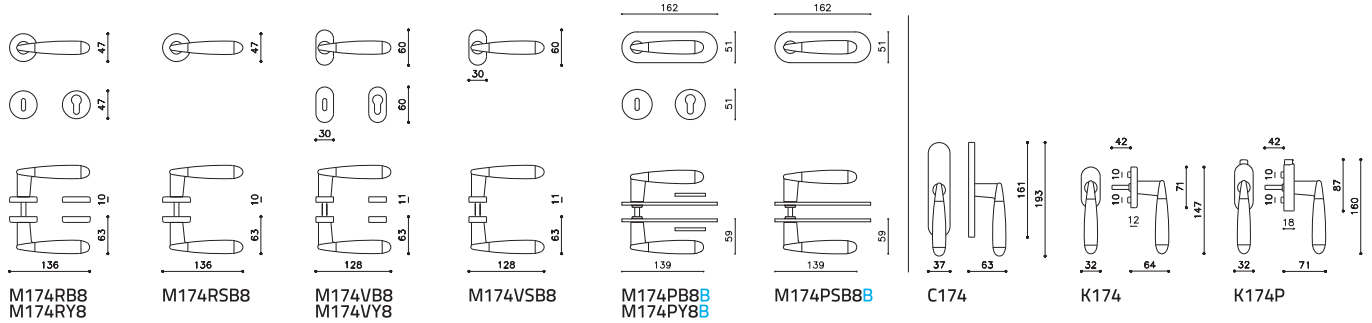

Atena Ligne M1AL (p.190)

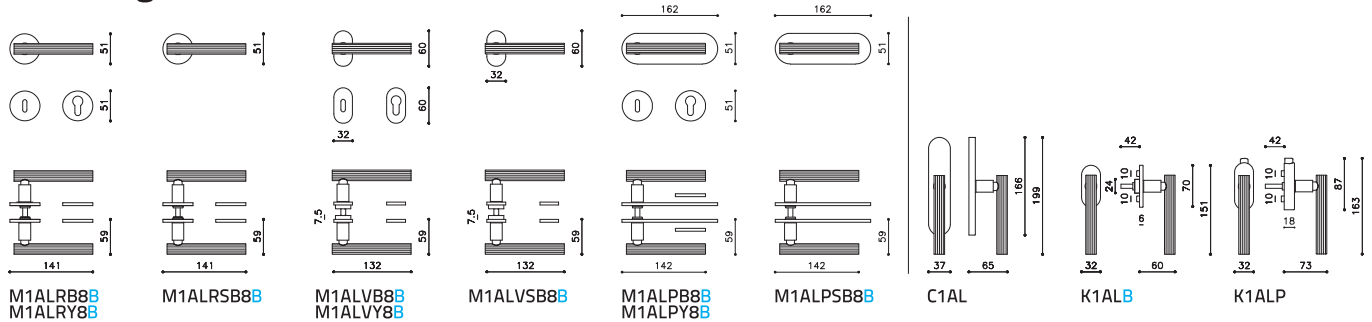

Atena Panier M1AP (p.194)

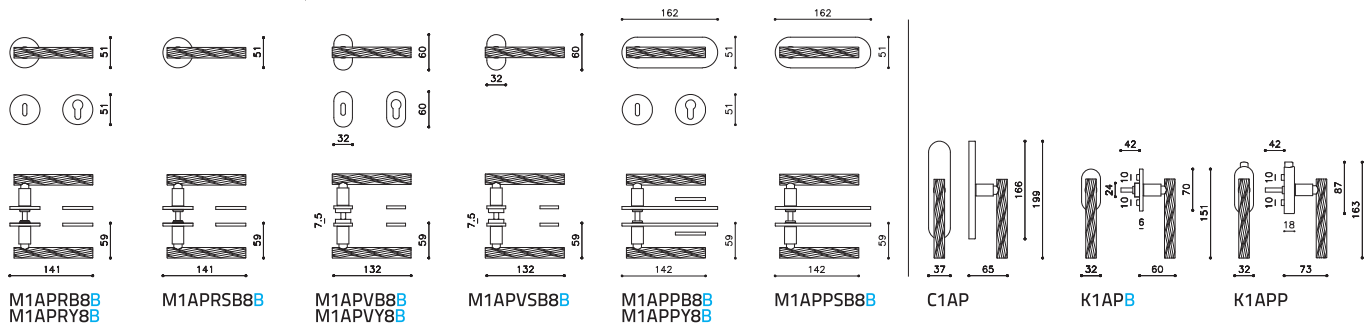

Atena Rank M1AR (p.192)

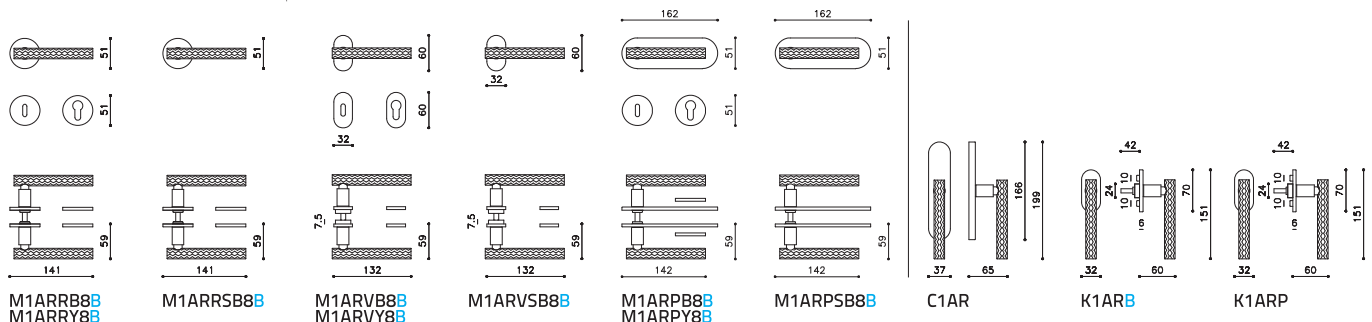

### Aurelia M185 (p.145)

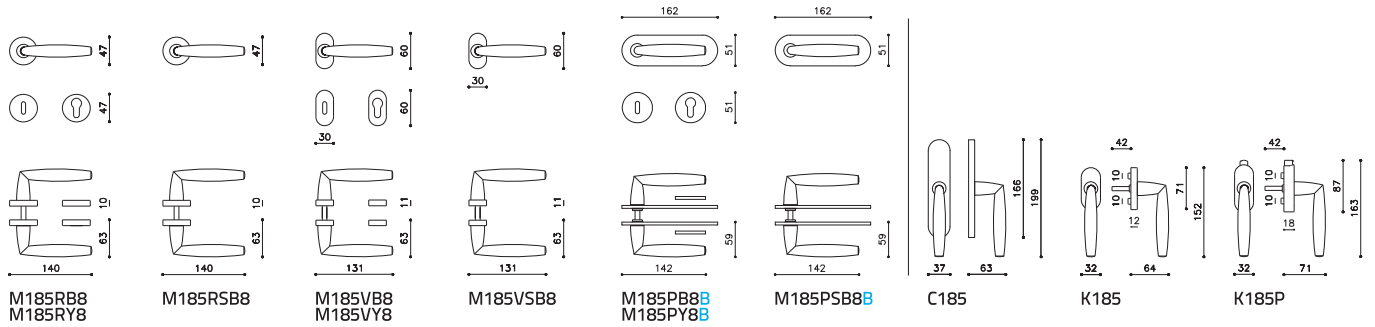

### Aurora M164 (p.170)

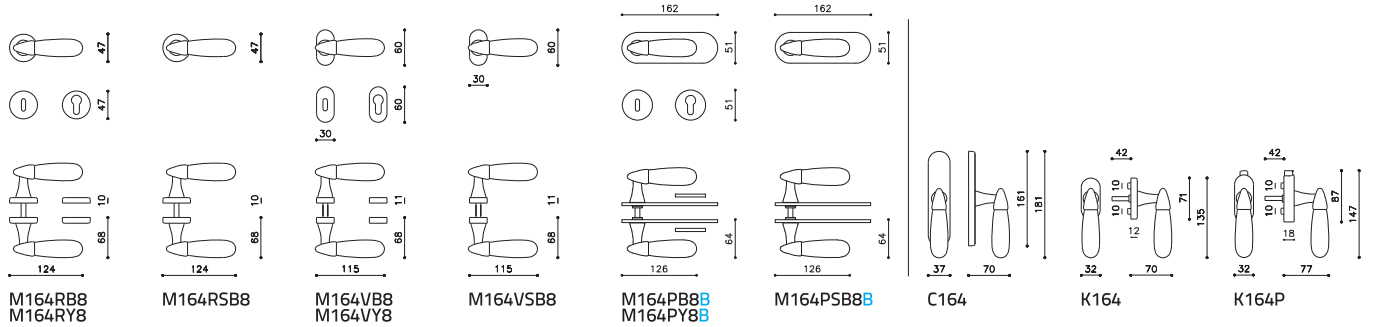

### Beijing M208 (p.88)

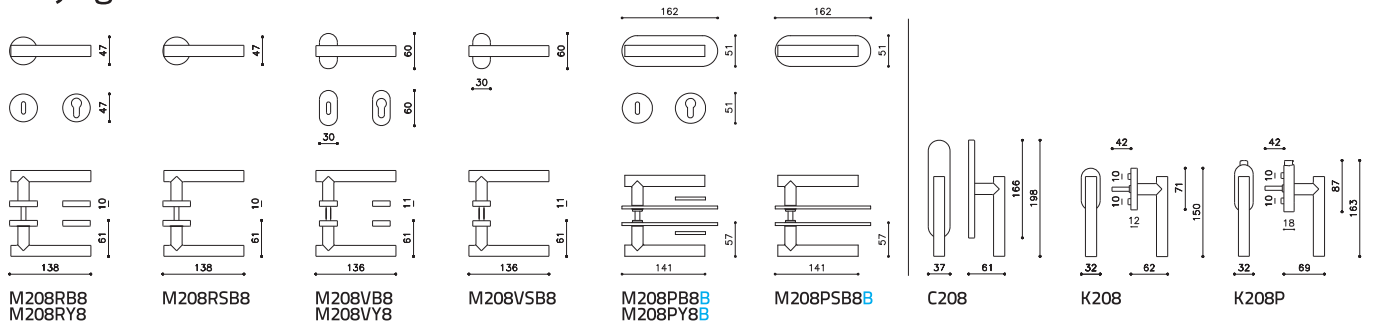

### Beta M221 (p.92)

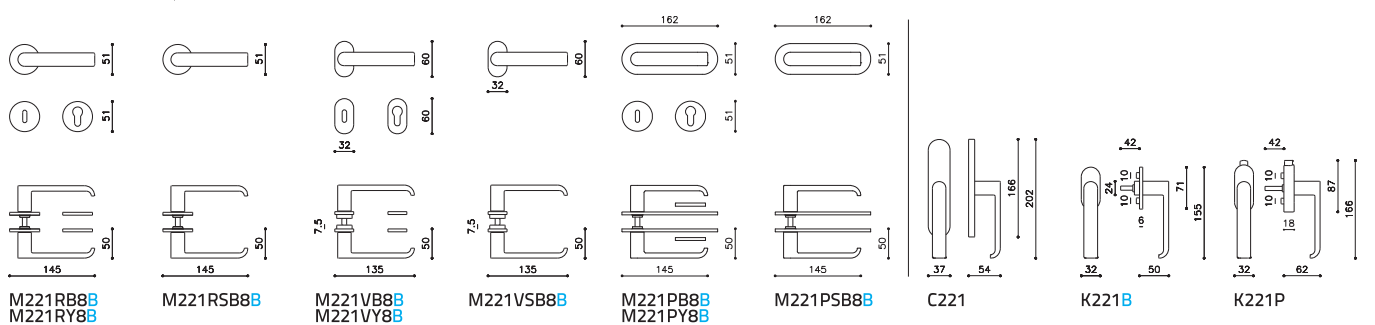

### Bios M204 (p.35)

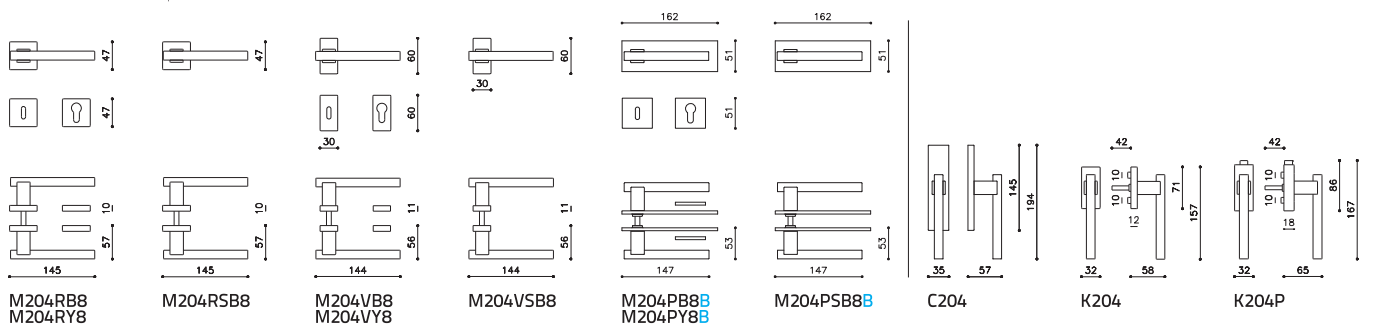





### Chevron M248 (p.16)

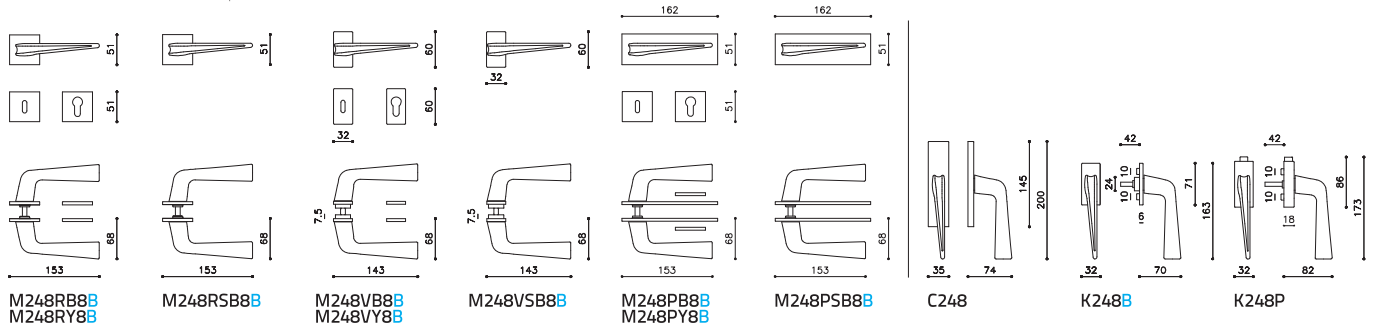

### Chiara M125 (p.114)

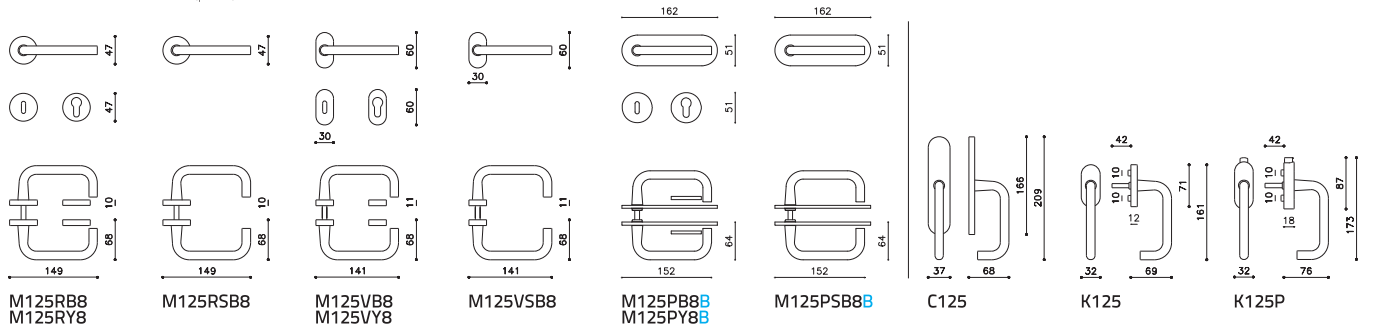

### Chiara Ny M509 (p.180)

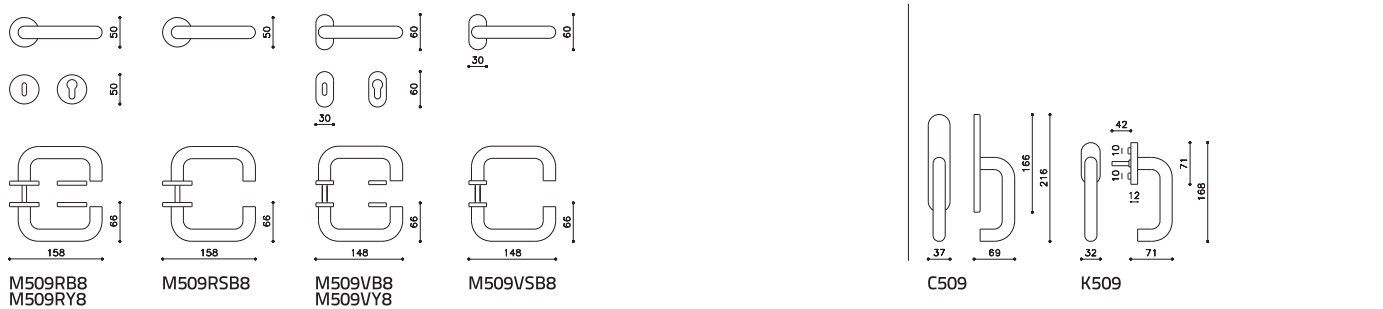

### Club M181 (p.174)

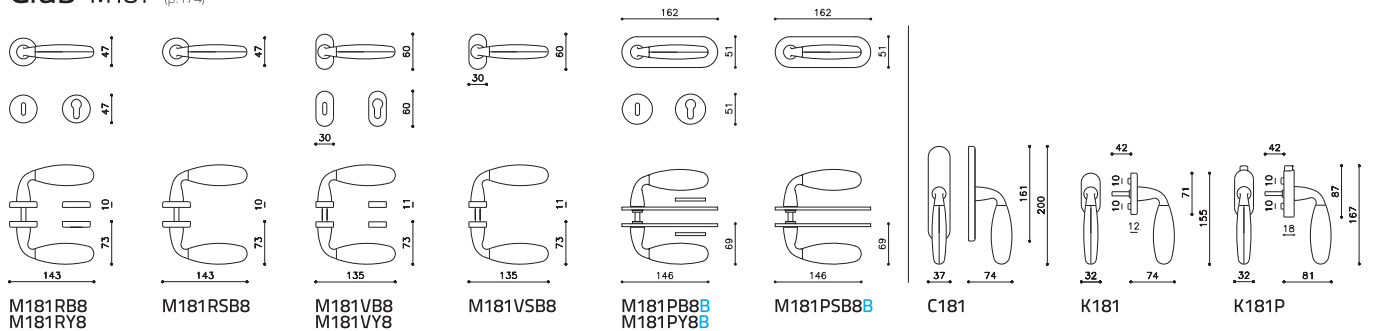

### Comet M183 (p.142)

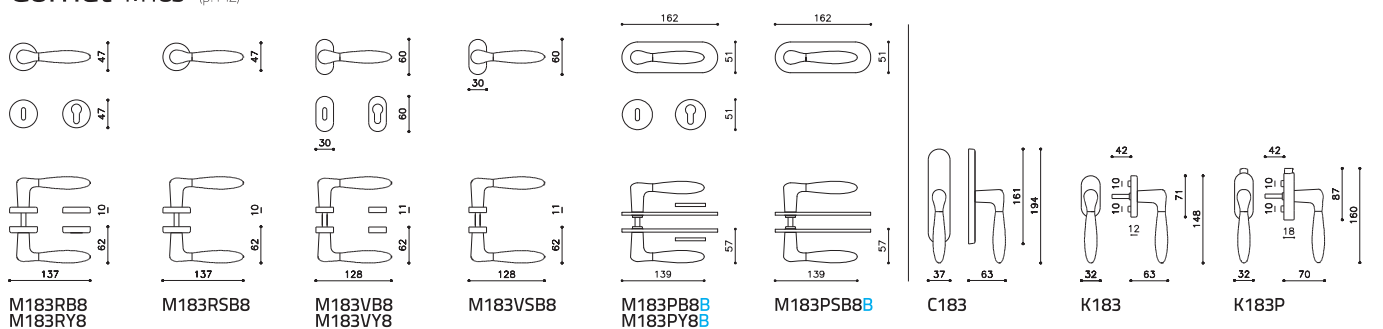

### Conca M236 (p.154)

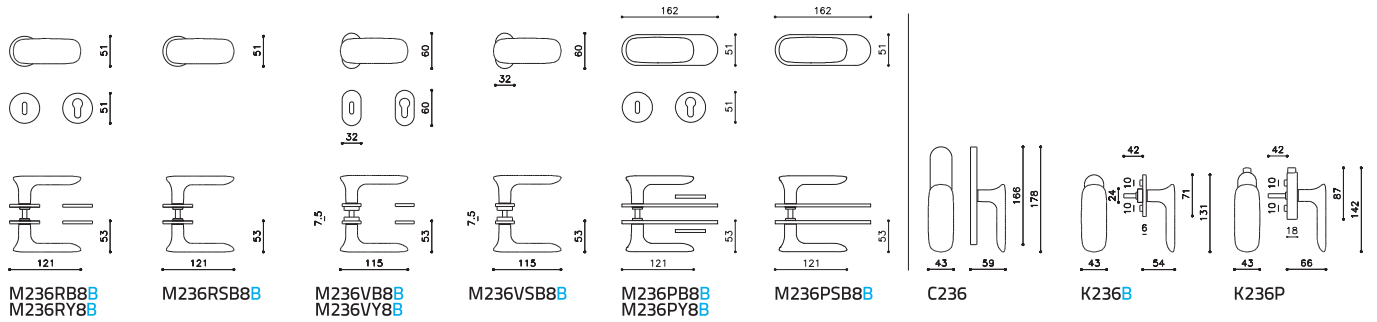

### Crystal Diamond M246 (p.166)

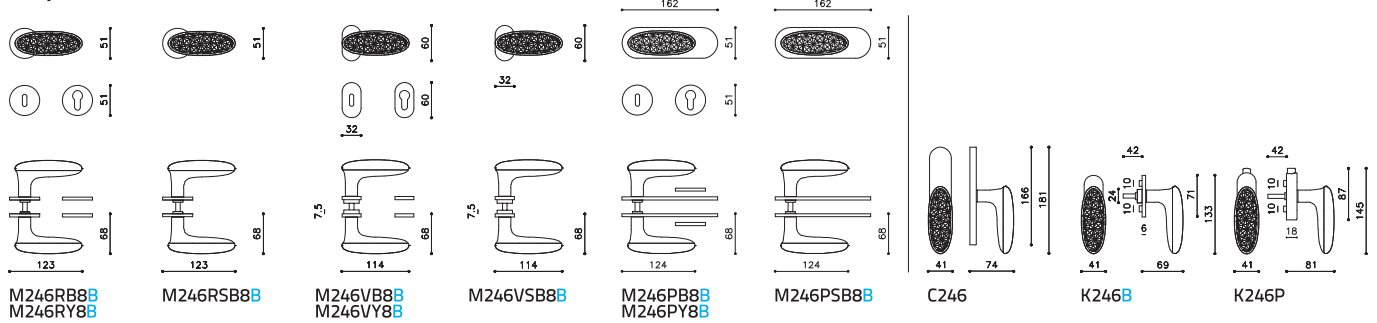

### Crystal Royal M245 (p.168)

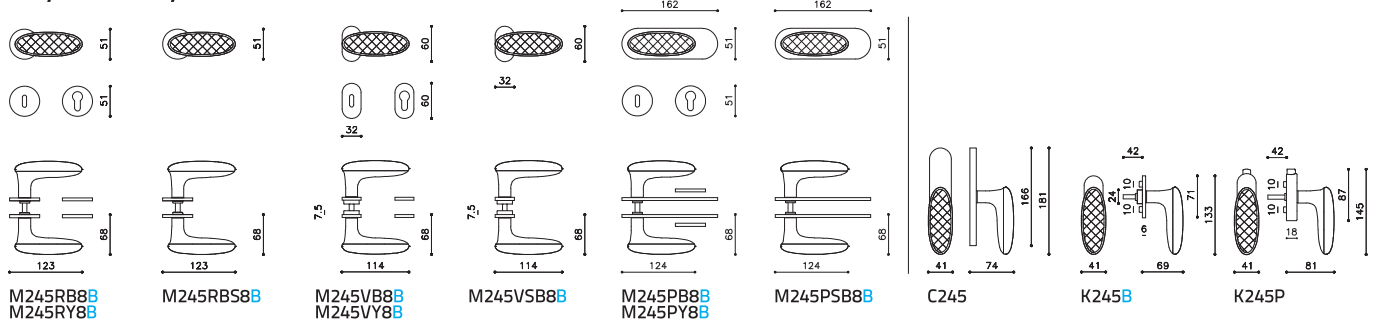

### Denver M218 (p.20)

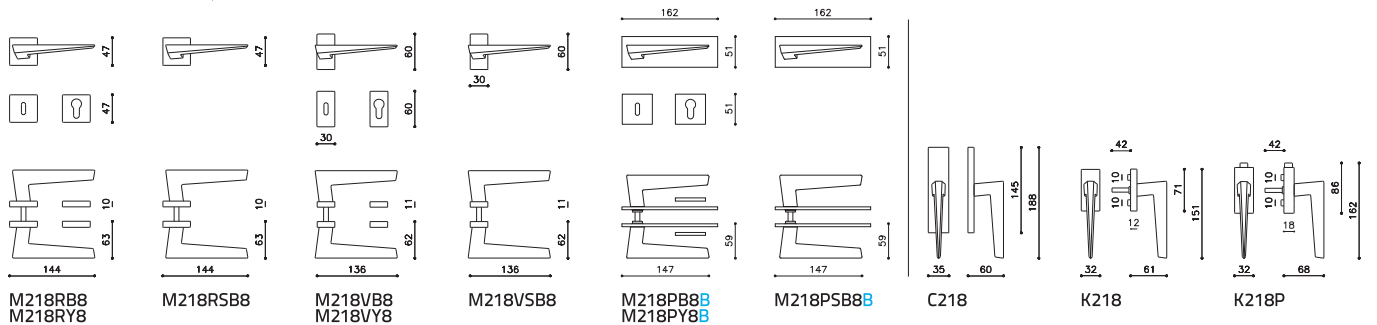

### Diana M206 (p.38)

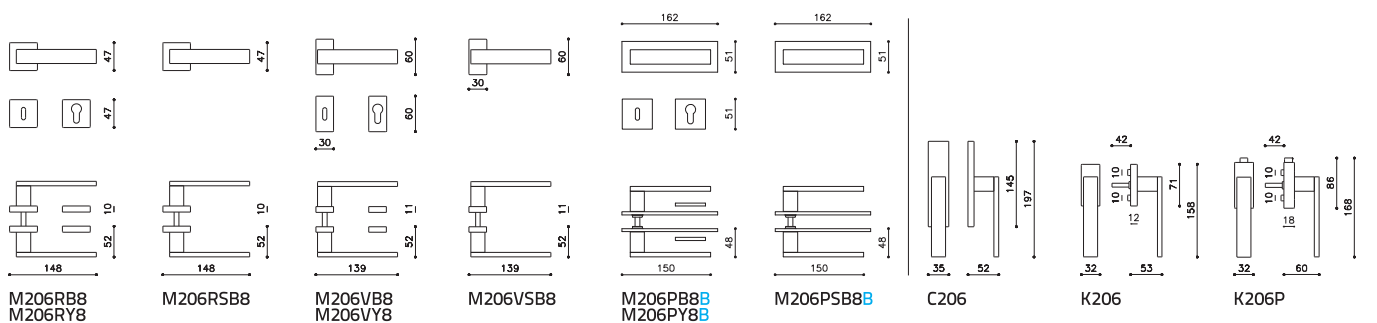

### Diana Barley M1DB (p.184)

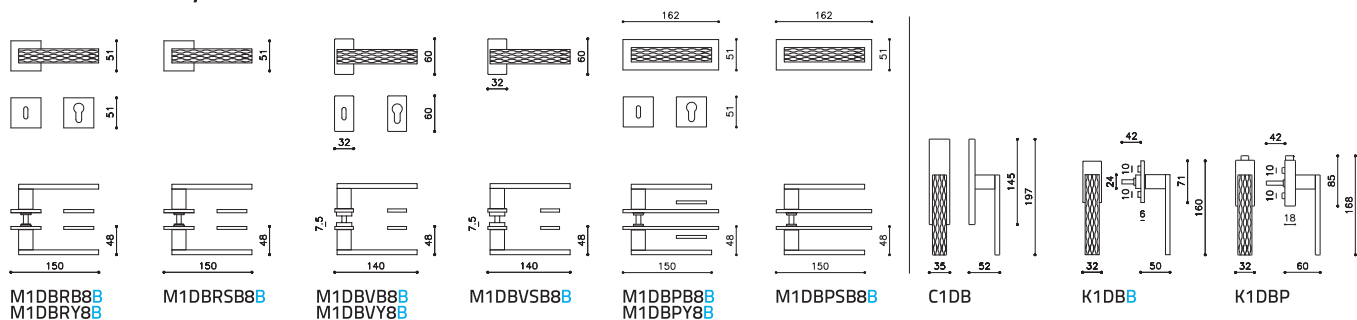

### Diana Chevron M1DC (p.188)

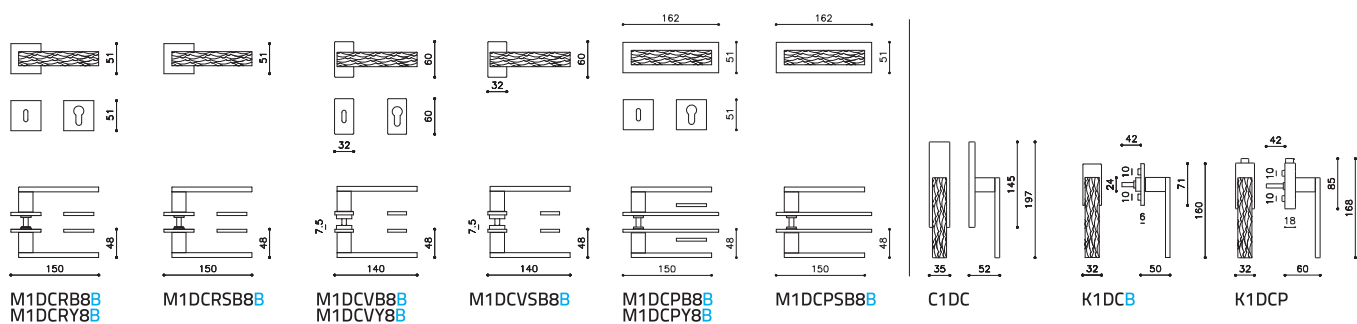

### Diana Damier M1DD (p.183)

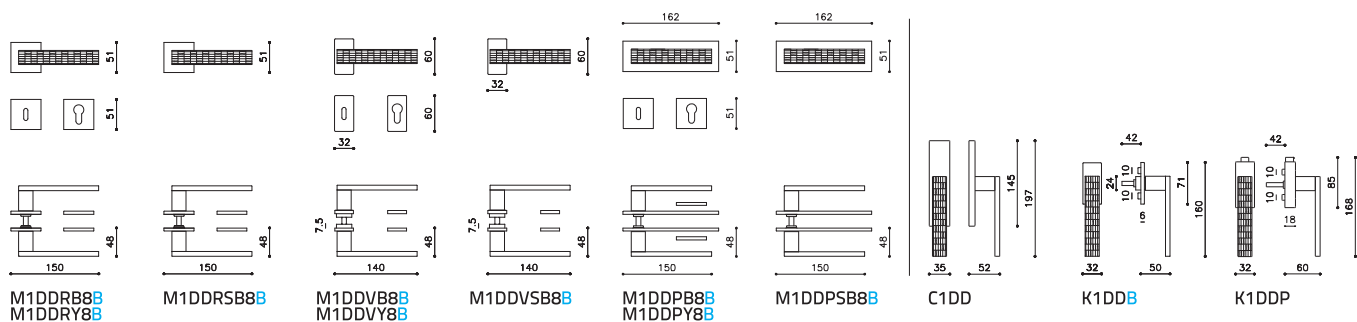

### Diva M256 (p.54)

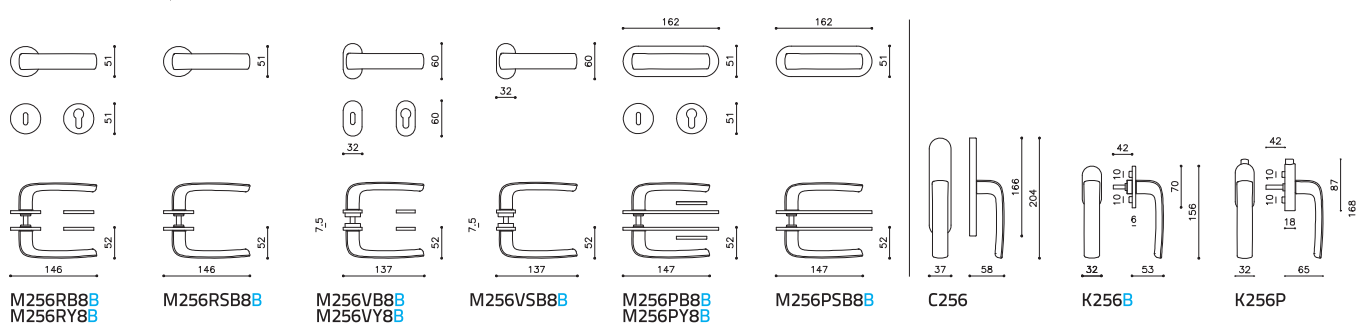

### Dolce Vita M243 (p.86)

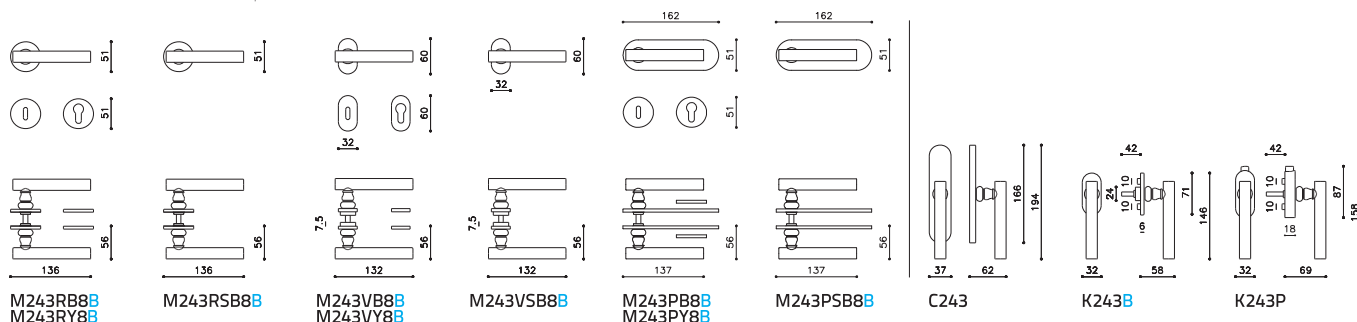



### Edge M212 (p.162)

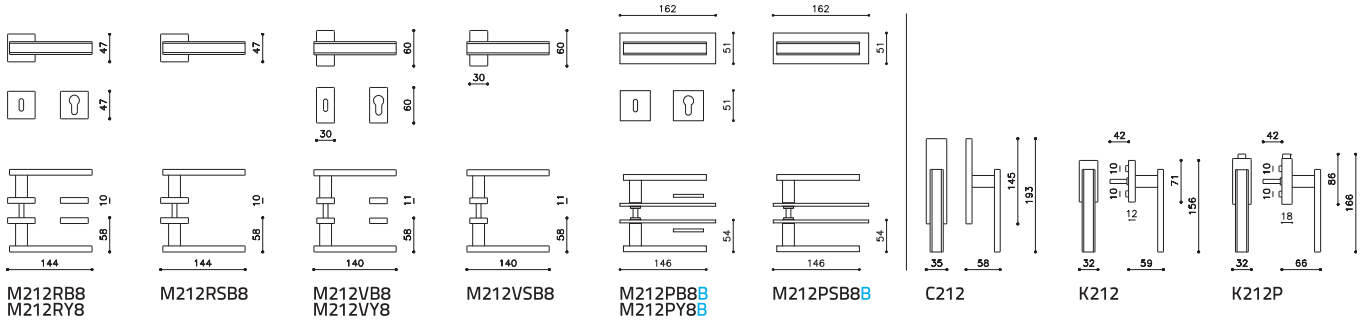

### Emilia M167 (p.137)

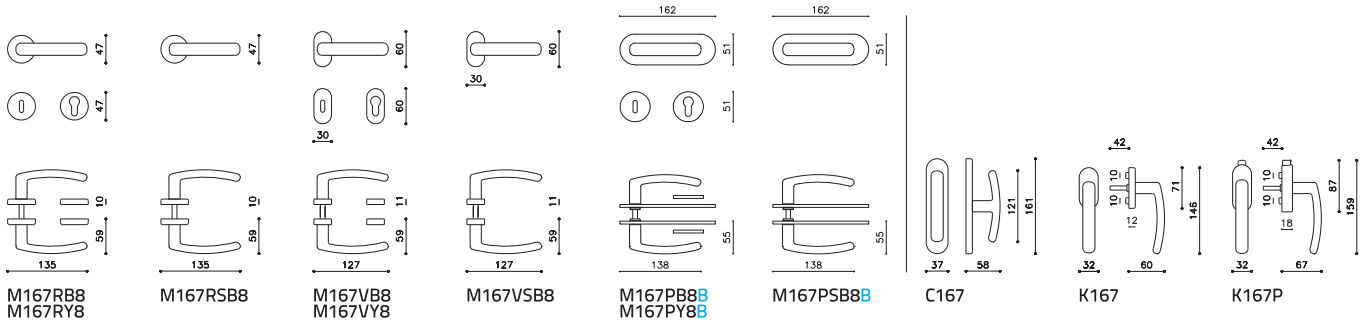

### Euclide M229 (p.44)

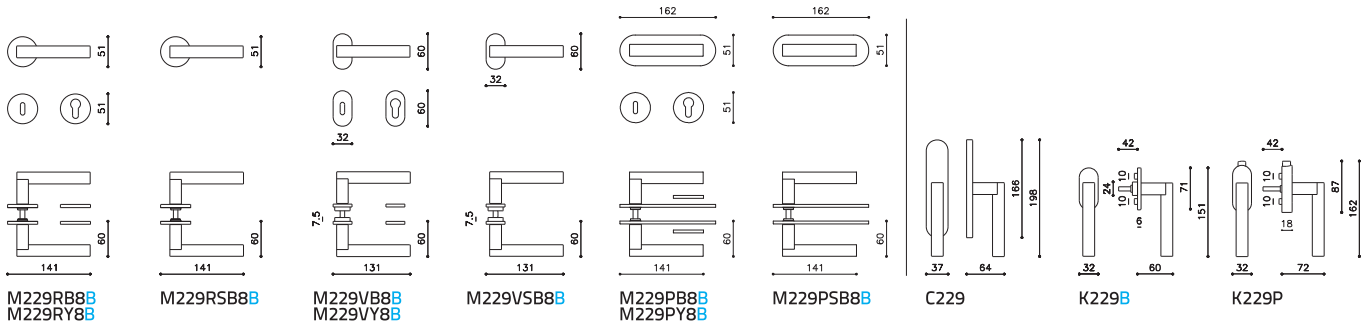

### Euclide Q M230 (p.45)

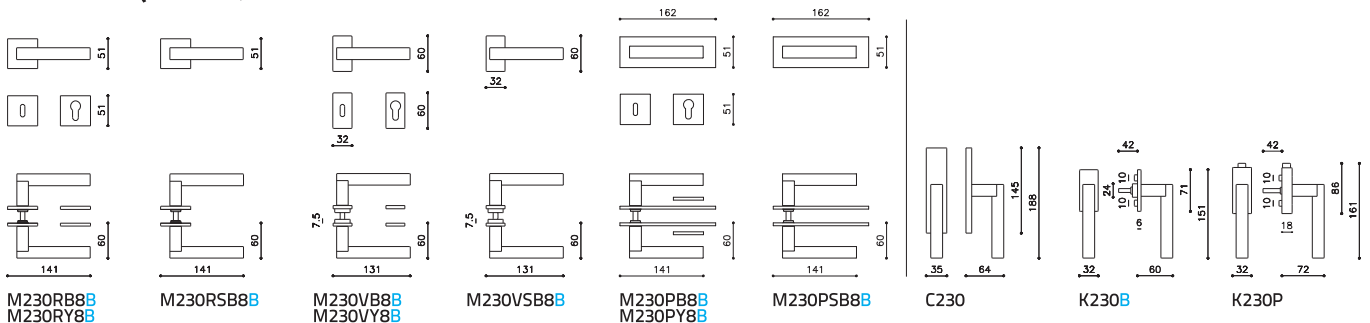

### Fin M217 (p.73)

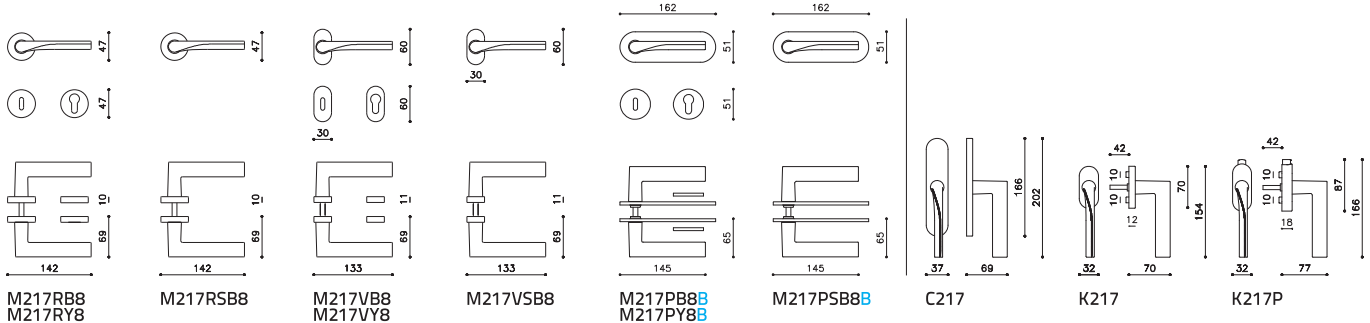

### Flaminia M159 (p.140)

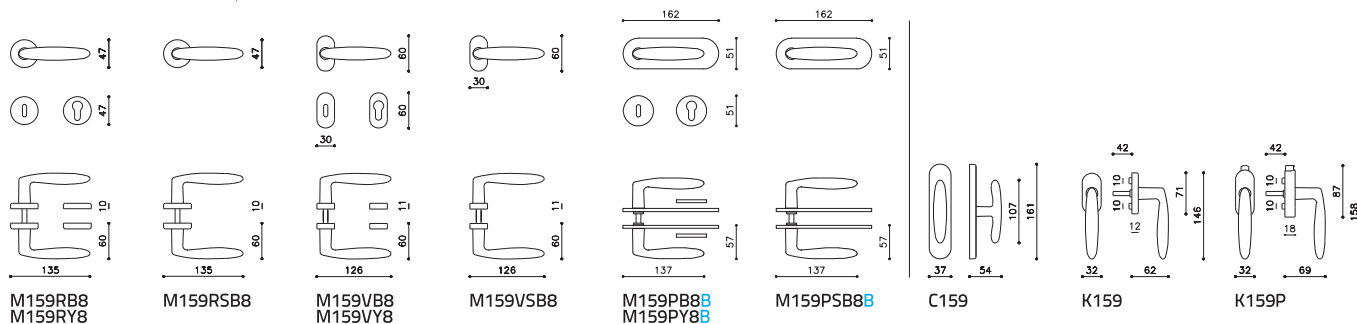

### Futura M172 (p.147)

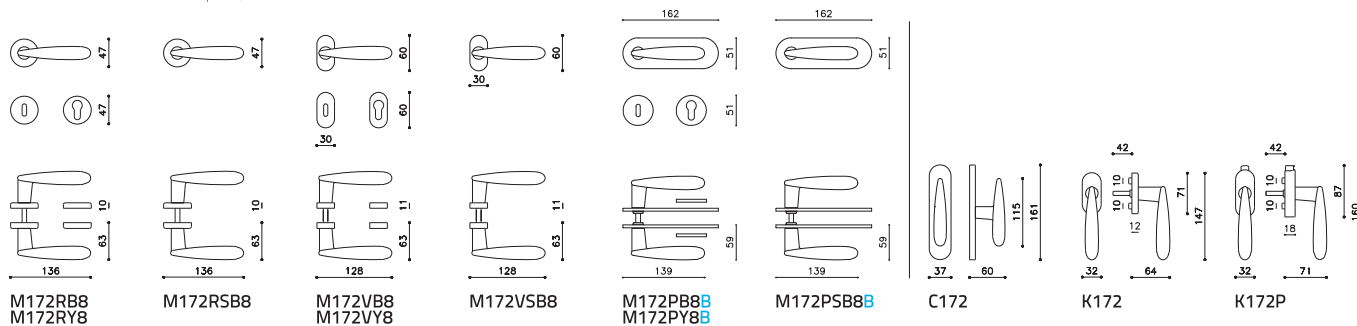

### Garda M105 (p.148)

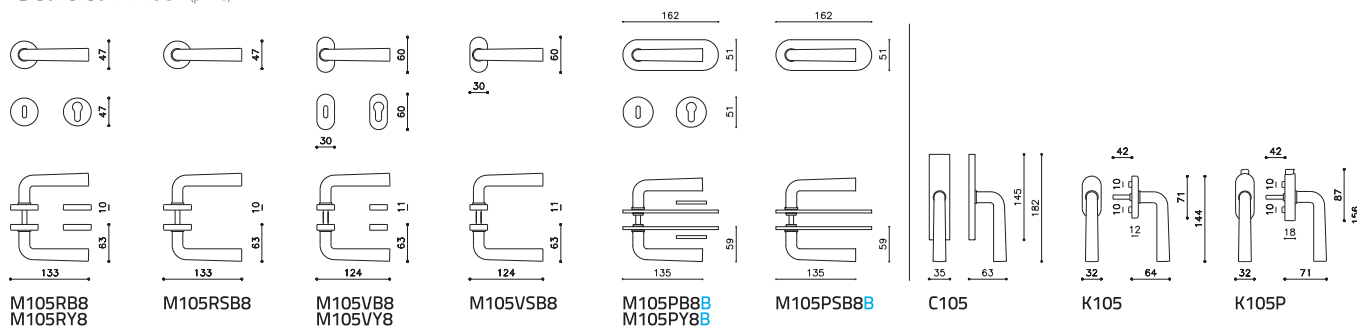

### Globe M227 (p.100)

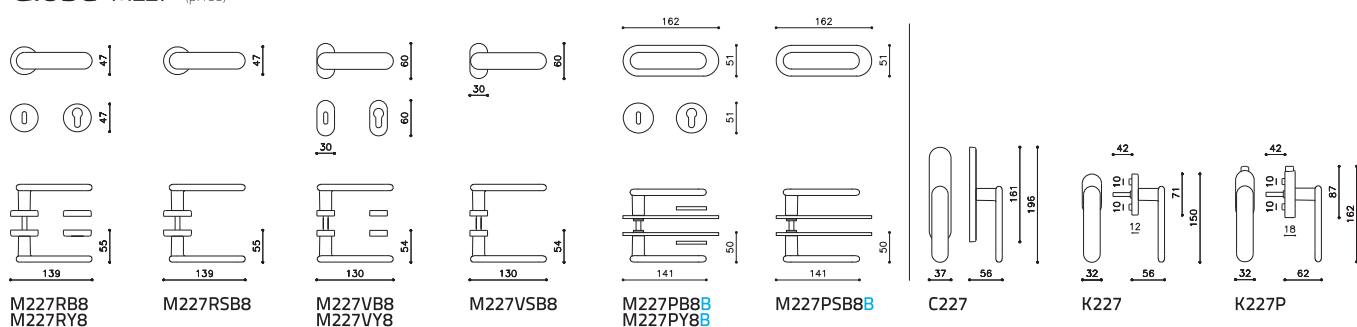

### Golia M160 (p.136)

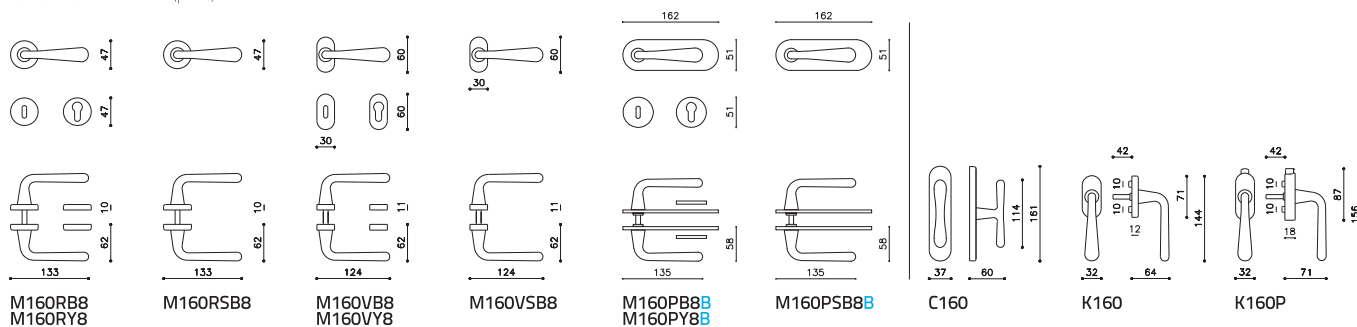

Icaro M168 (p.132)

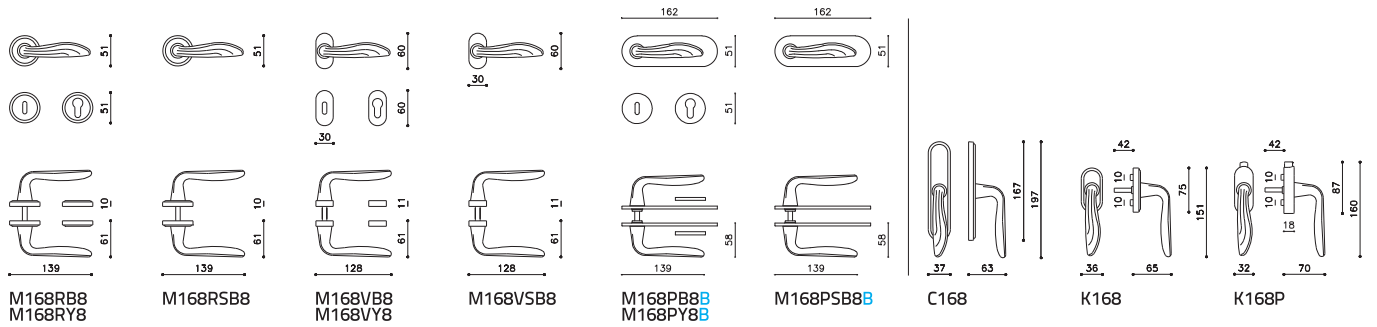

Ice Cube M223 (p.164)

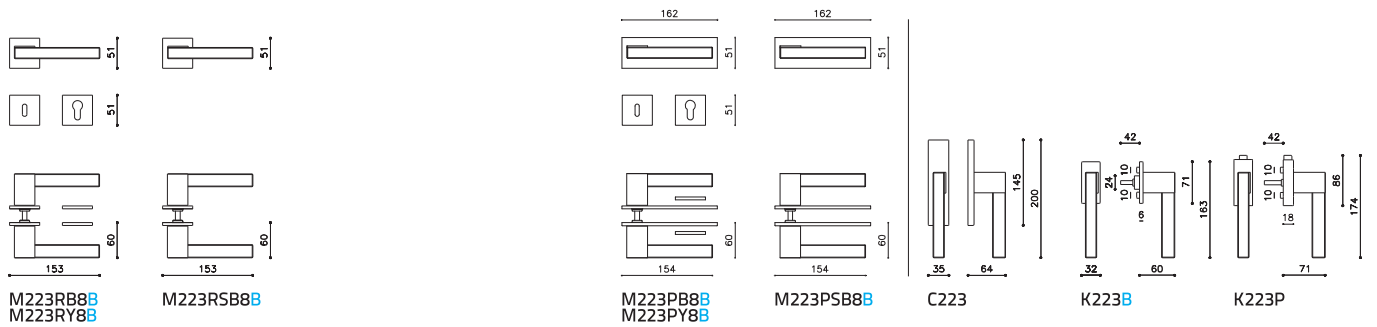

Icona M254 (p.94)

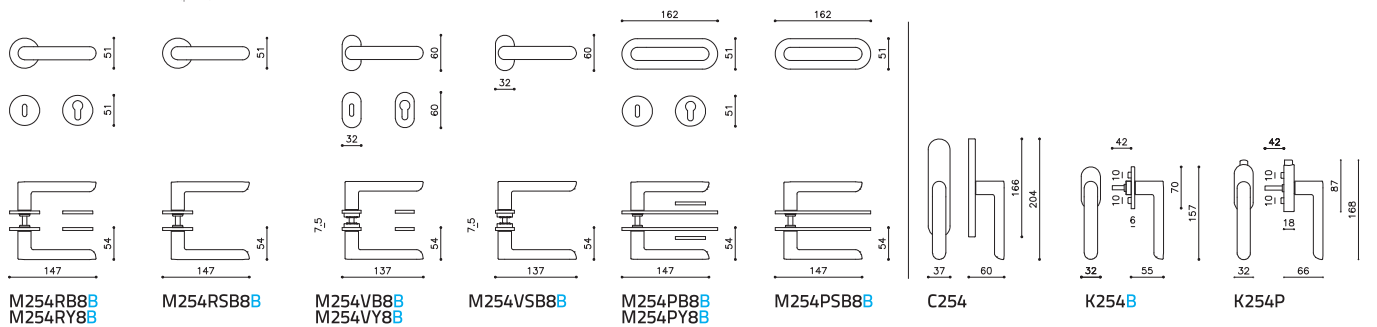

Iseo Ny M507 (p.178)

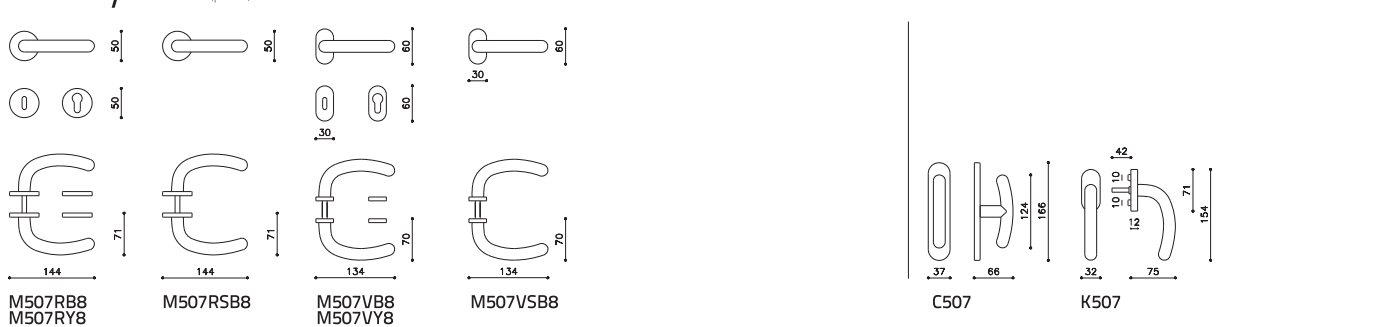

Lama M107 (p.72)

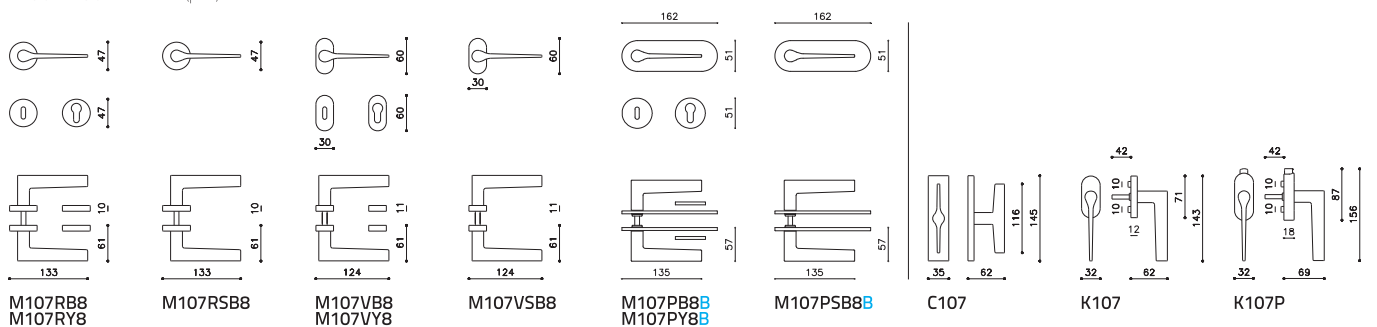



Lama L M106 (p.74)

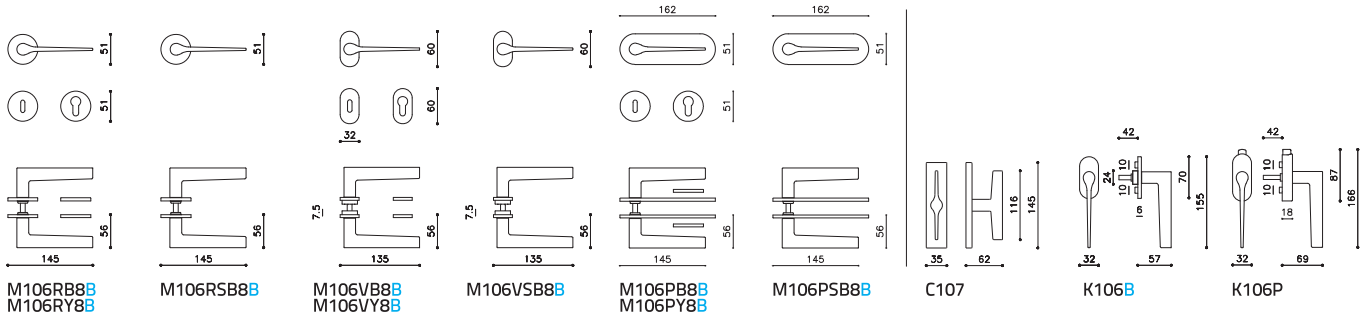

Laser M176 (p.104)

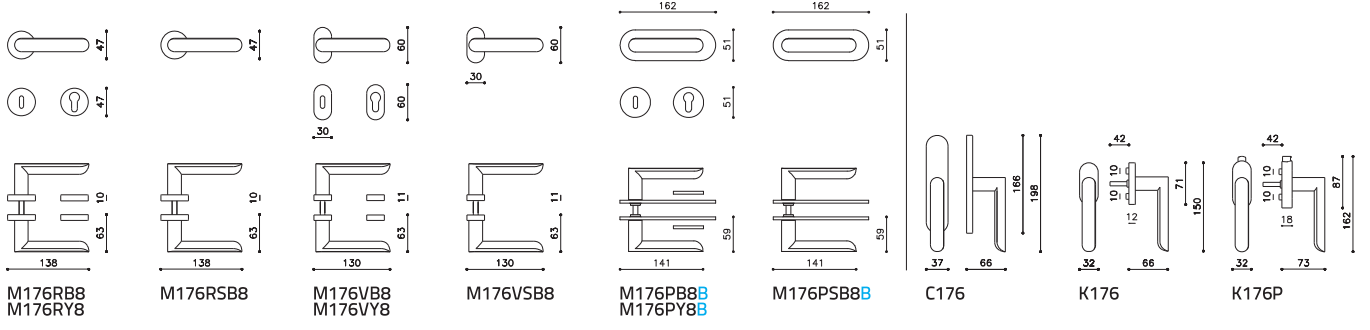

Lesmo M211 (p.24)

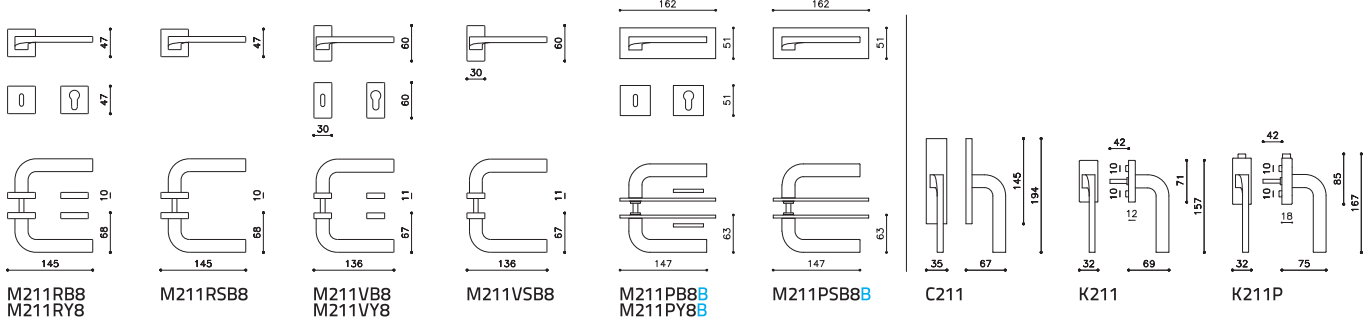

Link M200 (p.96)

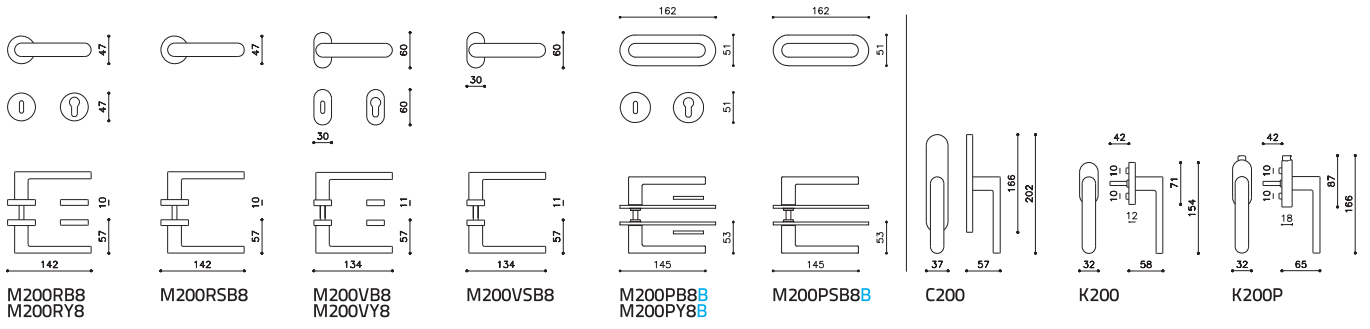

Living M222 (p.14)

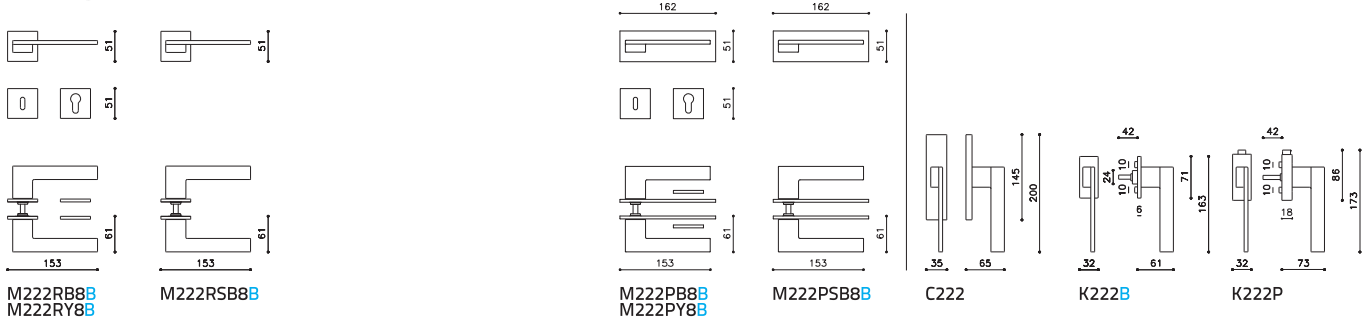

Logo M197 (p.98)

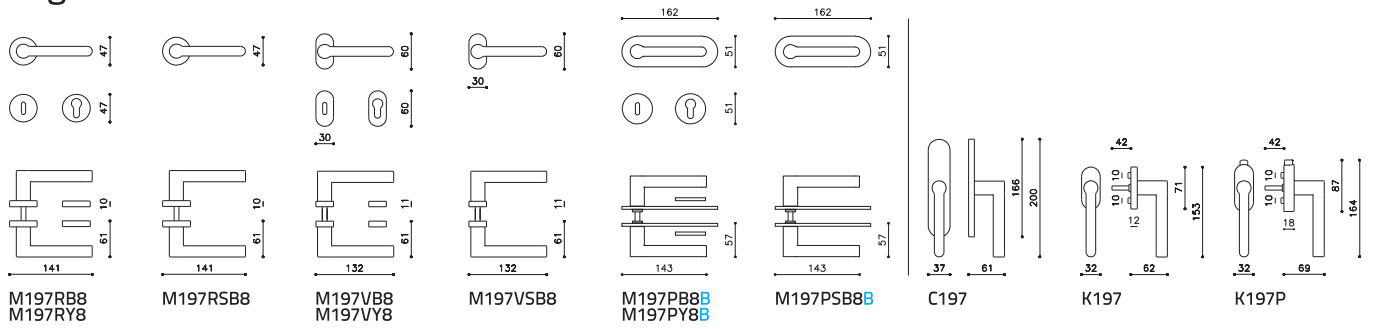

Lotus M238 (p.22)

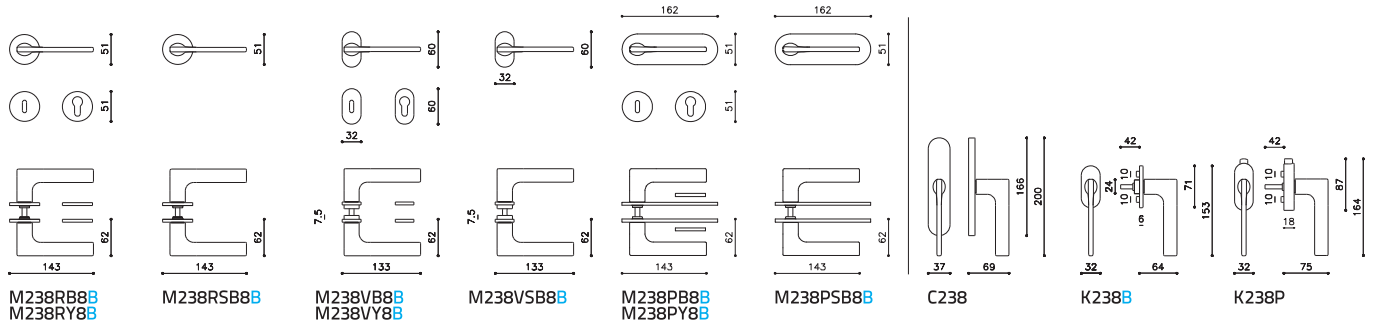

Lotus Q M241 (p.23)

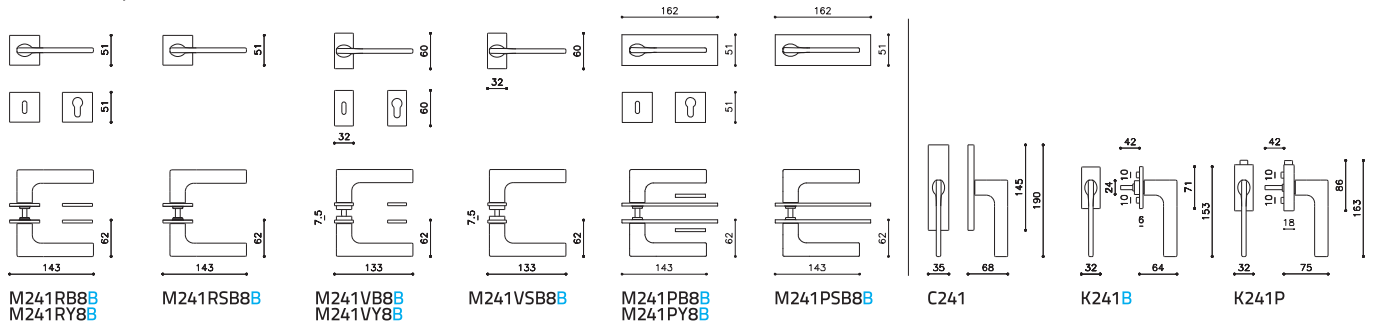

Lucy M231 (p.80)

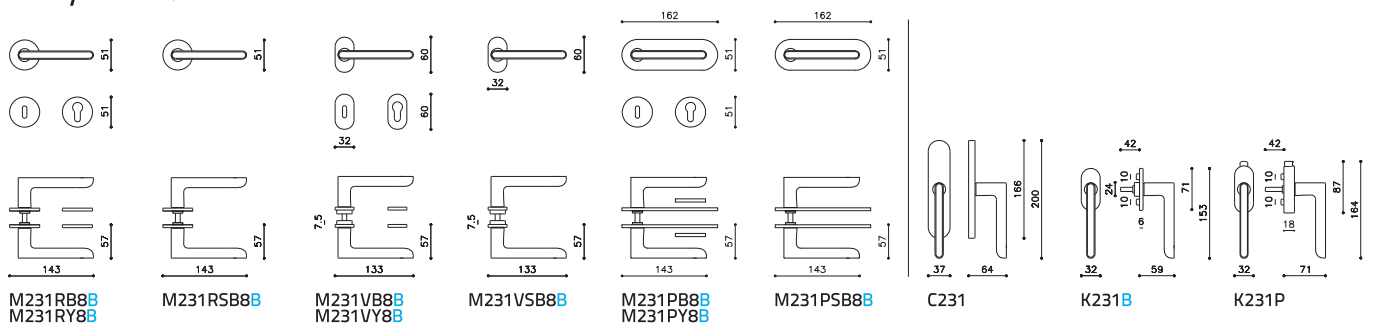

Lugano M258 (p.52)

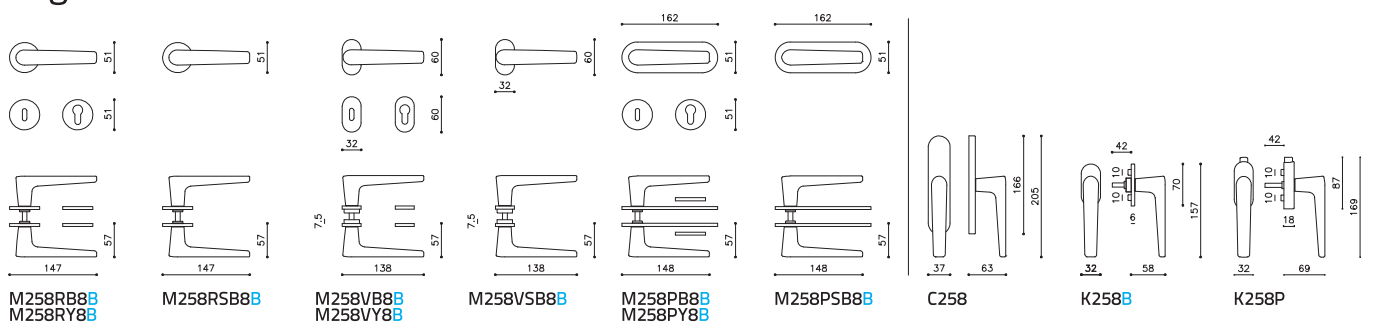

## Marbella M237 (p.62)

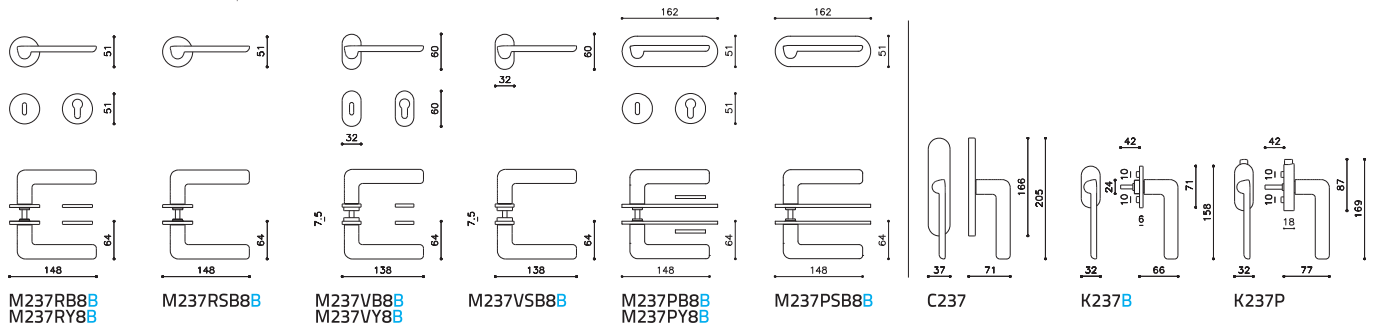

## Marilyn M252 (p.152)

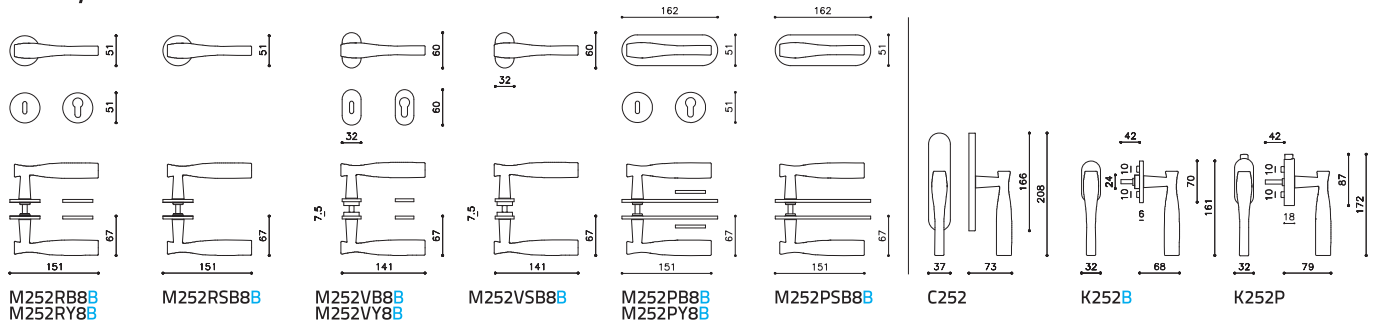

## Milano M259 (p.12)

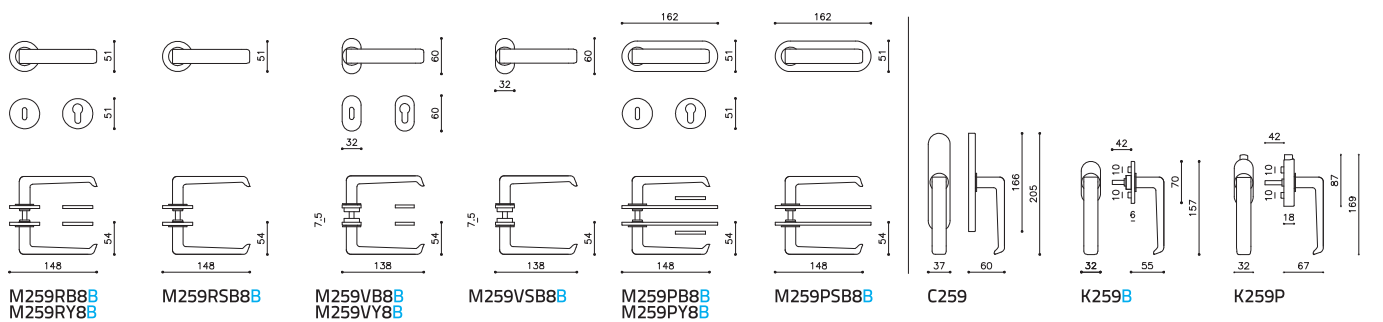

## Milano Q M260 (p.13)

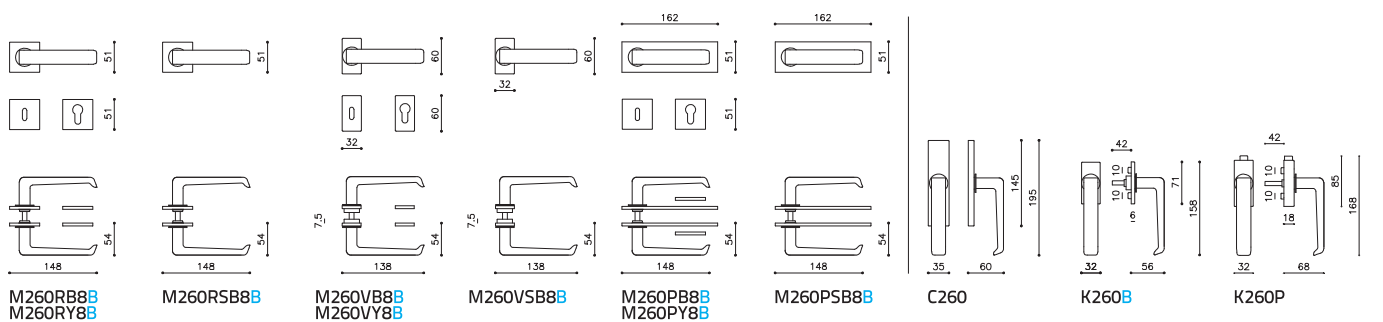

## Minerva M205 (p.34)

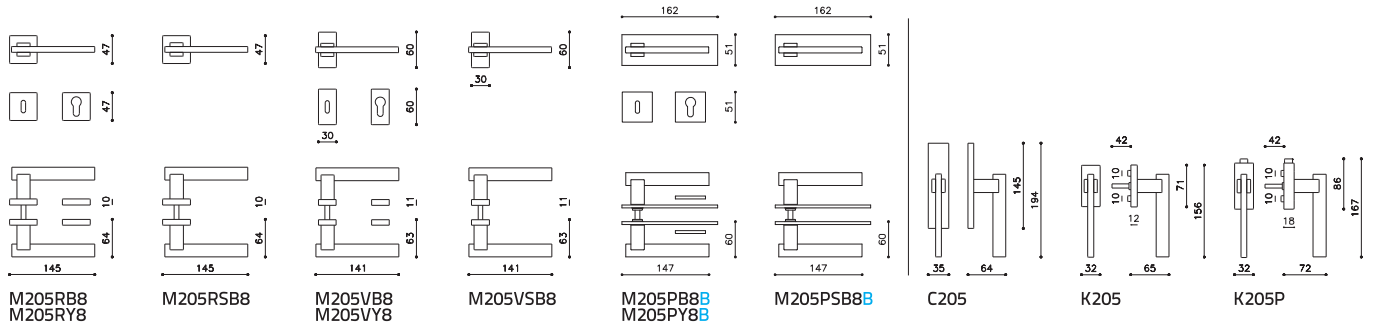



### Moon M226 (p.105)

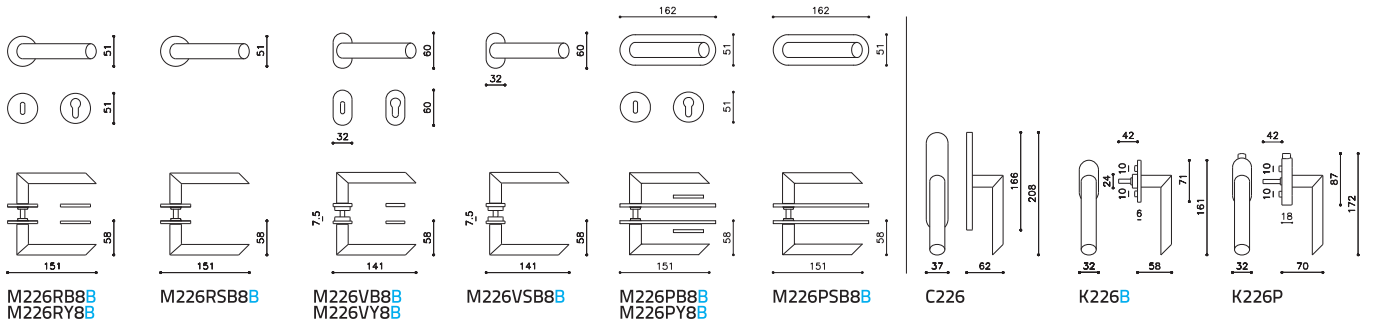

### Nina M234 (p.70)

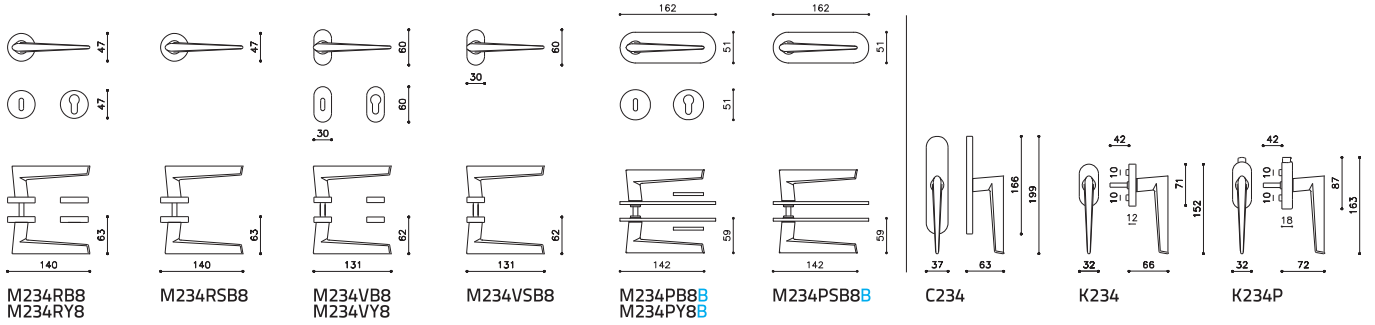

### Nirvana M173 (p.124)

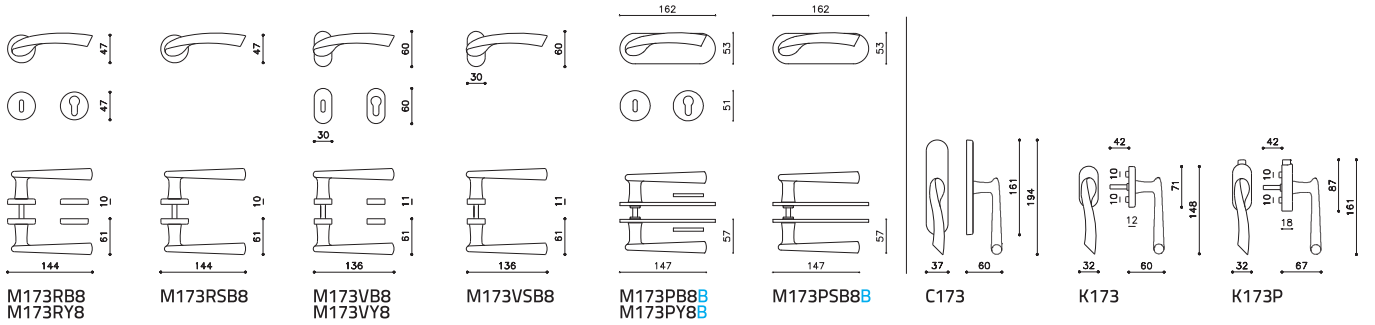

### Novella M165 (p.122)

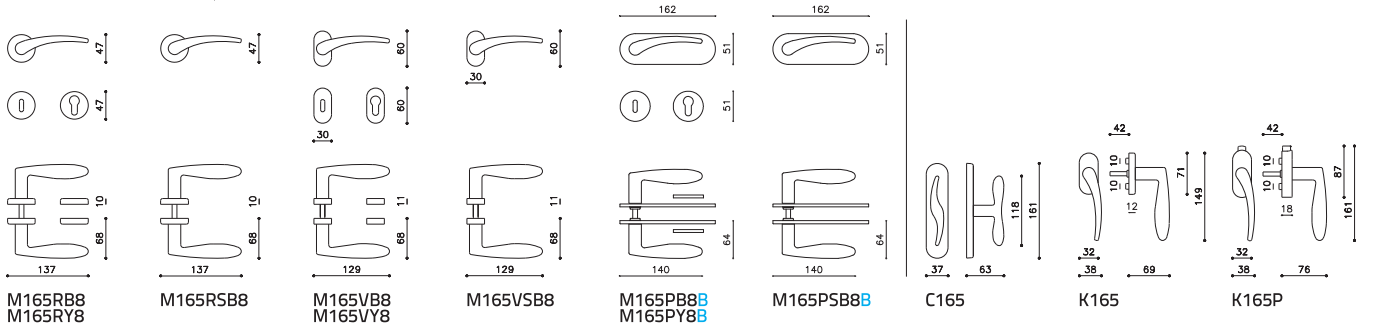

### Onda M175 (p.120)

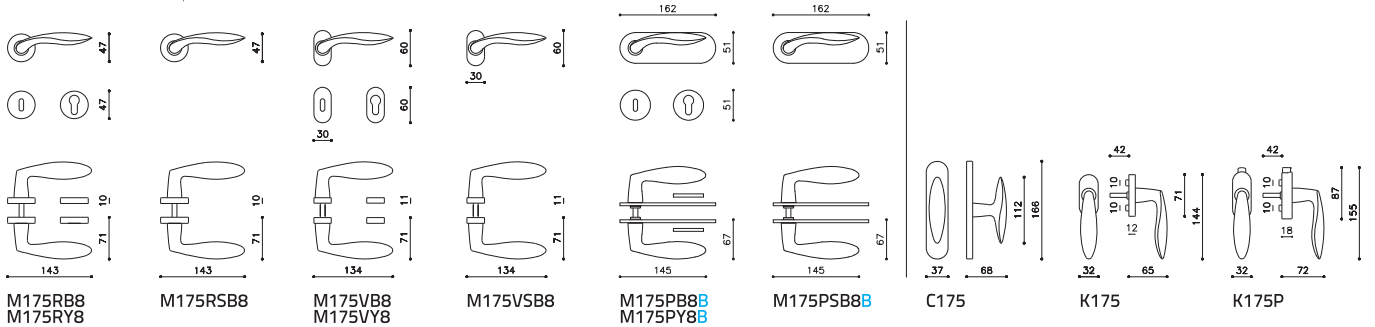

### Open M 249 (p.58)

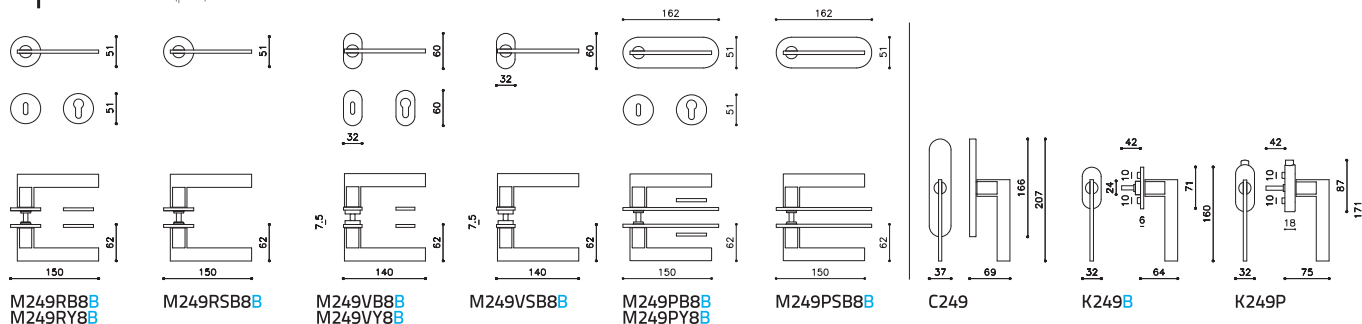

### Orvieto M170 (p.130)

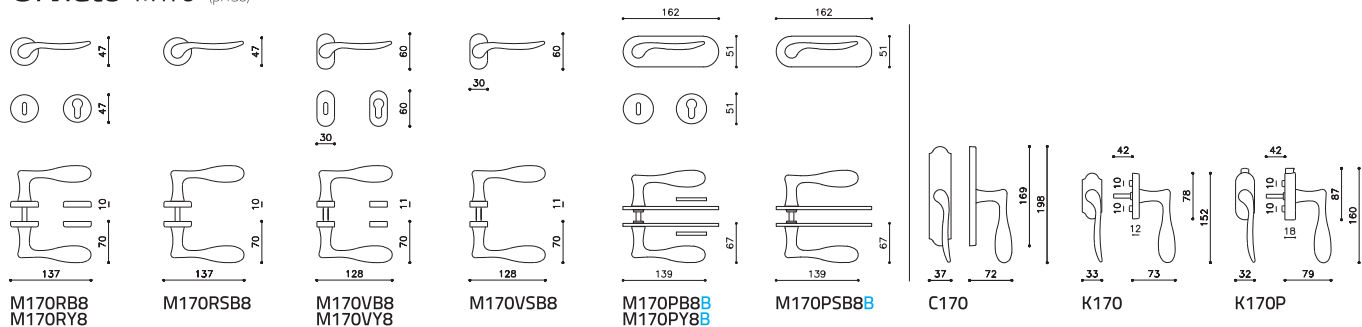

### Planet M195 (p.90)



### Planet bicolor M195 (p.90)



### Planet bassa M195 (p.90)

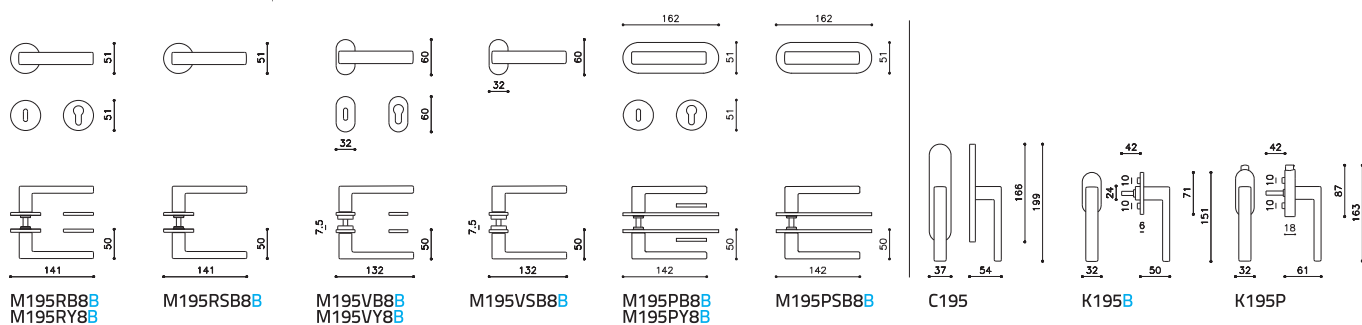

Planet bicolor bassa M195 (p.90)

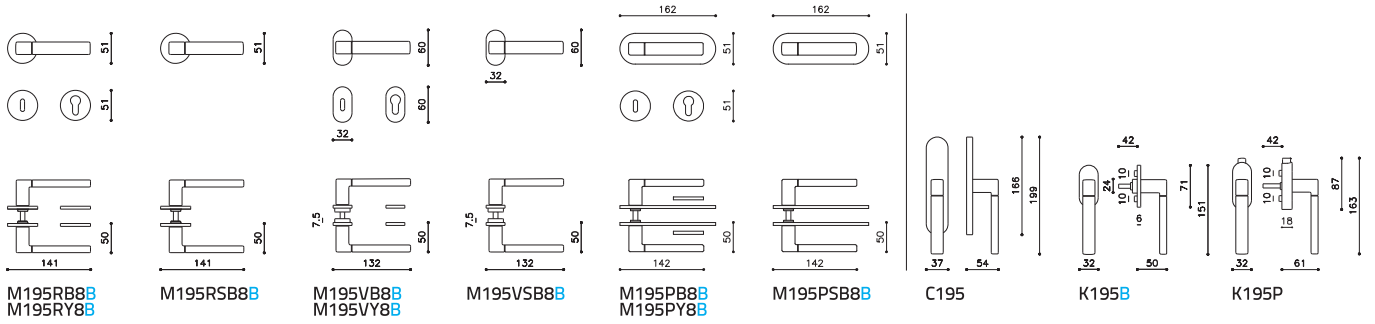

Planet Q M203 (p.42)



Planet Q bicolor M203 (p.42)



Planet Q bassa M203 (p.42)

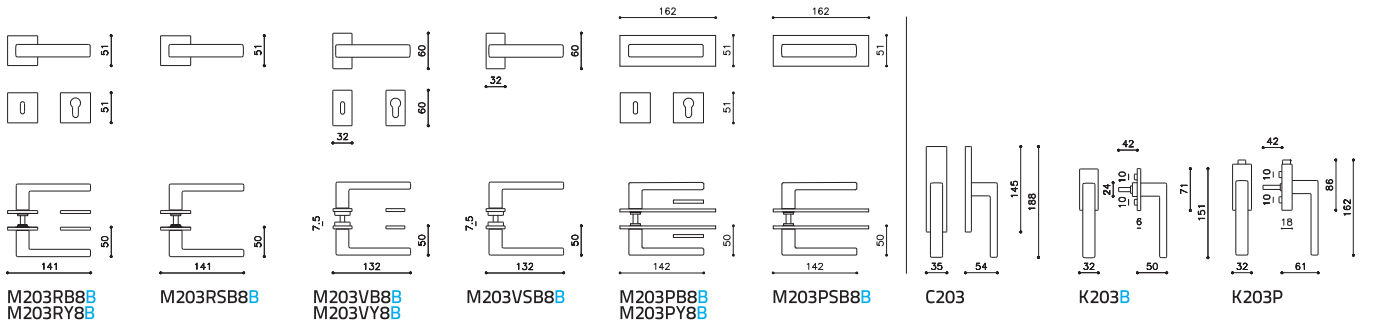

Planet Q bicolor bassa M203 (p.42)

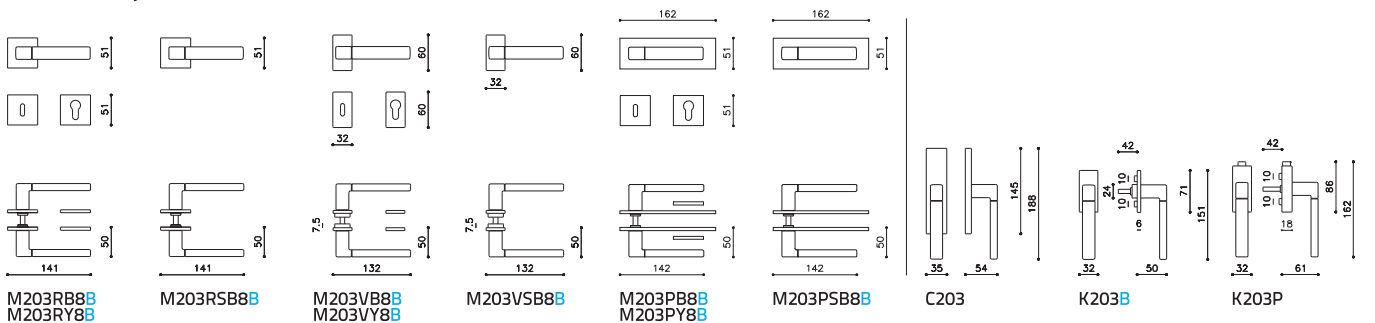



### Plume M 253 (p.64)

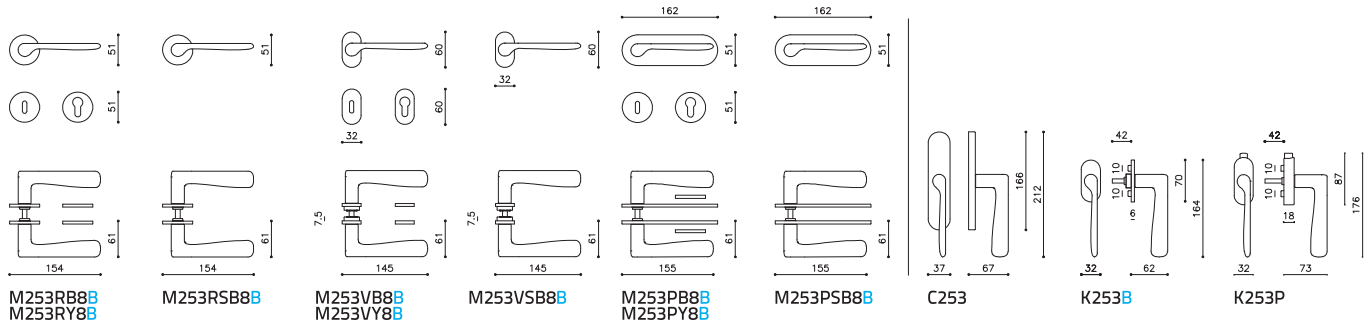

### Polo M152 (p.138)

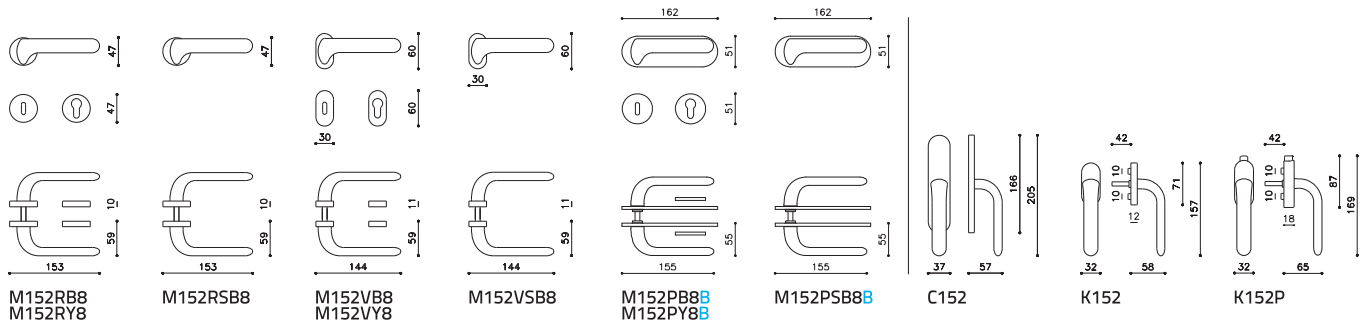

### Radial M235 (p.102)



### Raffaella M128 (p.112)

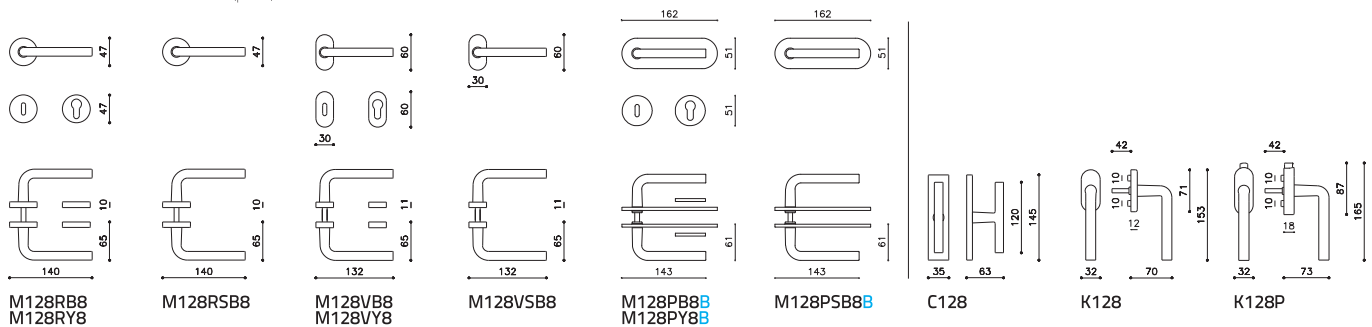

### Sector M186 (p.144)

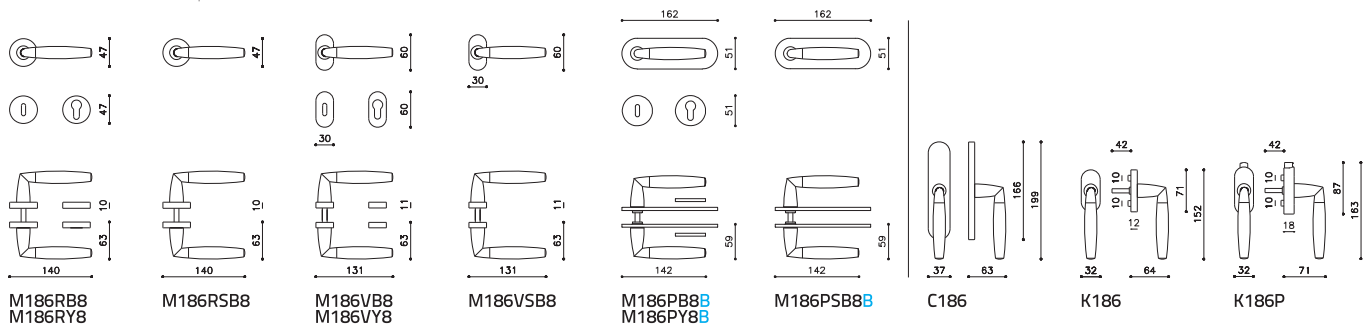

### Selene M194 (p.116)

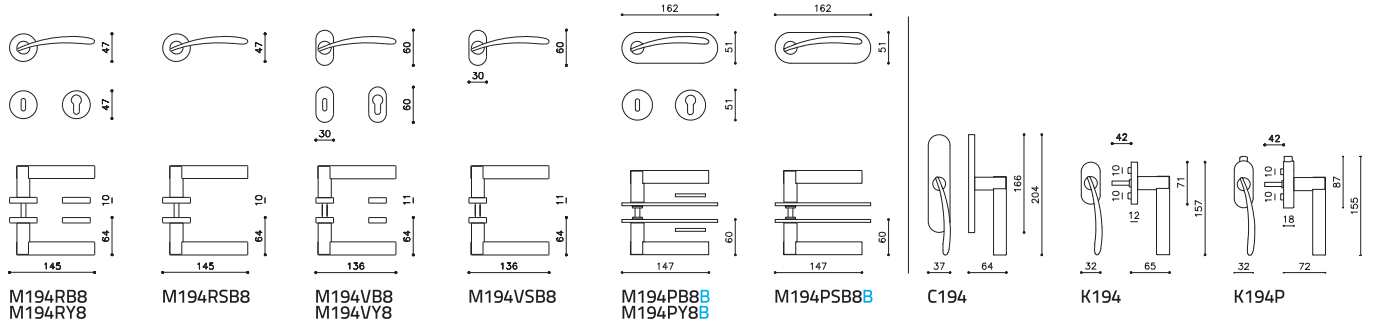

### Serenella M130 (p.110)

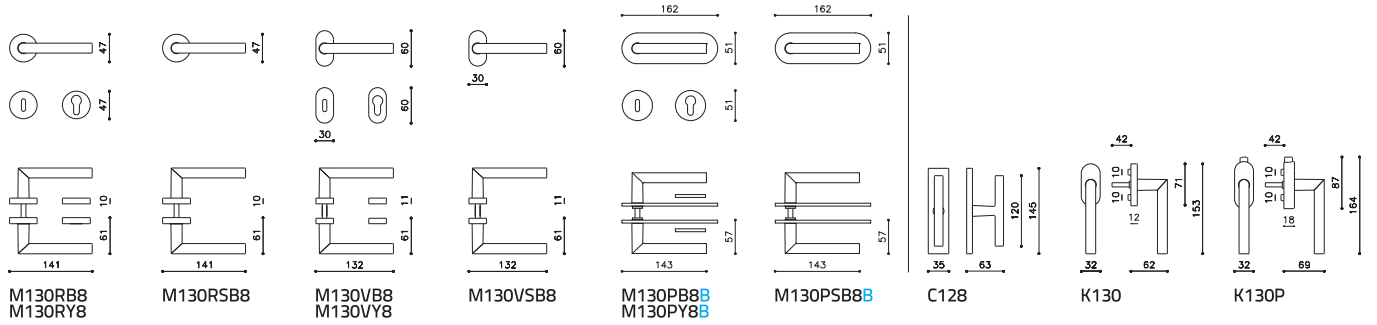

### Sibilla M154 (p.150)

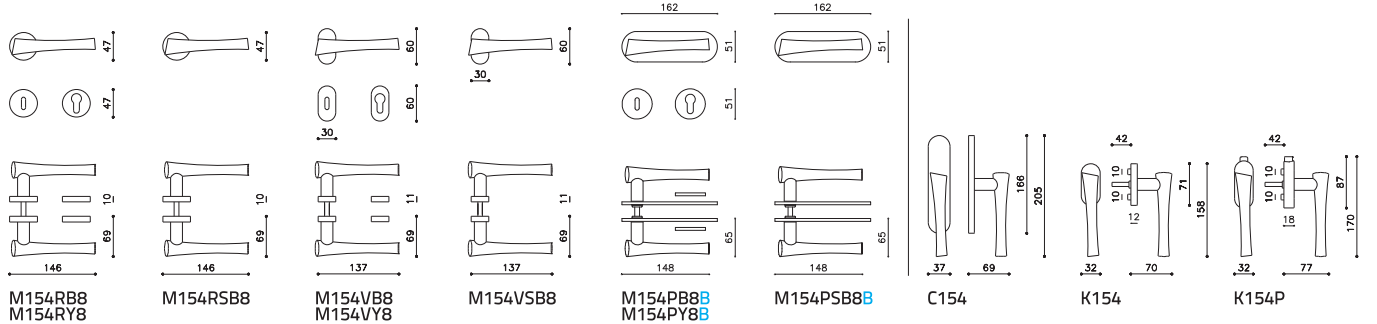

### Siena M169 (p.128)

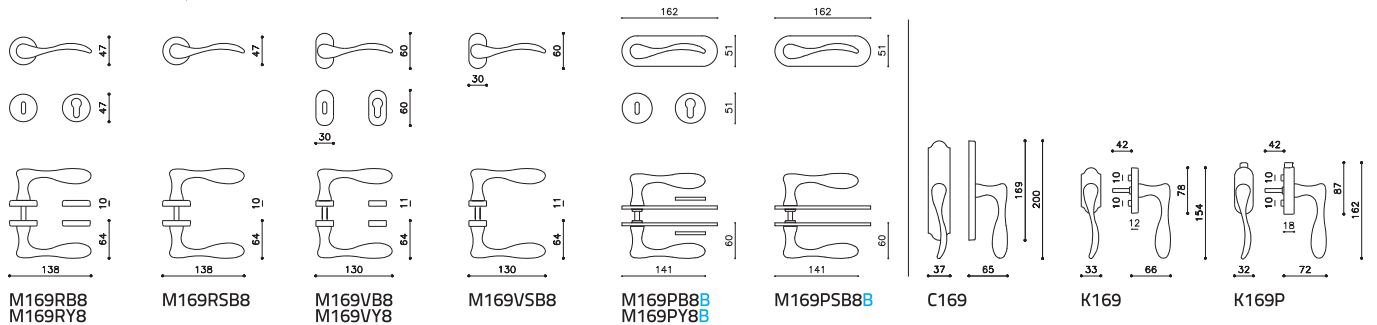

### Sky M214 (p.18)

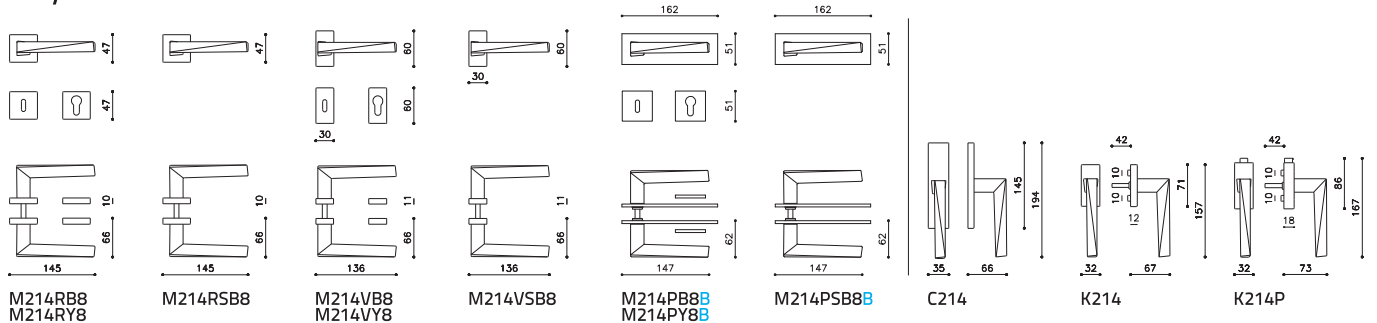

### Space M193 (p.32)

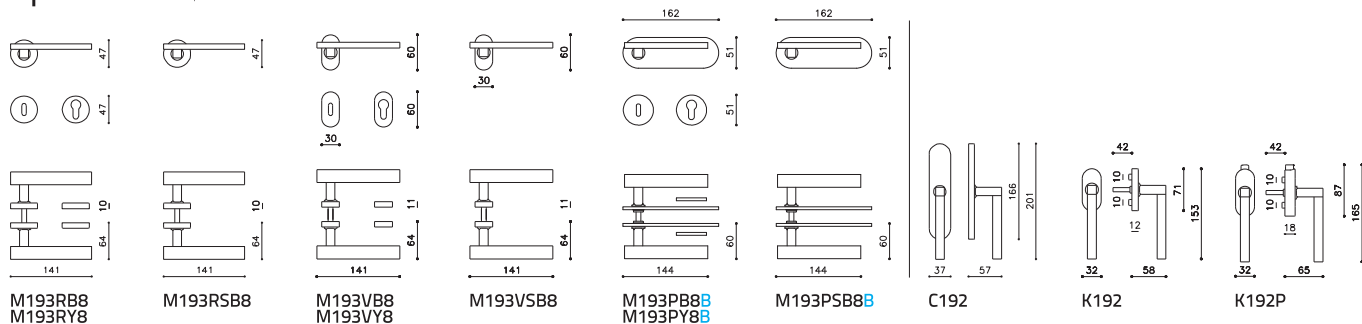

### Space Q M202 (p.33)

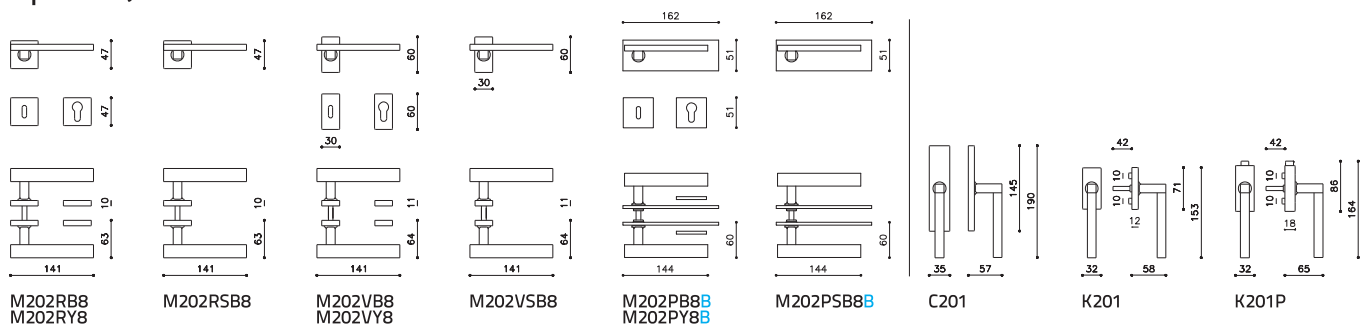

### Stilo M190 (p.84)

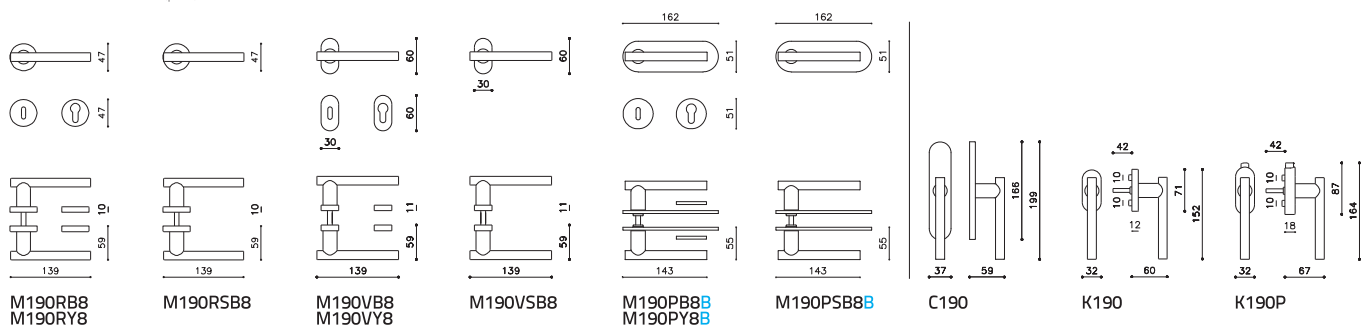

### Tecno M182 (p.68)

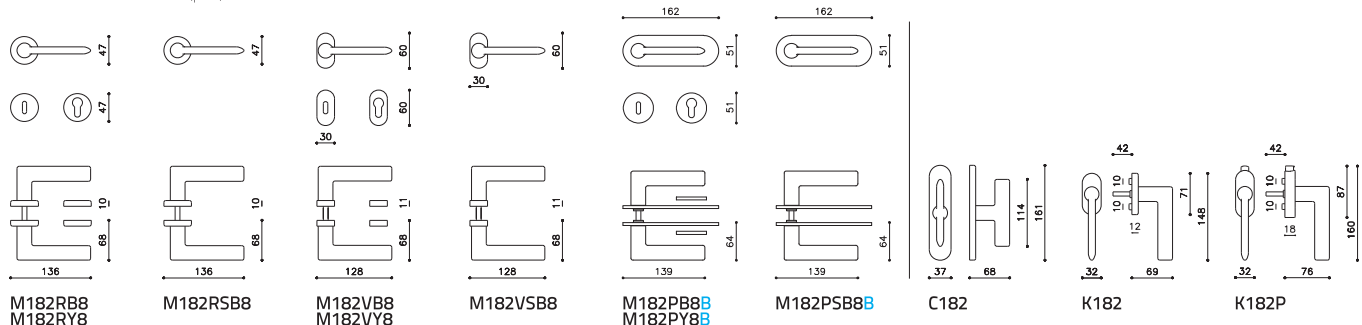

### Time M192 (p.30)

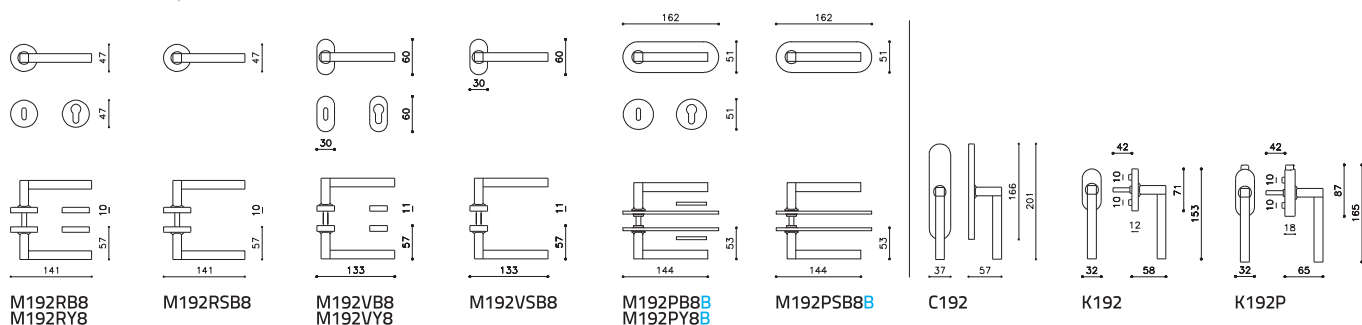



### Time Q M201 (p.31)

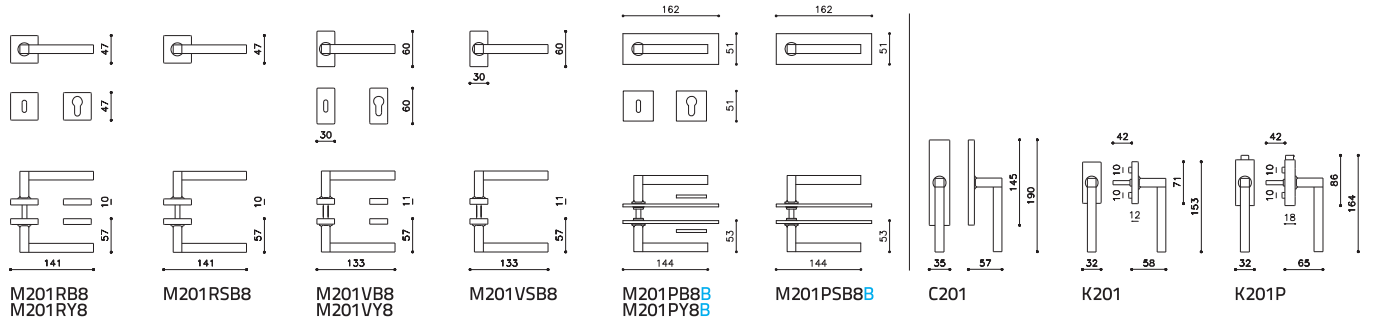

### Tizianella F M112 (p.108)

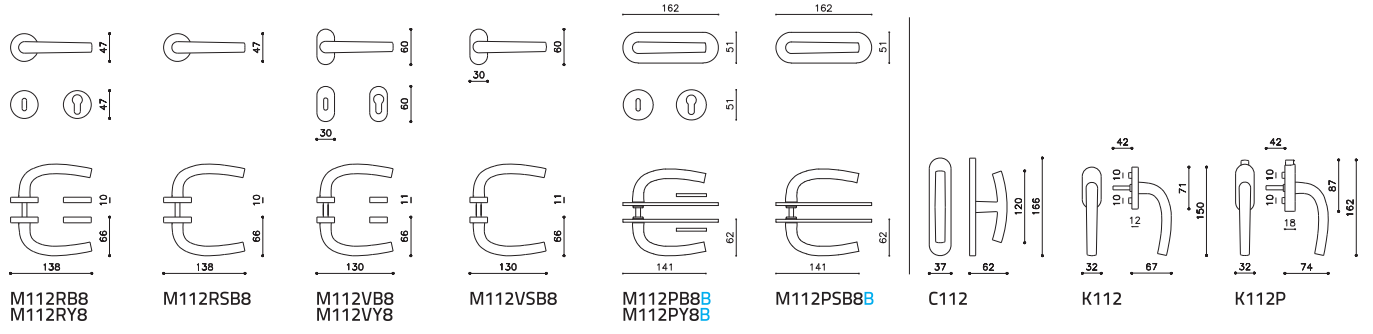

### Total M207 (p.46)



### Trend M228 (p.26)

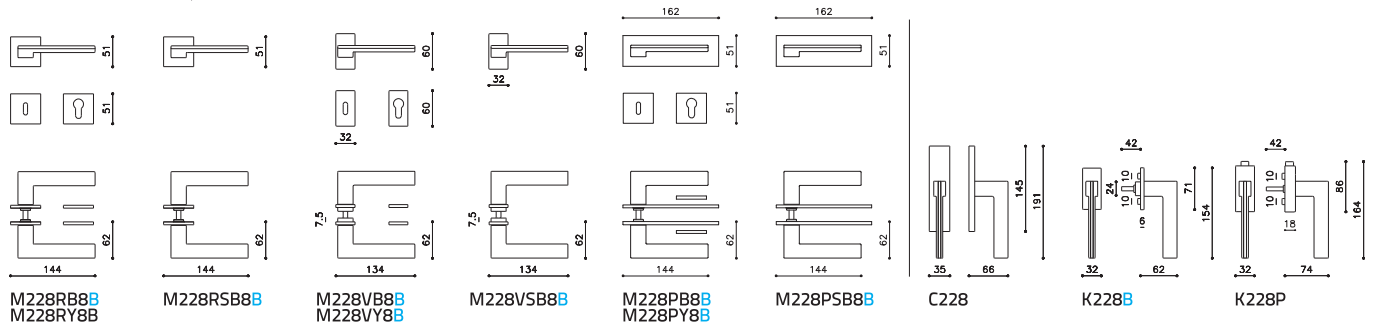

### Twist M242 (p.60)

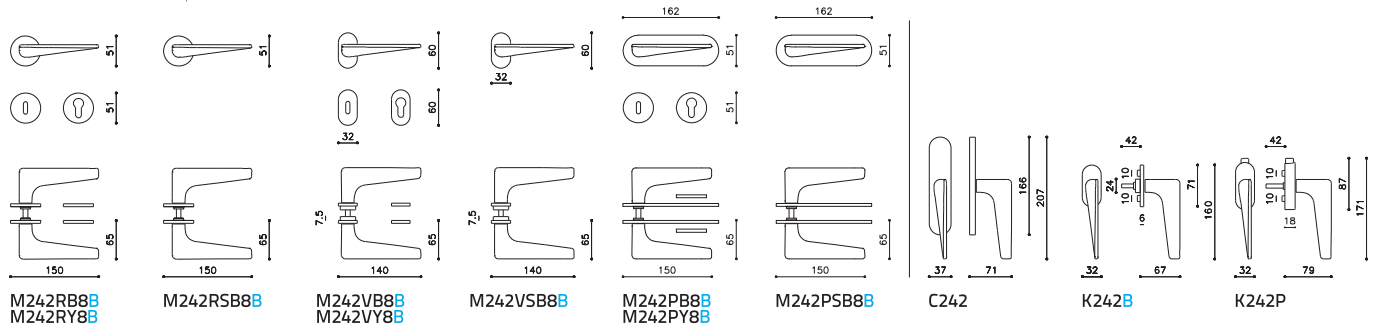

### Uovo M108 (p.156)

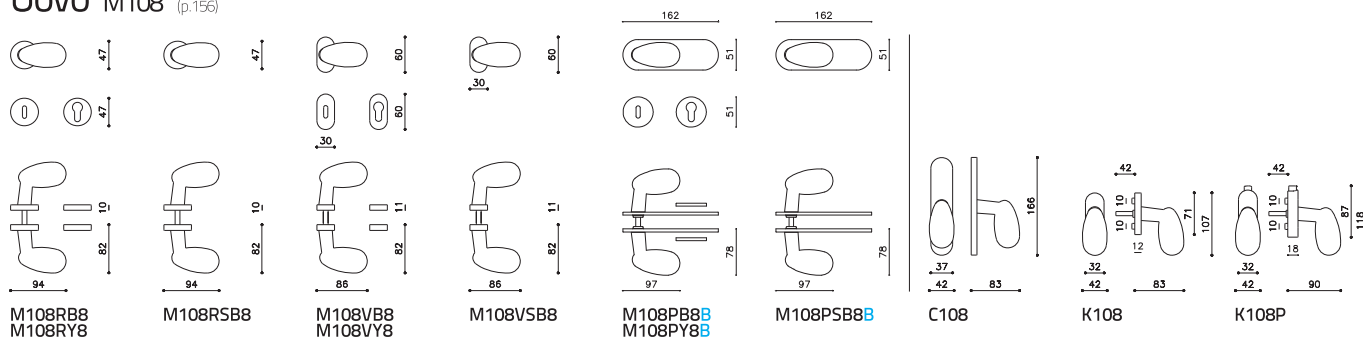

### Virgola M251 (p.82)

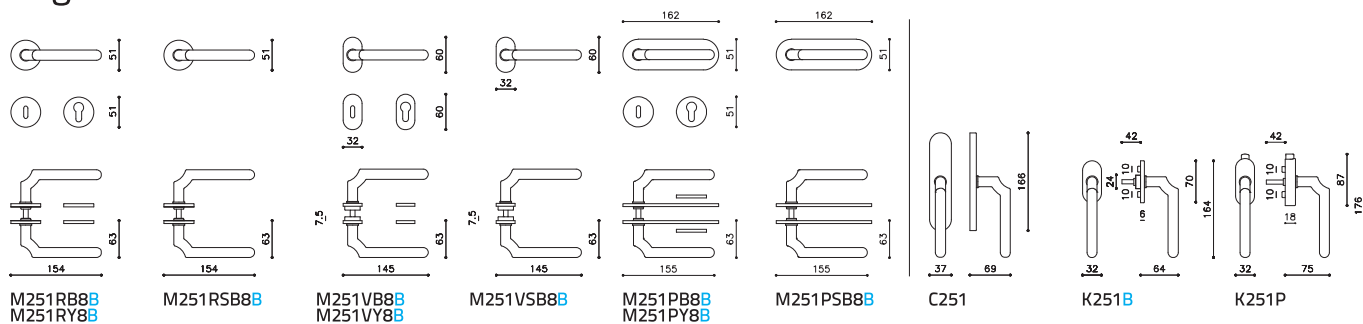

### Vola M257 (p.56)

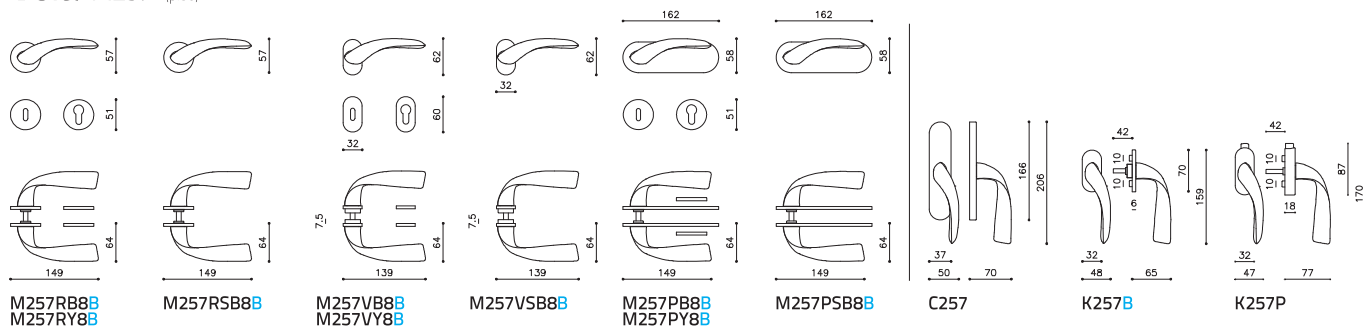

### Wind M187 (p.118)

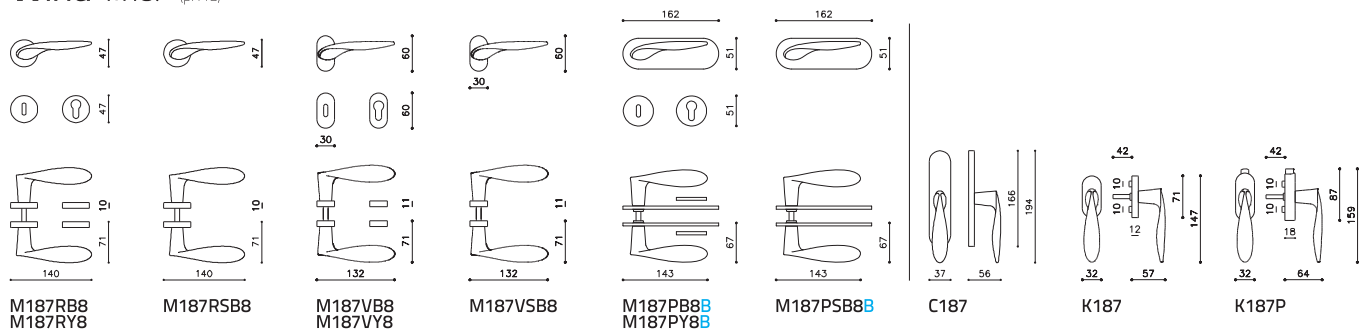





Il catalogo è soggetto ad aggiornamenti.

Ci riserviamo di apportare qualsiasi modifica ai prodotti e di eliminarli dalla produzione, senza obbligo di preavviso.

Dati, misure o schemi hanno solamente carattere informativo e non sono vincolanti.

Olivari declina qualsiasi responsabilità per eventuali refusi e/o errori presenti nel catalogo.

Tutti i diritti riservati © OLIVARI B. s.p.a.

I prodotti OLIVARI sono tutelati da brevetto in Europa e in molti paesi extra UE.

Al fine di evitare contraffazioni, marchiamo al laser tutte le maniglie sia con il logo OLIVARI sulla leva che con il codice identificativo del lotto e la data di produzione sul collarino. Questa marcatura indelebile, certifica che il prodotto è realizzato in ambito ISO 9001 e ne consente la tracciabilità. Invitiamo i clienti a diffidare da prodotti "tipo OLIVARI" e ad acquistare solo prodotti originali "OLIVARI".

We reserve the right to modify and discontinue any products, without prior notice.

Olivari declines all responsibility for any misprints and/or errors in the catalog.

All rights reserved © Olivari B. s.p.a.

OLIVARI products are registered and patented in Europe and many countries extra UE.

In order to avoid counterfeits, we laser-mark all the door handles both with the OLIVARI logo on the lever and with the identification code of the lot and the date of production on the neck. This indelible marking certifies that the product is made in ISO 9001 and allows traceability. We invite customers to beware of "OLIVARI type" products and to buy only "OLIVARI" original products.



### Concept and graphic

Marco Strina

### Photo

Laura Fantacuzzi & Maxime Galati

Alessandro Di Giugno

Leo Torri

BHM studio

Sauro Sorana

Ramak Fazel

Andrea Andreini

### Copy

Enrico Morteo

Francesca Picchi

### Translation

Wendy Wheatley

### Press Office

Ghenos\_Milano

### Pre press

Up studio\_Milano

### Printed in Italy

Galli Thierry stampa\_Milano 2020

### Thanks to

Matteo Brioni

Maurizio Patelli - Patedil

Cuoium

### Olivari B. spa

Via Giacomo Matteotti, 140  
28021 Borgomanero NO Italy

T +39 0322 835080

F +39 0322 846484

olivari@olivari.it

www.olivari.it

Questo catalogo è stato stampato su carta Sappi Magno Satin certificata FSC, prodotta con cellulosa proveniente da foreste gestite in maniera responsabile. L'energia necessaria per la stampa è stata prodotta da un impianto fotovoltaico. Il contributo all'ambiente è il seguente: CO<sub>2</sub> non immessa in atmosfera 79.645 kg/year, petrolio risparmiato 42.063 l/year, alberi equivalenti 159 trees/year.

This catalog was printed on paper Sappi Magno Satin FSC certified, produced with cellulose coming from responsibly managed forests. The energy for printing was totally produced by a photovoltaic system. The contribution to the environment is the following: CO<sub>2</sub> not released into the atmosphere 79.645 kg / year, oil saved 42.063 l / year, trees equivalent 159 trees/ year.





olivari.it