



catalogo generale

general catalog



Indice generale



MANIGLIE SU ROSETTA QUADRA



766
Spigola
pag. 24



766B
Spigola B
pag. 25



767
Composita
pag. 28



768
Toga
pag. 27



769
Cuba
pag. 28



769B
Cuba B
pag. 29



770
Milano
pag. 30



771
Monza
pag. 31



812
Crystal
pag. 32



813
Shine
pag. 33



1127
Nuvola
pag. 34



1127B
Nuvola B
pag. 35



1129
Arianna
pag. 36



1130
Kioto
pag. 37



2105
Lotus
pag. 38



2106
Trix
pag. 39



2107
Square
pag. 40



2108
Zonta
pag. 41



2109
Honey
pag. 42



2110B
Luxury B
pag. 43



2111B
Prestige B
pag. 44



2112
Space
pag. 45



2147
Linzi
pag. 46



MANIGLIE SU ROSETTA SLIM



769
Cuba
pag. 50



769B
Cuba B
pag. 51



1127
Nuvola
pag. 52



1127B
Nuvola B
pag. 53



2109
Honey
pag. 54

Indice generale



2113
Tesa
pag. 55



2110B
Luxury B
pag. 67



2270B
Paris B
pag. 77



2114
Nives
pag. 56



2111B
Prestige B
pag. 68



2271B
Scarlet B
pag. 78



**MANIGLIE
SU ROSETTA
TONDA
PREMONTATA**



2112
Space
pag. 69



2274B
Star B
pag. 79



766
Spigola
pag. 60



2113
Tesa
pag. 70



2275B
Adria B
pag. 80



766B
Spigola B
pag. 61



2114
Nives
pag. 71



**MANIGLIE
SU ROSETTA
TONDA**



1130
Kioto
pag. 62



2130
Marea
pag. 72



148
Miriam
pag. 84



1770
Ginevra
pag. 63



2130B
Marea B
pag. 73



148B
Miriam B
pag. 85



1776
Ottocento
pag. 64



2140
Meganisi
pag. 74



150
Adry
pag. 86



1777
Firenze
pag. 65



2147
Linzi
pag. 75



151
Modial
pag. 87



2109
Honey
pag. 66



2260
Sirio
pag. 76



160
Bastone
pag. 88

Indice generale



160P
Bastone Pes.
pag. 89



370
Chiara
pag. 90



380
Cometa
pag. 91



450
Elisa
pag. 92



450B
Elisa B
pag. 93



580
Epoca
pag. 94



580B
Epoca B
pag. 95



690
Opera
pag. 96



691
Futura
pag. 97



755
Antea
pag. 98



755B
Antea B
pag. 99



765
Minerva
pag. 100



765B
Minerva B
pag. 101



769
Cuba
pag. 102



769B
Cuba B
pag. 103



1050
Onda
pag. 104



1055
Ines
pag. 105



1060
Alfa
pag. 106



1060B
Alfa B
pag. 107



1062B
Luna B
pag. 108



1110
Giada
pag. 109



1125
Rugiada
pag. 110



1126
Sidney
pag. 111



1127
Nuvola
pag. 112



1127B
Nuvola B
pag. 113



1128
Asia
pag. 114



1129
Arianna
pag. 115



1260
Uovo
pag. 116

































1775
Aurelia
pag. 117



1778
Torino
pag. 118

Indice generale

 1779 Viareggio <i>pag. 119</i>	 MANIGLIONI <i>pag. 130</i>	 ACCESSORI PER SCORREVOLI <i>pag. 296</i>
 1790 Sofia <i>pag. 120</i>	 MAN. ALZANTI SCORREVOLI <i>pag. 176</i>	 NICCHIE PER SCORREVOLI <i>pag. 302</i>
 1791 Diamantea <i>pag. 121</i>	 POMOLI FISSI <i>pag. 194</i>	 NOTTOLINI WC <i>pag. 320</i>
 1792 Camelia <i>pag. 122</i>	 POMOLI A COPPIA <i>pag. 206</i>	 COORDINATI <i>pag. 334</i>
 1793 Scalea <i>pag. 123</i>	 BATTENTI <i>pag. 214</i>	 ACCESSORI <i>pag. 356</i>
 179 CB collo basso <i>pag. 124</i>	 SICUREZZA HOTEL <i>pag. 220</i>	 MARCHIATURA <i>pag. 371</i>
 164 Anello salva muro <i>pag. 125</i>	 SUPPORTI <i>pag. 238</i>	 BLISTER <i>pag. 372</i>
 161 Ovalino MP <i>pag. 126</i>	 KIT SCORREVOLI OVALI e RETT. <i>pag. 250</i>	 ESPOSITORI <i>pag. 374</i>
 161T Ovalino MP <i>pag. 127</i>	 KIT SCORREVOLI TONDI <i>pag. 272</i>	 CONFEZIONI <i>pag. 376</i>
 163 Ovalino R <i>pag. 128</i>	 KIT SCORREVOLI QUADRI <i>pag. 288</i>	 INDICE NUMERICO <i>pag. 378</i>

Azienda

Company



Da una piccola azienda artigiana acquistata dal gruppo Laffranchi nell'anno 2000 nasce la Mariva srl. Grazie ad una consolidata esperienza quarantennale nel campo dell'ottone, il gruppo Laffranchi, decide di differenziare il proprio prodotto, entrando di fatto nel settore produttivo delle maniglie e coordinati in ottone. La filosofia aziendale è basata, oltre alla qualità e continuo studio di design e progettazione dei propri articoli, anche sull'efficienza del servizio al cliente, ottimizzando gli ordini on-time e i tempi di set-up, seguendo una filosofia just in time. In questo modo Mariva srl riesce a creare un servizio al cliente di elevata qualità sia per quanto riguarda la puntualità che la rapidità nella consegna della merce, fattori di notevole importanza in un mondo sempre più veloce ed imprevedibile.

From a small company acquired by the Group Laffranchi, Mariva srl was born in 2000. Thanks to a well-established forty years experience in the field of brass, the group Laffranchi, decided to differentiate their product, in fact entering into the productive sector of the handles and matching brass. The company philosophy is based, in addition to quality and continuous study of design of their products, even the efficiency of customer service, optimizing orders on-time and time to set-up, according to a just-in-time philosophy. In this way Mariva srl fails to create a customer service of high quality both in terms of punctuality that the rapidity in the delivery of goods, factors of considerable importance in a world increasingly fast and unpredictable.

Laffranchi group

Laffranchi group



Laffranchi group, grazie alle due aziende del gruppo, riesce ad ottenere una gamma di accessori tra le più complete sul mercato, i prodotti variano dagli accessori per porte ed infissi di Mariva alle cerniere e pomolini per mobili di Elab. Lo sviluppo delle tecnologie e la continua ricerca di nuovi prodotti permettono al gruppo di ottenere un catalogo completo dove trovare soluzioni tecniche e di design, i due settori vengono divisi tra le due aziende, Mariva per il settore porte ed infissi ed Elab per il settore mobili ed accessori.

Laffranchi group, thanks the two companies in the group manages to obtain a range of accessories brass of the most complete available on the market, products ranging from accessories for doors and windows of Mariva to hinges and pomolini for furniture Elab. The development of technologies and the continuing search for new products allow the group to obtain a complete catalogue where to find technical solutions and design, the two areas are divided into two companies, Mariva for the door handles and Elab for the furniture and accessories.

Archilab Mariva

Archilab Mariva



Archilab Mariva propone un'iniziativa finalizzata alla selezione di progetti innovativi per quanto riguarda pomoli, maniglie, maniglioni, maniglie ad incasso e complementi. Lo scopo è quindi quello di promuovere la progettazione e realizzazione di nuovi modelli ad elevato valore innovativo dal punto di vista funzionale e del design. Per qualsiasi proposta, innovazione e possibile collaborazione vi invitiamo a scrivere alla casella mail:

archilab@marivasrl.com

Archilab Mariva proposes an initiative aimed at selecting innovative projects with regard to knobs, handles, pull handles, recessed handles and complements. The aim is therefore to promote the design and implementation of new models of high value in terms of innovative and functional design. For any proposal, and innovation can collaboration we invite you to write to the mail box:

archilab@marivasrl.com

Design

Design

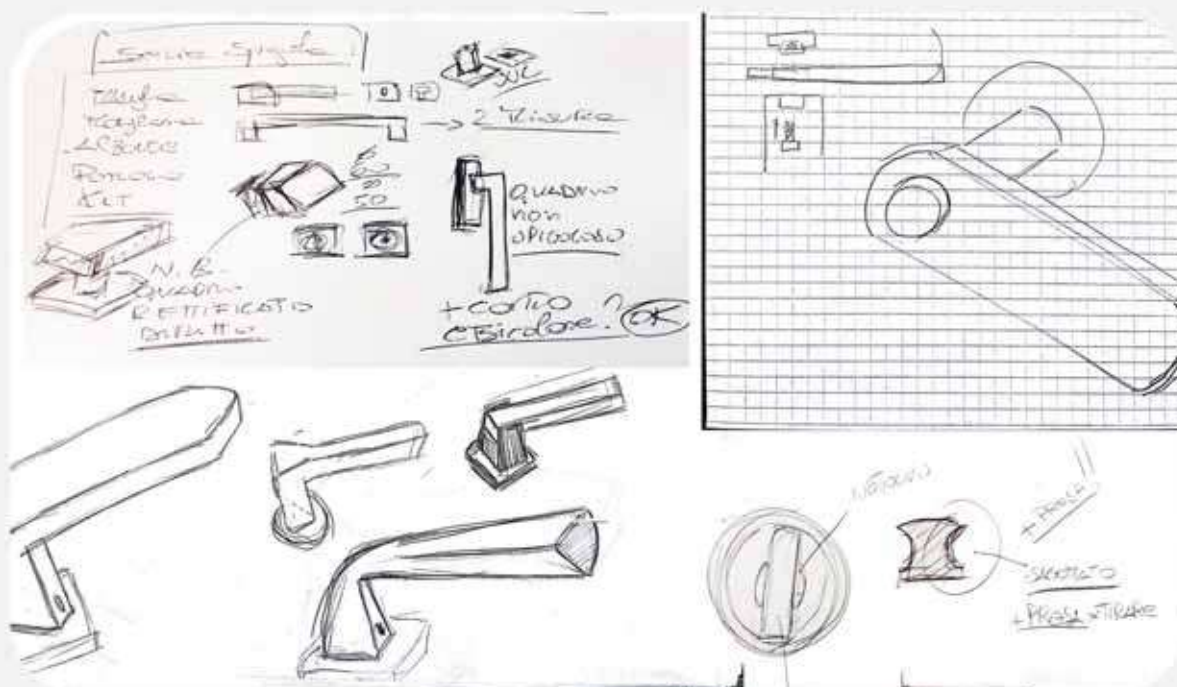

Il design è il punto d'incontro tra il passato ed il futuro, tra visione, tecnologia e creatività. Il design applicato ai nostri prodotti esprime lo stile italiano in accessori per porte, quali: maniglie, maniglioni, pomoli e coordinati. Proponiamo articoli che variano dal design contemporaneo più all'avanguardia ai richiami di stile classico ed intramontabile, dalle forme geometriche più essenziali ai disegni più ricercati. Il design però non è solo forme e linee, ma il giusto abbinamento tra l'idea del particolare e la sua realizzazione, con le giuste proporzioni e colori. Accompagnando questo concetto i nostri prodotti vengono dotati di finiture idonee al design dell'articolo seguito sempre da una linea di stile ed eleganza. Le finiture variano dai colori cromatici, satinati e bi-colore per le linee più moderne, fino ai colori antichi, che legano perfettamente con gli accessori più ricercati e classici.

The design is the point of encounter between the past and the future in a product, between vision, technology and creativity. The design applied to our products expresses the Italian style in accessories for doors, which: handles, pull handles, knob and accessories in brass. We propose articles that more vary from the contemporary design to the vanguard to the call backs of styles classics and eternal, from essential the geometric shapes to the designs more searches to you. The design is not only shapes and lines, but the just coupling between the idea of particular and its realization, with the just proportions and colours. Accompanying this concept our products come equip you of suitable finishes to the design of the article always followed from one line of style and elegance. The finishes vary from the colours chromium plated to us, satin and new the bicolour one for the more modern lines, until the old colours, that they tie perfectly with the accessories more searches and classics to you.

Qualità

Quality



La qualità è alla base di una grande azienda. Mariva controlla i propri prodotti con la massima accuratezza, partendo da materiali qualificati vengono controllate tutte le lavorazioni che si svolgono all'interno ed all'esterno della nostra azienda, in modo da poter offrire articoli con un'ottima qualità finale. Durante il ciclo produttivo i nostri articoli prevedono 5 controlli qualitativi intermedi che permettono una maggior selezione del materiale difettoso.

Quality is the foundation of a great company. Mariva controls its products with the highest accuracy, starting from suitable materials are checked all the processes that take place inside and outside of our company, so we can provide products with good quality finish. During the production cycle of our items 5 quality controls that provide intermediate allow a greater selection of the defective material.

Ambiente

Ecology



La salvaguardia dell'ambiente è essenziale per la qualità della vita delle generazioni presenti e future. Mariva cerca di combinare in modo ottimale nel lungo periodo la protezione dell'ambiente con le esigenze di un'economia in continua crescita. La politica ambientale Mariva si basa sulle più recenti normative europee, ogni fase di lavorazione interna ed esterna presta notevole attenzione alla tutela ed al rispetto dell'ambiente.

Protecting the environment is essential to the quality of life of present and future generations. Mariva tries to optimally combine the long-term protection of the environment with the needs of an economy growing. The environmental policy Mariva is based on the latest European standards, each stage of processing inner and outer devotes considerable attention to protecting and respecting the environment.



Maritech

Maritech



Maritech è una nuova lega di zinco, alluminio e magnesio. Attraverso il processo di pressofusione è possibile modellare questa lega in qualsiasi forma e genere di articolo, abbattendo sensibilmente i costi di produzione dovuti alle materie prime. Il pregio di questa lega, rispetto ad altre leghe più comuni, come zama e simili, è quello di avere un'elevata compattezza del materiale, ma nello stesso tempo anche un alto indice di malleabilità. Grazie a queste caratteristiche è possibile ottenere particolari semplici o complessi che possono, successivamente, essere lavorati e personalizzati. Dopo lavorazioni galvaniche di doratura e cromatura si possono ottenere le seguenti finiture: oro lucido, cromo satinato, cromo lucido, bi colore oro lucido/satinato e bicolore cromo lucido/satinato.

Maritech is a new alloy of zinc, aluminum and magnesium. Through the process of this alloy die casting can be modeled in any form or kind of item, significantly cutting the costs of production due to raw materials. The merit of this alloy, compared to other more common alloys, such as zinc and the like, is to have a high compactness of the material, but at the same time also a high index of malleability. With these you can get special characteristics simple or complex which can subsequently be processed and personalized. After galvanic gilding and plating can be obtained in the following finishes: polished gold, satin chrome, polished chrome, bi-colored gold polished / satin and polished chrome dual color / finish.

Ⓑ Ottone

brass



L'ottone è un materiale duttile e manleabile con un'ottima resistenza alla corrosione. I prodotti vengono realizzati tramite processo di fusione o stampaggio dell'ottone, permettendo di realizzare qualsiasi forma desiderata, dalla più moderna alla più classica. Grazie alle caratteristiche dell'ottone è possibile realizzare qualsiasi finitura richiesta sui prodotti.

Brass is a ductile material and manleabile with excellent resistance to corrosion. The products are manufactured through the process of melting or molding brass, allowing you to create any shape you want, from the most modern to the classic. Due to the characteristics of the brass finish is possible to realize any request about the products.



Pvd / Pvd inox

pvd / pvd inox



SISTEMA QUALITÀ
CERTIFICATO



CARATTERISTICA	RIFERIMENTO	PARAMETRI
Controllo visivo	Procedure interne	--
Parametri del colore su base lucida	DIN 6174	L = 80,0±15,0 a = -0,5 ±1,5 b = +26±3,0
Resistenza al CASS test	UNI ISO 9227	Minimo 72h per pezzi stampati a caldo Minimo 36h per pezzi pressofusi
Resistenza all'AASS test	UNI ISO 9227	Minimo 112h per pezzi stampati a caldo Minimo 72h per pezzi pressofusi
Resistenza al NSS test	UNI ISO 9227	Minimo 3000h per pezzi stampati a caldo Minimo 1500h per pezzi pressofusi
Aderenza	UNI ISO 4524-5	Shock termico da 250°C a temperatura ambiente
Spessori	ISO 3497	PVD > 0.15µm
Durezza superficiale	ASTM B578-93	> 2000 HV
Resistenza all'abrasione:	JIS H 8682	WRf > 4000 µm
Stabilità del colore:	ASTM 870-92	Immersione in acqua ultradema a 80°C per 24h; con variazioni di a <0,3 e b <3,5.
Resistenza ad acidi e alcali	--	Il rivestimento resiste ai seguenti agenti chimici: acido cloridrico, solforico, nitrico, ossalico, acetico e citrico; soda e potassa caustica, cianuri e sgrassature alcaline a caldo.

Frutto di una tecnologia assolutamente ecologica, il PVD è nato da una recente tecnica aerospaziale poi adottata per uso industriale, la quale è particolarmente indicata su articoli che necessitano di rivestimenti perchè sottoposti ad usura per sfregamento o perchè utilizzati in ambienti corrosivi. Il rivestimento consiste nel deposito di alcuni micron di materiale metallico evaporato in una apposita camera sottovuoto (physical vapour deposition). L'atmosfera controllata e la concentrazione di gas presenti nella camera sottovuoto permettono di depositare un finissimo strato di nitrato di zirconio-titanio sulla superficie dei pezzi, garantendo così una maggior durezza del prodotto, rispetto alle lavorazioni tradizionali. Questo specifico trattamento permette di avere prodotti la cui brillantezza non verrà alterata dagli agenti atmosferici o dall'usura dovuta all'utilizzo. Questa lavorazione viene proposta in due diverse colorazioni: PVD (dal classico color oro intenso) e PVD-INOX (superficie opacizzata, molto simile all'acciaio inox). Gli articoli con queste finiture sono garantiti nel tempo.

An absolutely ecological technology, the PVD is born from a recent aerospace technique then adopted for industrial use, which particularly is indicated for particular that they need of coverings because subordinates to usury for rubbing or because use you in atmospheres corroded to you. The covering consists in the warehouse of some micron of metallic material evaporated in one appropriate room sottovuoto (physical vapour deposition). The controlled atmosphere and the present gas concentration in the room sottovuoto allow to deposit a most fine zirconium-titanium nitride layer on a surface of pieces, being guaranteed therefore one greater hardness of the product, regarding the traditional workings. This specific treatment allows to have produced whose brilliance will not come altered from the atmospheric agents or from the usury due to I use it. This working comes proposed in two various colorations: PVD (from the classic color intense gold) and the PVD-INOX (opacified surface, much similar one to the stainless steel). The articles with these finishes come guaranteed in the time just for their characteristics of great resistance.



Dk di sicurezza

security dry keep



Questa nuova soluzione permette di azionare il movimento della maniglia solo premendo l'apposito pulsante, questo dispositivo permette di aver una maggior sicurezza contro i ladri e una maggior garanzia nell'evitare l'apertura accidentale da parte dei bambini. Questo sistema è abbinabile a tutte le maniglie Mariva (su anticipata richiesta) ed è disponibile con cover ovale o rettangolare.

This new solution allows you to operate the movement of the handle just by pressing the button, this device allows you to have greater security against thieves and a greater guarantee to avoid the rough opening by children. This system can be combined with all the handles Mariva (on advance request) and is available with oval or cover rectangular.



Confezione plus

box plus



L'imballo del prodotto è molto importante per mantenere integro l'articolo fino al momento dell'utilizzo, pertanto gli articoli più delicati ed importanti vengono confezionati con appositi imballi sagomati in polistirolo espanso che permettono di mantenere i prodotti Mariva ben conservati fino al momento dell'installazione.

The packaging of the product is very important to keep the article intact until time of use, so the most delicate and important items are packaged with special packaging molded polystyrene foam that allow you to keep products Mariva well preserved until the time of the installation.

Convenzioni

convention

mezza maniglia
destra
half right handle



mezza maniglia
sinistra
half left handle



Una maniglia convenzionale è composta da una
maniglia destra e da una mezza maniglia sinistra

*Conventional handle is composed of a right handle half and a
left handle half.*

Finiture



PVD
Ottone PVD



PVD INOX
Ottone
PVD INOX



PVD/SAT
Ottone bicolore
PVD / SAT



CS
Ottone cromato
satinato



BG
Ottone bronzato
graffiato



OLV
Ottone lucido
verniciato



CR
Ottone cromato
lucido



BU
Ottone bronzato
uniforme



SV
Ottone satinato
verniciato



CR/CS
Ottone bicolore
CR/CS



BS
Ottone bronzato
sfumato



OLV/OLS
Ottone bicolore
OLV/OLS



NKS
Ottone nichelato
satinato



BR
Ottone bronzato
verniciato



MORO
Maritech ORO



MCS
Maritech
cromato satinato



MBG
Maritech
bronzato graffiato



MCR
Maritech
cromato lucido



MCR/CS
Maritech
bicolore CR/CS



Finiture



ANT
Ottone bronzo
antico



BIA
Verniciato
bianco



ORO
Ottone oro
antico



ARG
Ottone argento
antico



NO
Verniciato nero
opaco



RAM
Ottone ramato
antico



NL
Verniciato nero
lucido



AVO
Verniciato
avorio



SAB
Verniciato
sabbia

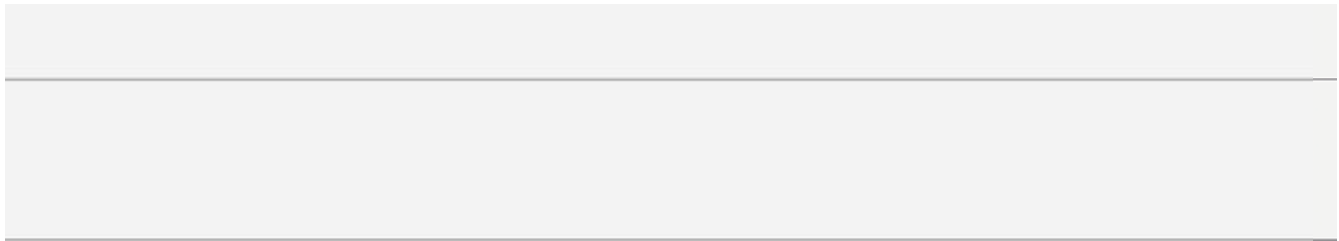

Maniglie su rosetta quadra



768
Toga
pag. 27



769
Cuba
pag. 28



769B
Cuba B
pag. 29



770
Milano
pag. 30



771
Monza
pag. 31



812
Crystal
pag. 32



813
Shine
pag. 33



766
Spigola
pag. 24



766B
Spigola B
pag. 25



767
Composita
pag. 26



1127
Nuvola
pag. 34



1127B
Nuvola B
pag. 35



1129
Arianna
pag. 36



1130
Kioto
pag. 37



2105
Lotus
pag. 38



2106
Trix
pag. 39



2107
Square
pag. 40



2108
Zonta
pag. 41



2109
Honey
pag. 42



2110B
Luxury B
pag. 43



2111B
Prestige B
pag. 44



2112
Space
pag. 45



2147
Linzi
pag. 46

766 Spigola

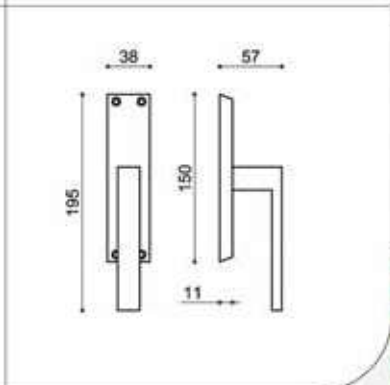
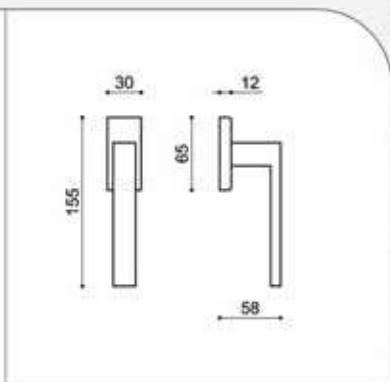
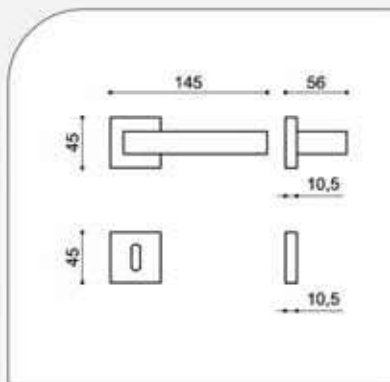

Rosetta standard:
RQ45 rosetta quadra mm 45x45

Varianti:
RQ50 rosetta quadra mm 50x50
RR rosetta rettangolare mm 30x65
nottolino Wc abbinato da pag. 320

Dry keep standard:
DQ dry keep quadro con mov. in metallo
7x42 mm con boccole art. 1672 pag. 364

Martellina standard:
placca art. P109 pag. 359 con quadro 7 mm

Cremonese standard:
placca art. P109 pag. 359
movimento intercambiabile art. 1551 pag.365

finiture:
MCS maritech cromato satinato
MCR maritech cromato lucido
MNO maritech verniciato nero opaco
MBIA maritech verniciato bianco
MAVO maritech verniciato avorio
MSAB maritech verniciato sabbia

766B Spigola B

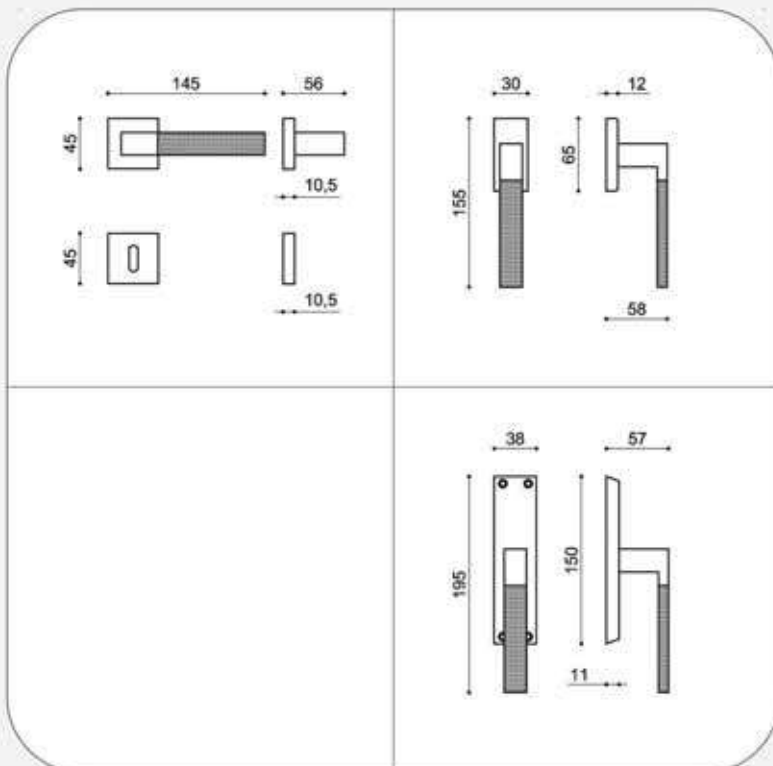

Rosetta standard:
RQ45 rosetta quadra mm 45x45

Varianti:
RQ50 rosetta quadra mm 50x50
RR rosetta rettangolare mm 30x65
nottolino Wc abbinato da pag. 320

Dry keep standard:
DQ dry keep quadro con mov. in metallo
7x42 mm con boccole art. 1672 pag. 364

Martellina standard:
placca art. P109 pag. 359 con quadro 7 mm

Cremonese standard:
placca art. P109 pag. 359
movimento intercambiabile art. 1551 pag.365

finiture:
MCR/CS maritech bi colore cromo/satinato

767 Composita

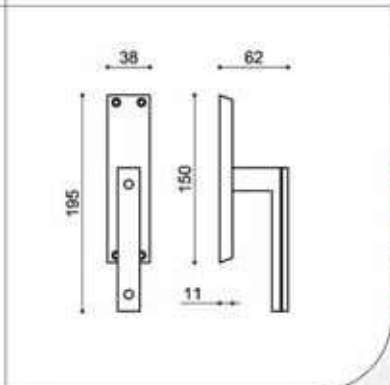
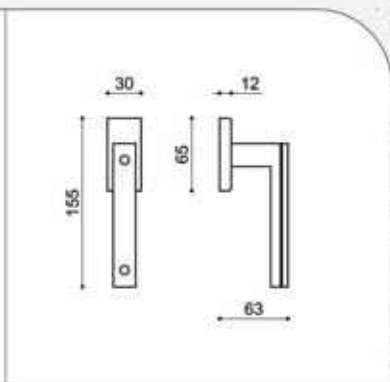
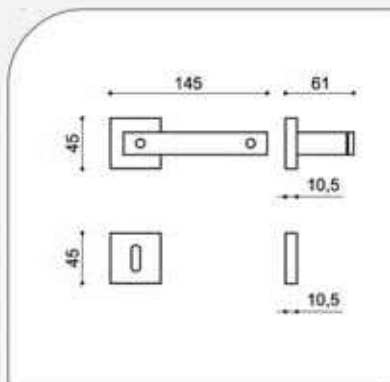

Rosetta standard:
RQ45 rosetta quadra mm 45x45

Varianti:
RQ50 rosetta quadra mm 50x50
RR rosetta rettangolare mm 30x65
nottolino Wc abbinato da pag. 320

Dry keep standard:
DQ dry keep quadro con mov. in metallo
7x42 mm con boccole art. 1672 pag. 364

Martellina standard:
placca art. P109 pag. 359 con quadro 7 mm

Cremonese standard:
placca art. P109 pag. 359
movimento intercambiabile art. 1551 pag.365

finiture:
MCS maritech cromato satinato
MCR maritech cromato lucido

plex:
RO plex rosso lucido
BI plex bianco lucido
NE plex nero lucido

esempio codice finitura:
MCRNEmaniglia cromo lucido plex nero lucido

768 Toga

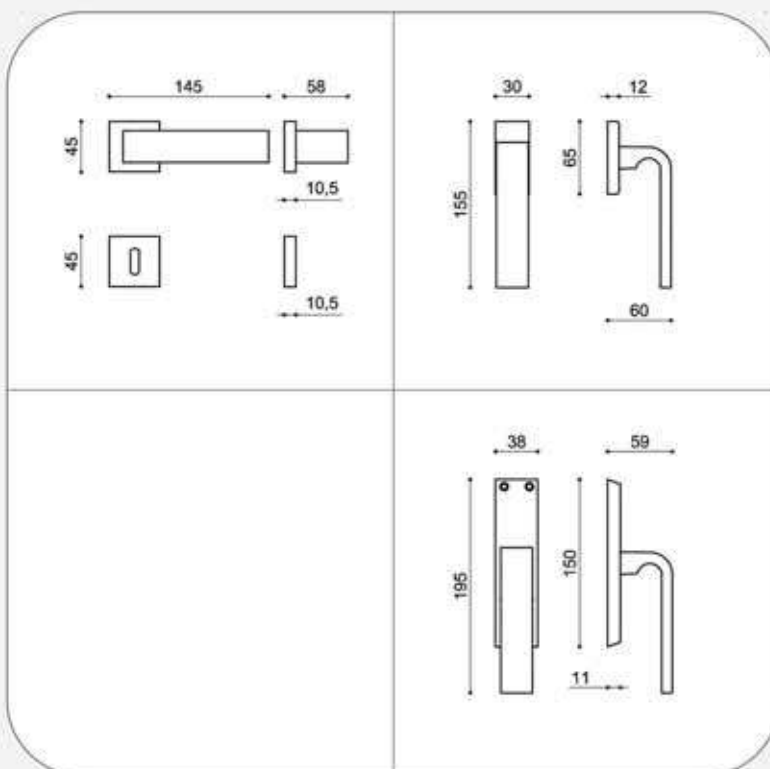

Rosetta standard:
RQ45 rosetta quadra mm 45x45

Varianti:
RQ50 rosetta quadra mm 50x50
RR rosetta rettangolare mm 30x65
nottolino Wc abbinato da pag. 320

Dry keep standard:
DQ dry keep quadro con mov. in metallo
7x42 mm con boccole art. 1672 pag. 364

Martellina standard:
placca art. P109 pag. 359 con quadro 7 mm

Cremonese standard:
placca art. P109 pag. 359
movimento intercambiabile art. 1551 pag.365

finiture:
MCS maritech cromato satinato
MCR maritech cromato lucido

769 Cuba

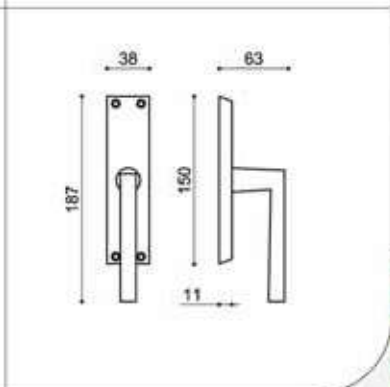
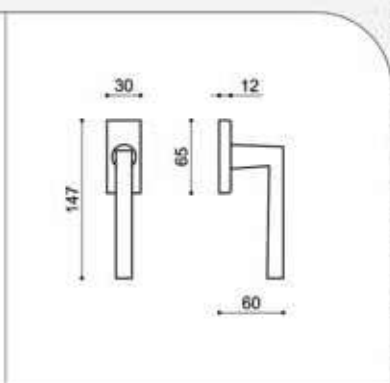
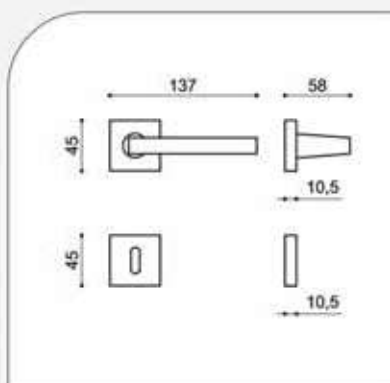

Rosetta standard:
RQ45 rosetta quadra mm 45x45

Varianti:
RQ50 rosetta quadra mm 50x50
RR rosetta rettangolare mm 30x65
nottolino Wc abbinato da pag. 320

Dry keep standard:
DQ dry keep quadro con mov. in metallo
7x42 mm con boccole art. 1672 pag. 364

Martellina standard:
placca art. P109 pag. 359 con quadro 7 mm

Cremonese standard:
placca art. P109 pag. 359
movimento intercambiabile art. 1551 pag.365

finiture:
MCS maritech cromato satinato
MCR maritech cromato lucido
MNO maritech verniciato nero opaco
MBIA maritech verniciato bianco
MAVO maritech verniciato avorio
MSAB maritech verniciato sabbia

769B Cuba B

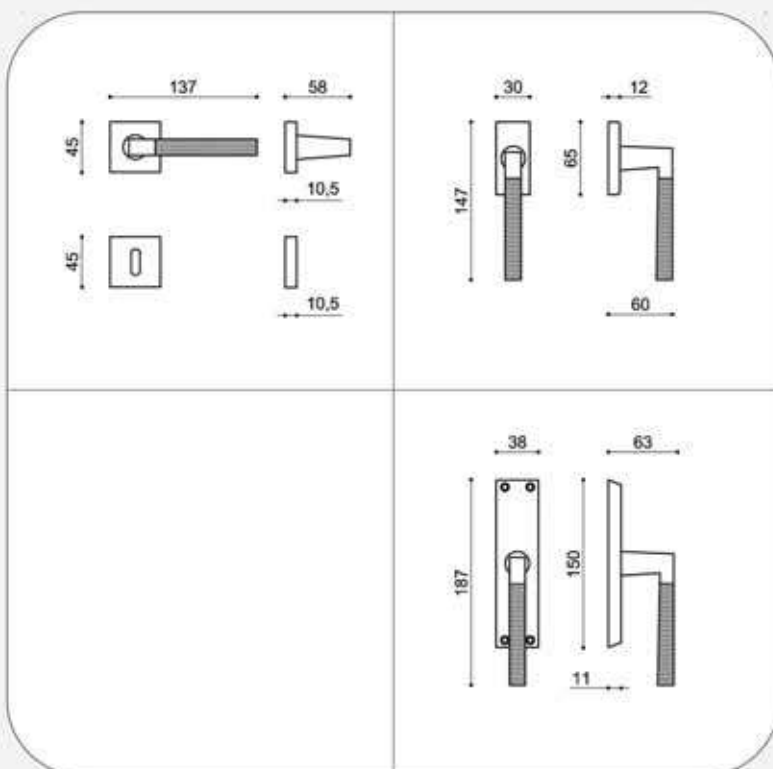

Rosetta standard:
RQ45 rosetta quadra mm 45x45

Varianti:
RQ50 rosetta quadra mm 50x50
RR rosetta rettangolare mm 30x65
nottolino Wc abbinato da pag. 320

Dry keep standard:
DQ dry keep quadro con mov. in metallo
7x42 mm con boccole art. 1672 pag. 364

Martellina standard:
placca art. P109 pag. 359 con quadro 7 mm

Cremonese standard:
placca art. P109 pag. 359
movimento intercambiabile art. 1551 pag.365

finiture:
MCR/CS maritech bi colore cromo/satinato

770 Milano

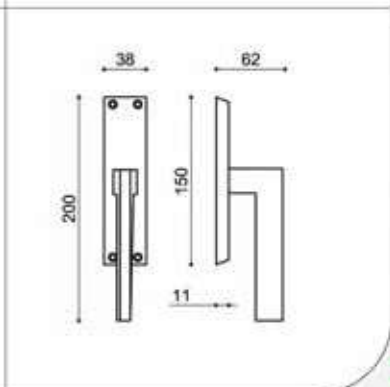
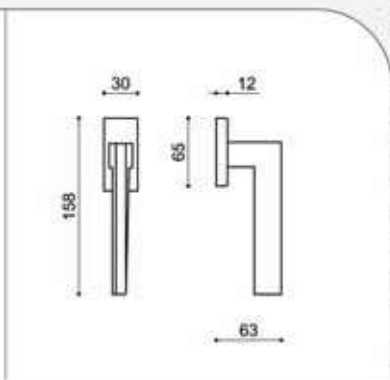
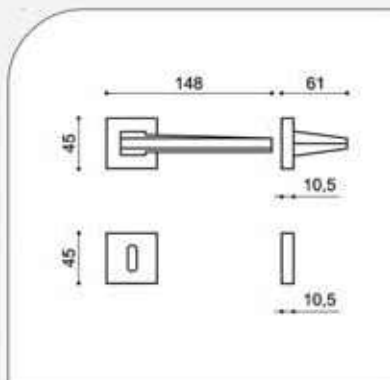

Rosetta standard:
RQ45 rosetta quadra mm 45x45

Varianti:
RQ50 rosetta quadra mm 50x50
RR rosetta rettangolare mm 30x65
nottolino Wc abbinato da pag. 320

Dry keep standard:
DQ dry keep quadro con mov. in metallo
7x42 mm con boccole art. 1672 pag. 364

Martellina standard:
placca art. P109 pag. 359 con quadro 7 mm

Cremonese standard:
placca art. P109 pag. 359
movimento intercambiabile art. 1551 pag.365

finiture:
MCS maritech cromato satinato
MCR maritech cromato lucido

771 Monza

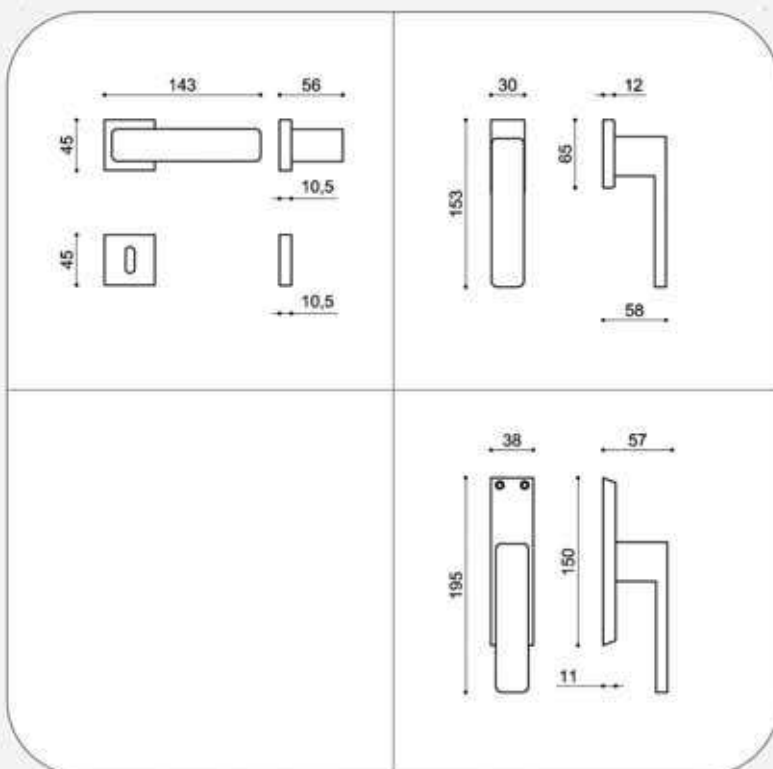

Rosetta standard:
RQ45 rosetta quadra mm 45x45

Varianti:
RQ50 rosetta quadra mm 50x50
RR rosetta rettangolare mm 30x65
 nottolino Wc abbinato da pag. 320

Dry keep standard:
DQ dry keep quadro con mov. in metallo
 7x42 mm con boccole art. 1672 pag. 364

Martellina standard:
 placca art. P109 pag. 359 con quadro 7 mm

Cremonese standard:
 placca art. P109 pag. 359
 movimento intercambiabile art. 1551 pag.365

finiture:
MCS maritech cromato satinato

812 Crystal

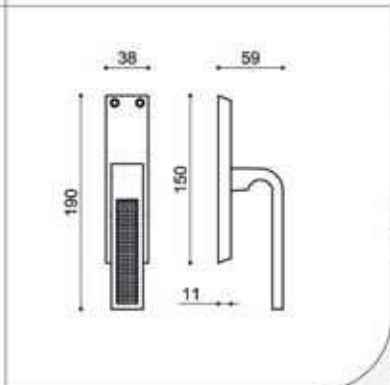
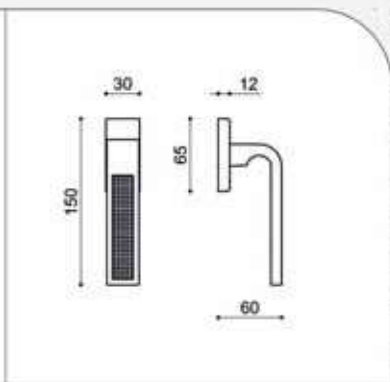
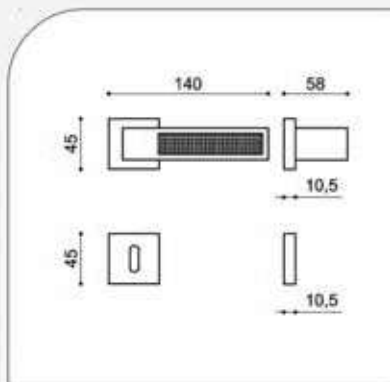

Rosetta standard:
RQ45 rosetta quadra mm 45x45

Varianti:
RQ50 rosetta quadra mm 50x50
RR rosetta rettangolare mm 30x65
nottolino Wc abbinato da pag. 320

Dry keep standard:
DQ dry keep quadro con mov. in metallo
7x42 mm con boccole art. 1672 pag. 364

Martellina standard:
placca art. P109 pag. 359 con quadro 7 mm

Cremonese standard:
placca art. P109 pag. 359
movimento intercambiabile art. 1551 pag.365

MADE WITH
CRYSTAL
LIFE
SWAROVSKI ELEMENTS

finiture:
CS ottone cromato satinato
CR ottone cromato lucido

813 Shine

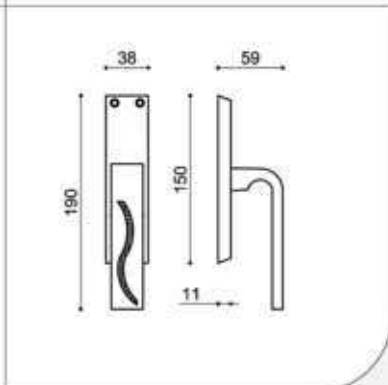
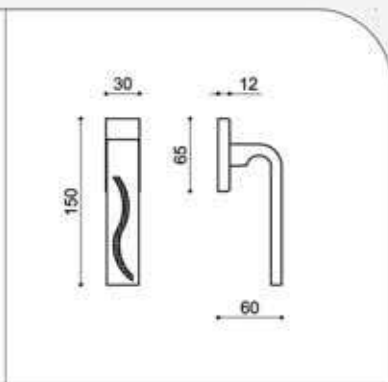
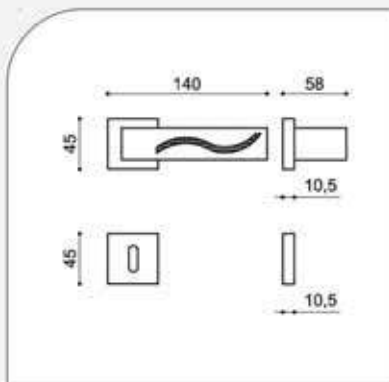

Rosetta standard:
RQ45 rosetta quadra mm 45x45

Varianti:
RQ50 rosetta quadra mm 50x50
RR rosetta rettangolare mm 30x65
nottolino Wc abbinato da pag. 320

Dry keep standard:
DQ dry keep quadro con mov. in metallo
7x42 mm con boccole art. 1672 pag. 364

Martellina standard:
placca art. P109 pag. 359 con quadro 7 mm

Cremonese standard:
placca art. P109 pag. 359
movimento intercambiabile art. 1551 pag.365

MADE WITH
**CRYSTAL
LIFE**
SWAROVSKI ELEMENTS

finiture:
CS ottone cromato satinato
CR ottone cromato lucido

1127 Nuvola



versione con rosetta quadra

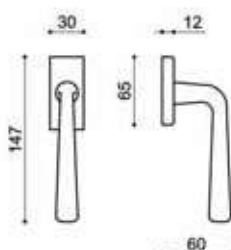
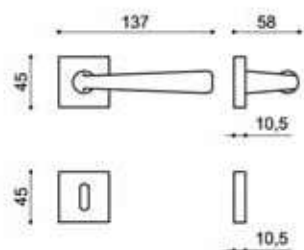
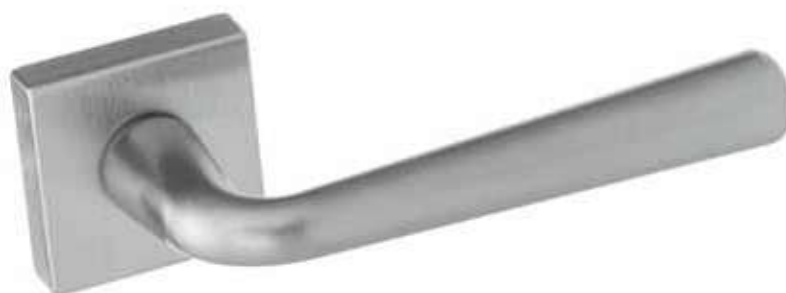

Rosetta standard:
RQ45 rosetta quadra mm 45x45

Varianti:
RQ50 rosetta quadra mm 50x50
RR rosetta rettangolare mm 30x65
nottolino Wc abbinato da pag. 320

Dry keep standard:
DQ dry keep quadro con mov. in metallo
7x42 mm con boccole art. 1672 pag. 364

Martellina standard:
placca art. P109 pag. 359 con quadro 7 mm

Cremonese standard:
placca art. P109 pag. 359
movimento intercambiabile art. 1551 pag.365

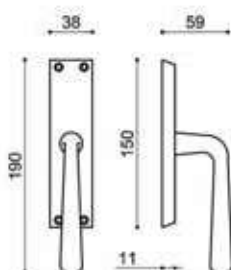

finiture:
MCS maritech cromato satinato
MCR maritech cromato lucido

1127B Nuvola B



versione con rosetta quadra

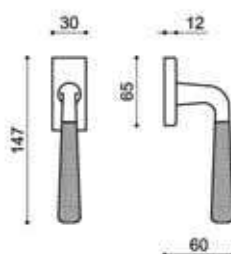
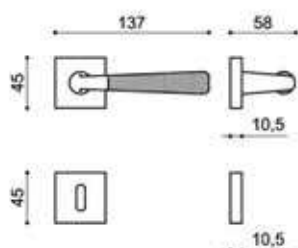

Rosetta standard:
RQ45 rosetta quadra mm 45x45

Varianti:
RQ50 rosetta quadra mm 50x50
RR rosetta rettangolare mm 30x65
nottolino Wc abbinato da pag. 320

Dry keep standard:
DQ dry keep quadro con mov. in metallo
7x42 mm con boccole art. 1672 pag. 364

Martellina standard:
placca art. P109 pag. 359 con quadro 7 mm

Cremonese standard:
placca art. P109 pag. 359
movimento intercambiabile art. 1551 pag.365

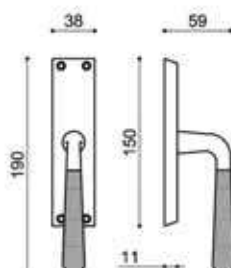

finiture:
MCR/CS maritech bi colore cromo/satinato

1129 Arianna



versione con rosetta quadra

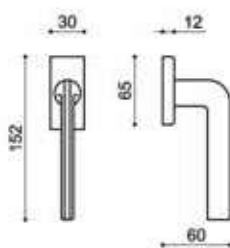
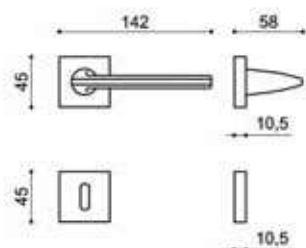

Rosetta standard:
RQ45 rosetta quadra mm 45x45

Varianti:
RQ50 rosetta quadra mm 50x50
RR rosetta rettangolare mm 30x65
nottolino Wc abbinato da pag. 320

Dry keep standard:
DQ dry keep quadro con mov. in metallo
7x42 mm con boccole art. 1672 pag. 364

Martellina standard:
placca art. P109 pag. 359 con quadro 7 mm

Cremonese standard:
placca art. P109 pag. 359
movimento intercambiabile art. 1551 pag.365

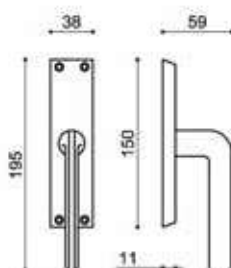

finiture:
MCS maritech cromato satinato
MCR maritech cromato lucido

1130 Kioto



versione con rosetta quadra

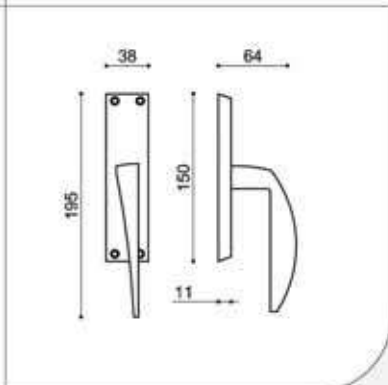
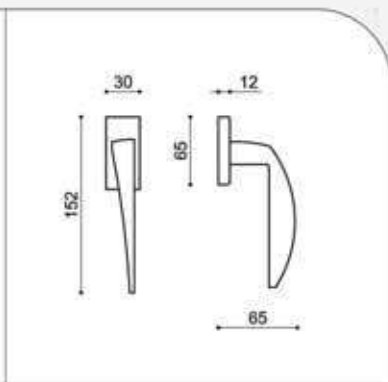
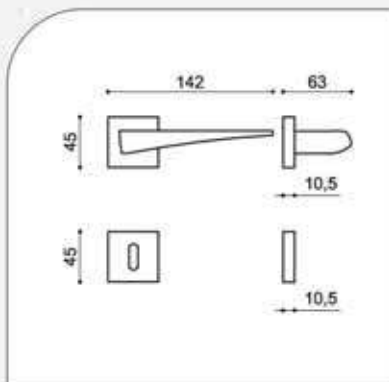

Rosetta standard:
RQ45 rosetta quadra mm 45x45

Varianti:
RQ50 rosetta quadra mm 50x50
RR rosetta rettangolare mm 30x65
nottolino Wc abbinato da pag. 320

Dry keep standard:
DQ dry keep quadro con mov. in metallo
7x42 mm con boccole art. 1672 pag. 364

Martellina standard:
placca art. P109 pag. 359 con quadro 7 mm

Cremonese standard:
placca art. P109 pag. 359
movimento intercambiabile art. 1551 pag.365

finiture:
MCS maritech cromato satinato

2105 Lotus

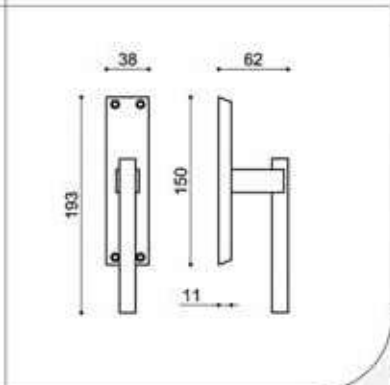
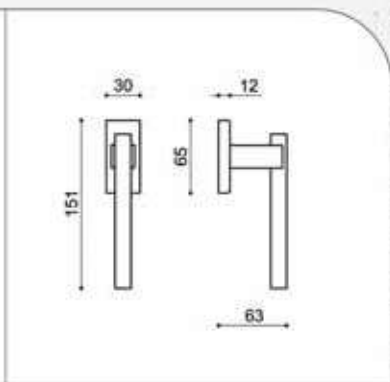
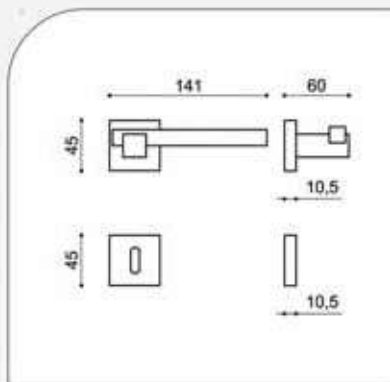

Rosetta standard:
RQ45 rosetta quadra mm 45x45

Varianti:
RQ50 rosetta quadra mm 50x50
RR rosetta rettangolare mm 30x65
nottolino Wc abbinato da pag. 320

Dry keep standard:
DQ dry keep quadro con mov. in metallo
7x42 mm con boccole art. 1672 pag. 364

Martellina standard:
placca art. P109 pag. 359 con quadro 7 mm

Cremonese standard:
placca art. P109 pag. 359
movimento intercambiabile art. 1551 pag.365

finiture:
CS ottone cromato satinato
CR ottone cromato lucido
CR/CS ottone bi colore cromo/satinato

2106 Trix

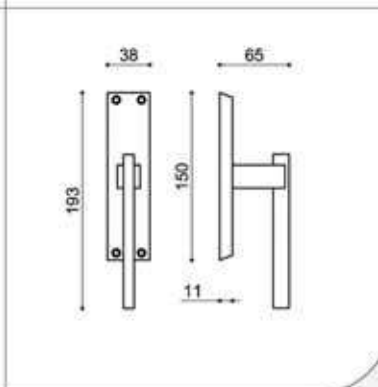
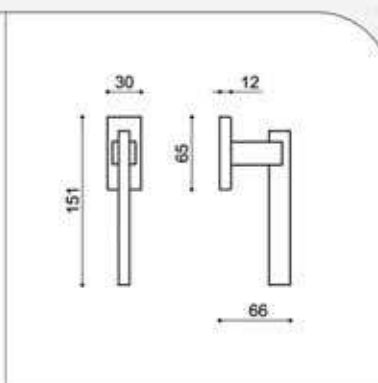
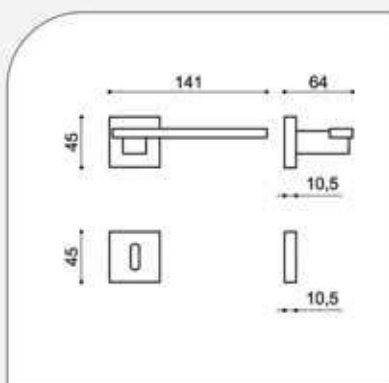
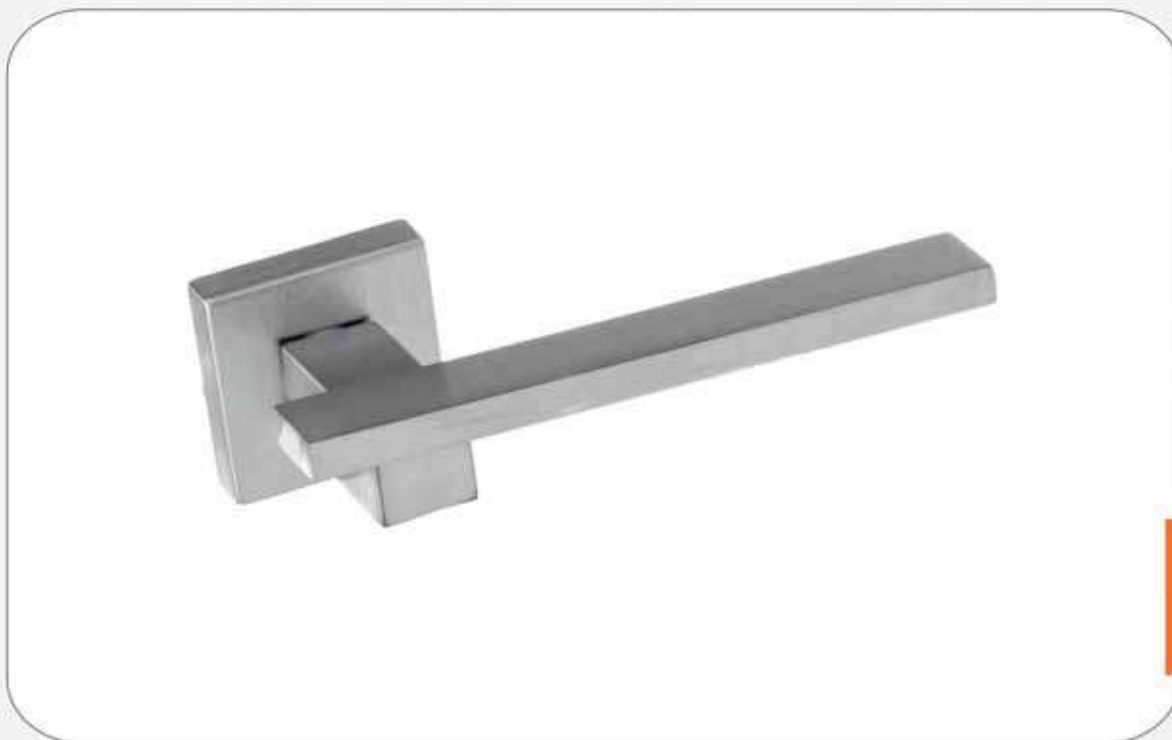

Rosetta standard:
RQ45 rosetta quadra mm 45x45

Varianti:
RQ50 rosetta quadra mm 50x50
RR rosetta rettangolare mm 30x65
nottolino Wc abbinato da pag. 320

Dry keep standard:
DQ dry keep quadro con mov. in metallo
7x42 mm con boccole art. 1672 pag. 364

Martellina standard:
placca art. P109 pag. 359 con quadro 7 mm

Cremonese standard:
placca art. P109 pag. 359
movimento intercambiabile art. 1551 pag.365

finiture:
CS ottone cromato satinato
CR ottone cromato lucido
CR/CS ottone bi colore cromo/satinato

2107 Square

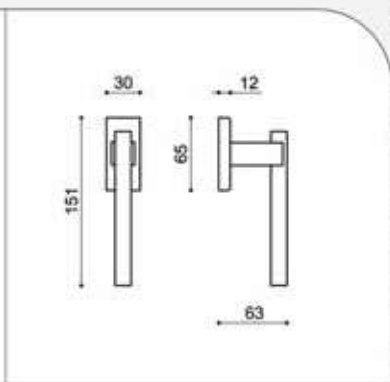
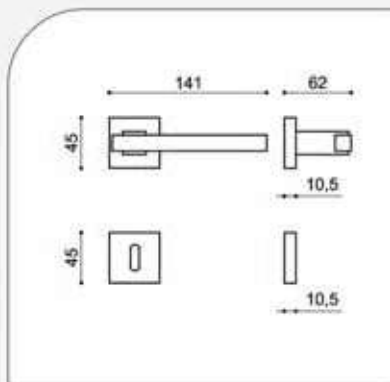

Rosetta standard:
RQ45 rosetta quadra mm 45x45

Varianti:
RQ50 rosetta quadra mm 50x50
RR rosetta rettangolare mm 30x65
nottolino Wc abbinato da pag. 320

Dry keep standard:
DQ dry keep quadro con mov. in metallo
7x42 mm con boccole art. 1672 pag. 364

Martellina standard:
placca art. P109 pag. 359 con quadro 7 mm

Cremonese standard:
placca art. P109 pag. 359
movimento intercambiabile art. 1551 pag.365

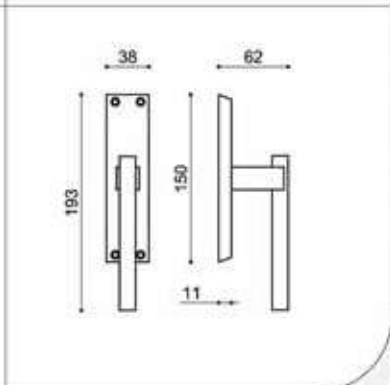

finiture:
CS ottone cromato satinato
CR ottone cromato lucido
CR/CS ottone bi colore cromo/satinato

2108 Zonta

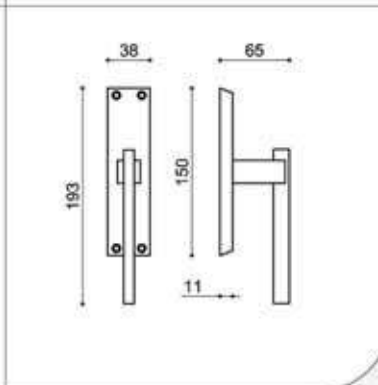
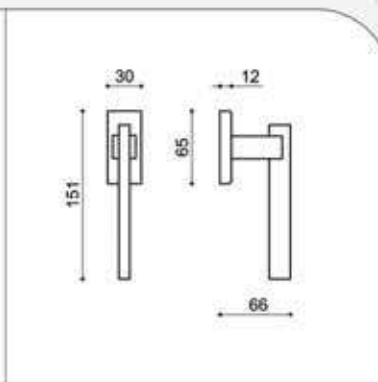
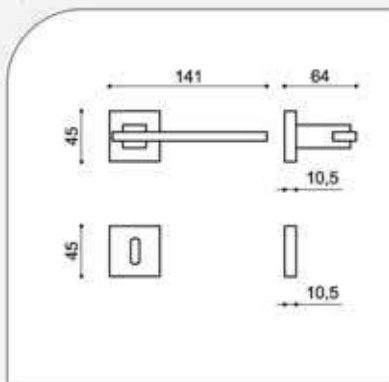

Rosetta standard:
RQ45 rosetta quadra mm 45x45

Varianti:
RQ50 rosetta quadra mm 50x50
RR rosetta rettangolare mm 30x65
nottolino Wc abbinato da pag. 320

Dry keep standard:
DQ dry keep quadro con mov. in metallo
7x42 mm con boccole art. 1672 pag. 364

Martellina standard:
placca art. P109 pag. 359 con quadro 7 mm

Cremonese standard:
placca art. P109 pag. 359
movimento intercambiabile art. 1551 pag.365

finiture:
CS ottone cromato satinato
CR ottone cromato lucido
CR/CS ottone bi colore cromo/satinato

2109 Honey

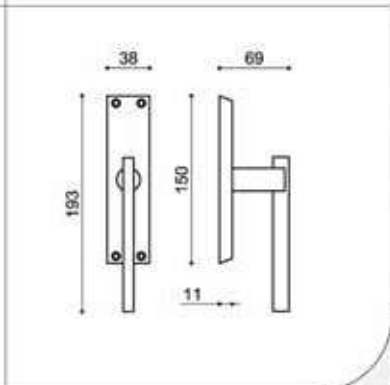
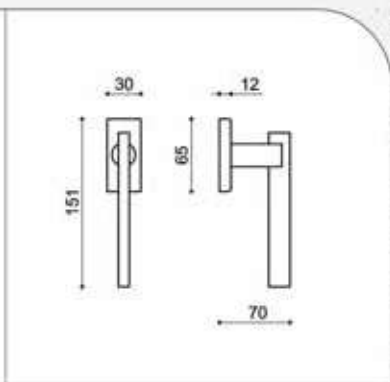
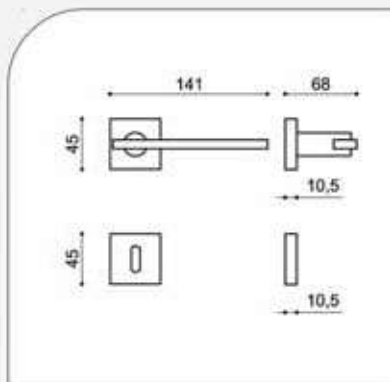
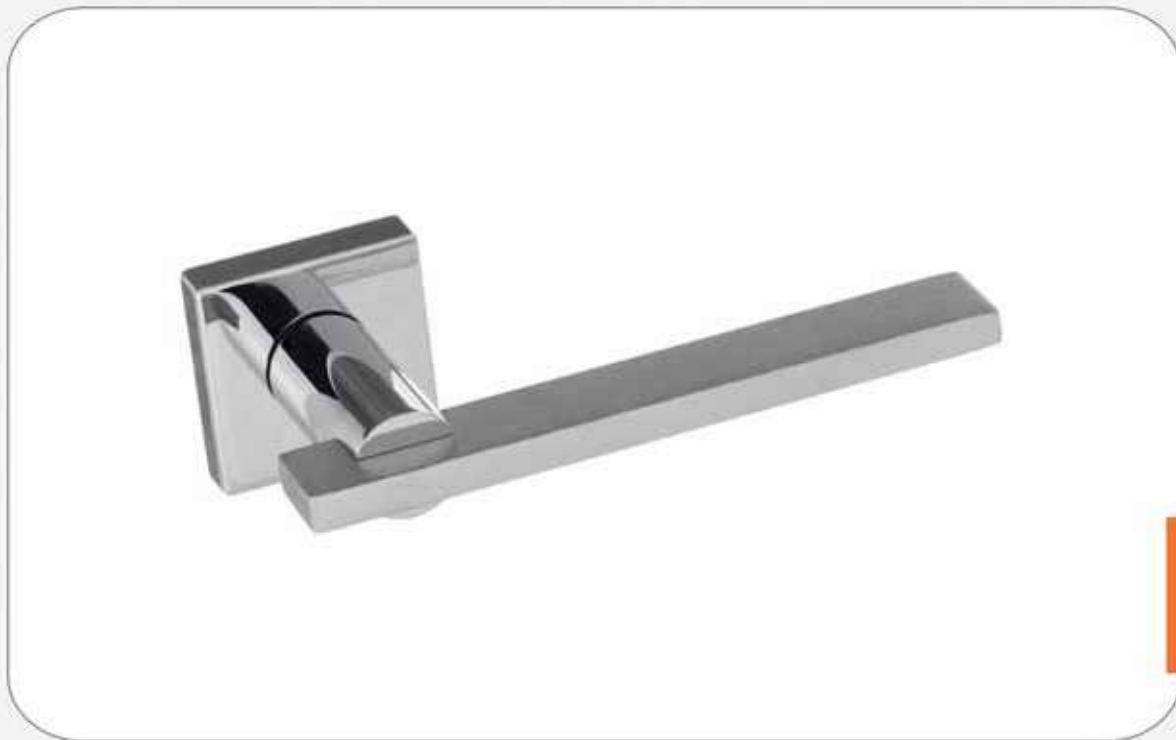

Rosetta standard:
RQ45 rosetta quadra mm 45x45

Varianti:
RQ50 rosetta quadra mm 50x50
RR rosetta rettangolare mm 30x65
nottolino Wc abbinato da pag. 320

Dry keep standard:
DQ dry keep quadro con mov. in metallo
7x42 mm con boccole art. 1672 pag. 364

Martellina standard:
placca art. P109 pag. 359 con quadro 7 mm

Cremonese standard:
placca art. P109 pag. 359
movimento intercambiabile art. 1551 pag.365

finiture:
CS ottone cromato satinato
CR ottone cromato lucido
CR/CS ottone bi colore cromo/satinato

2110B Luxury B

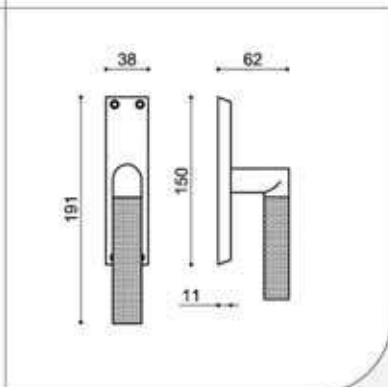
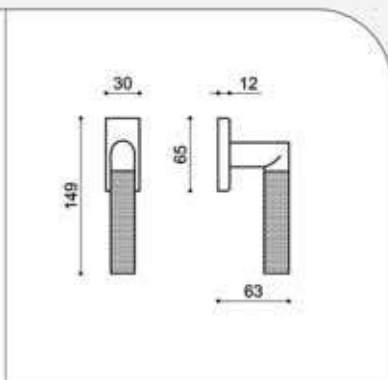
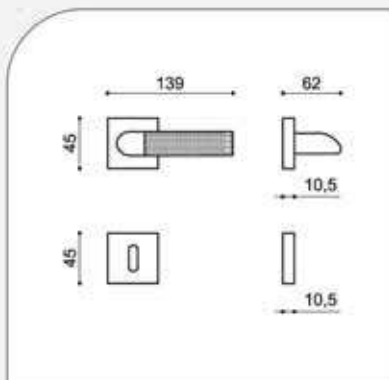

Rosetta standard:
RQ45 rosetta quadra mm 45x45

Varianti:
RQ50 rosetta quadra mm 50x50
RR rosetta rettangolare mm 30x65
nottolino Wc abbinato da pag. 320

Dry keep standard:
DQ dry keep quadro con mov. in metallo
7x42 mm con boccole art. 1672 pag. 364

Martellina standard:
placca art. P109 pag. 359 con quadro 7 mm

Cremonese standard:
placca art. P109 pag. 359
movimento intercambiabile art. 1551 pag.365

finiture:
OLV/OLS ottone bi colore lucido/satinato
CR/CS ottone bi colore cromo/satinato

2111B Prestige B

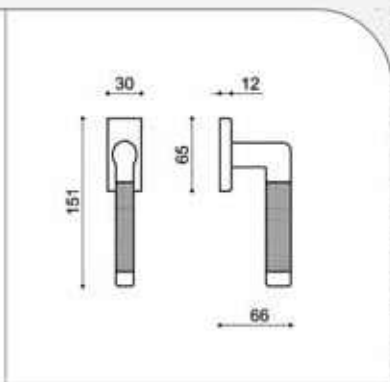
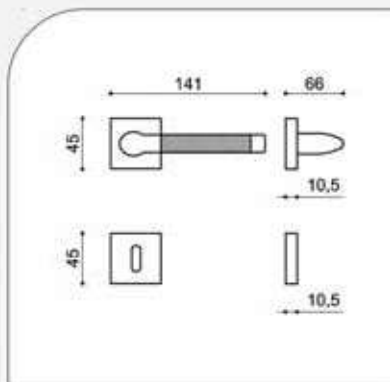

Rosetta standard:
RQ45 rosetta quadra mm 45x45

Varianti:
RQ50 rosetta quadra mm 50x50
RR rosetta rettangolare mm 30x65
nottolino Wc abbinato da pag. 320

Dry keep standard:
DQ dry keep quadro con mov. in metallo
7x42 mm con boccole art. 1672 pag. 364

Martellina standard:
placca art. P109 pag. 359 con quadro 7 mm

Cremonese standard:
placca art. P109 pag. 359
movimento intercambiabile art. 1551 pag.365

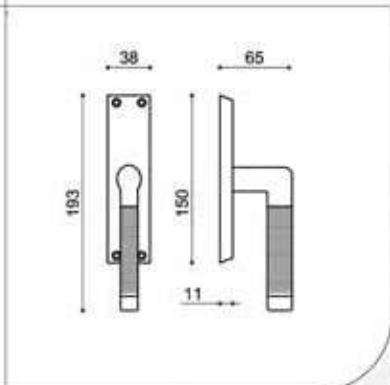

finiture:
OLV/OLS ottone bi colore lucido/satinato
CR/CS ottone bi colore cromo/satinato

2112 Space

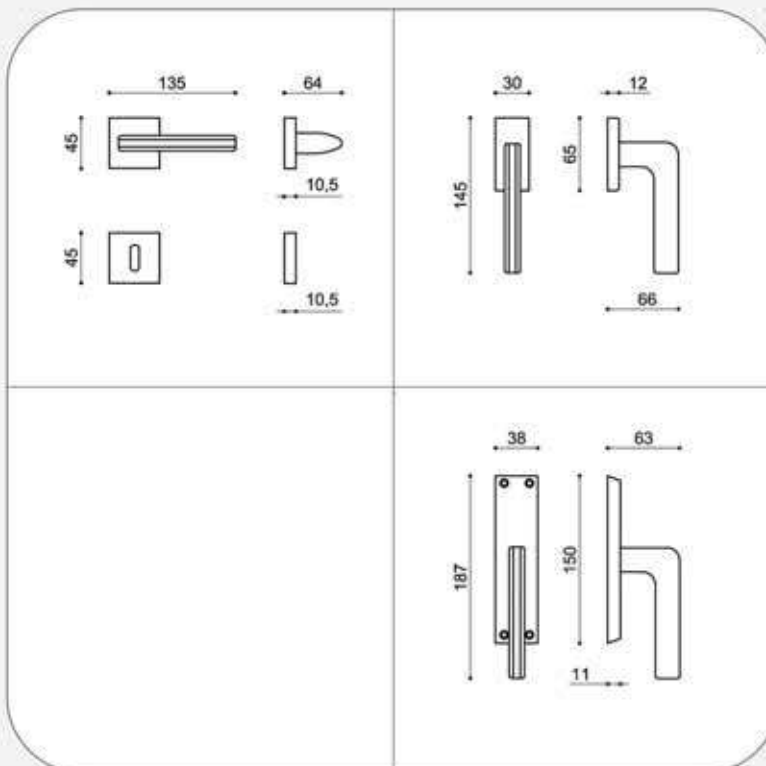

Rosetta standard:
RQ45 rosetta quadra mm 45x45

Varianti:
RQ50 rosetta quadra mm 50x50
RR rosetta rettangolare mm 30x65
nottolino Wc abbinato da pag. 320

Dry keep standard:
DQ dry keep quadro con mov. in metallo
7x42 mm con boccole art. 1672 pag. 364

Martellina standard:
placca art. P109 pag. 359 con quadro 7 mm

Cremonese standard:
placca art. P109 pag. 359
movimento intercambiabile art. 1551 pag.365

finiture:
OLV ottone lucido verniciato
CS ottone cromato satinato
CR ottone cromato lucido

2147 Linzi

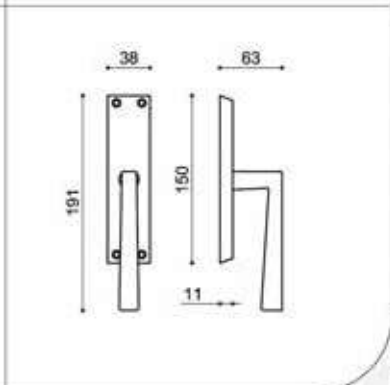
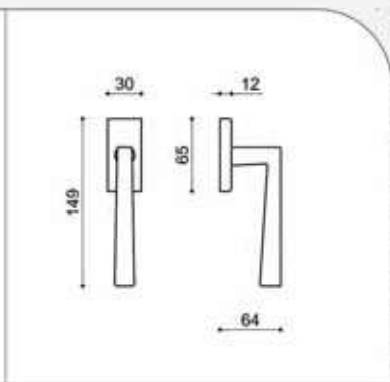
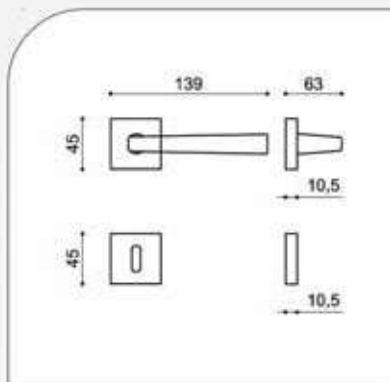

Rosetta standard:
RQ45 rosetta quadra mm 45x45

Varianti:
RQ50 rosetta quadra mm 50x50
RR rosetta rettangolare mm 30x65
nottolino Wc abbinato da pag. 320

Dry keep standard:
DQ dry keep quadro con mov. in metallo
7x42 mm con boccole art. 1672 pag. 364

Martellina standard:
placca art. P109 pag. 359 con quadro 7 mm

Cremonese standard:
placca art. P109 pag. 359
movimento intercambiabile art. 1551 pag.365

finiture:
OLV ottone lucido verniciato
CS ottone cromato satinato
CR ottone cromato lucido

Riferimenti rosette quadre

Placca rettangolare per maniglia *(su richiesta)*
pagina 358

Placca rettangolare per martellina/cremonese
pagina 359

Rosette e bocchette quadre mm 45x45
pagina 362

Rosette e bocchette quadre mm 50x50
pagina 362

Rosette e bocchette rettangolari
pagina 362

Nottolini Wc quadri e rettangolari
da pagina 320



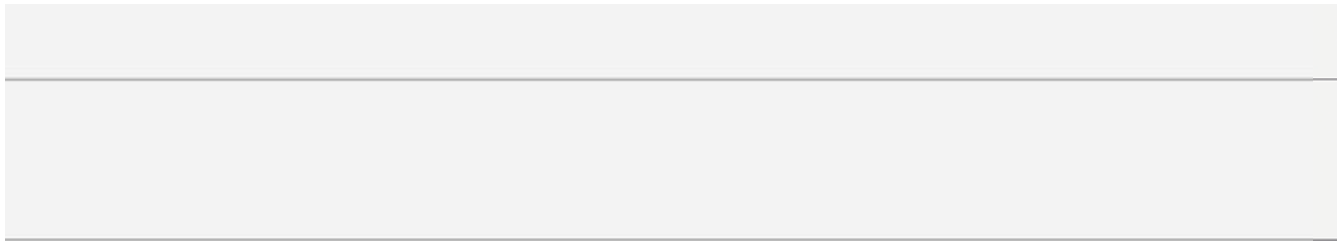

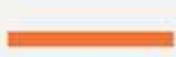

Maniglie su rosetta *slim*



769
Cuba
pag. 50



769B
Cuba B
pag. 51



1127
Nuvola
pag. 52



1127B
Nuvola B
pag. 53



2109
Honey
pag. 54



2113
Tesa
pag. 55



2114
Nives
pag. 56



WC Slim
pag. 57

769 Cuba *slim*



versione con rosetta slim

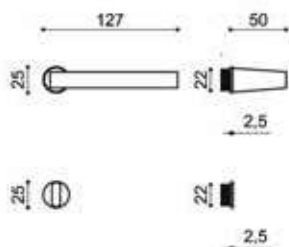

Rosetta standard:
Rslim rosetta slim

Varianti:
RslimY rosetta slim con foro yale
nottolino Wc abbinato da pag. 57

ATTENZIONE:
il sistema SLIM non prevede la molla di ritorno sulla maniglia, quindi è consigliato utilizzare una serratura adeguata.

finiture:
MCS maritech cromato satinato
MCR maritech cromato lucido

769B Cuba B *slim*



versione con rosetta slim

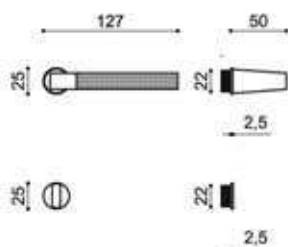

Rosetta standard:
Rslim rosetta slim

Varianti:
RslimY rosetta slim con foro yale
nottolino Wc abbinato da pag. 57

ATTENZIONE:
il sistema SLIM non prevede la
molla di ritorno sulla maniglia,
quindi è consigliato utilizzare
una serratura adeguata.

finiture:
MCR/CS maritech bi colore cromo/satinato

1127 Nuvola *slim*



versione con rosetta slim

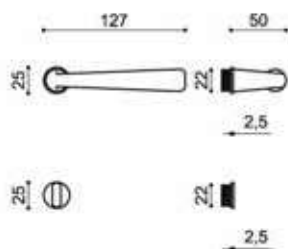

Rosetta standard:
Rslim rosetta slim

Varianti:
RslimY rosetta slim con foro yale
nottolino Wc abbinato da pag. 57

ATTENZIONE:
il sistema SLIM non prevede la molla di ritorno sulla maniglia, quindi è consigliato utilizzare una serratura adeguata.

finiture:
MCS maritech cromato satinato
MCR maritech cromato lucido

1127B Nuvola B *slim*



versione con rosetta slim

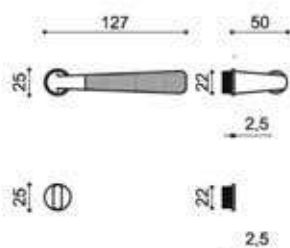

Rosetta standard:
Rslim rosetta slim

Varianti:
RslimY rosetta slim con foro yale
nottolino Wc abbinato da pag. 57

ATTENZIONE:
il sistema SLIM non prevede la
molla di ritorno sulla maniglia,
quindi è consigliato utilizzare
una serratura adeguata.

finiture:
MCR/CS maritech bi colore cromo/satinato

2109 Honey *slim*



versione con rosetta slim

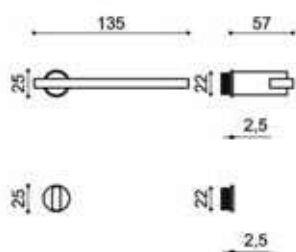

Rosetta standard:
Rslim rosetta slim

Varianti:
RslimY rosetta slim con foro yale
nottolino Wc abbinato da pag. 57

ATTENZIONE:
il sistema SLIM non prevede la molla di ritorno sulla maniglia, quindi è consigliato utilizzare una serratura adeguata.

finiture:
CS ottone cromato satinato
CR ottone cromato lucido
CR/CS ottone bi colore cromo/satinato

2113 Tesa *slim*



versione con rosetta slim

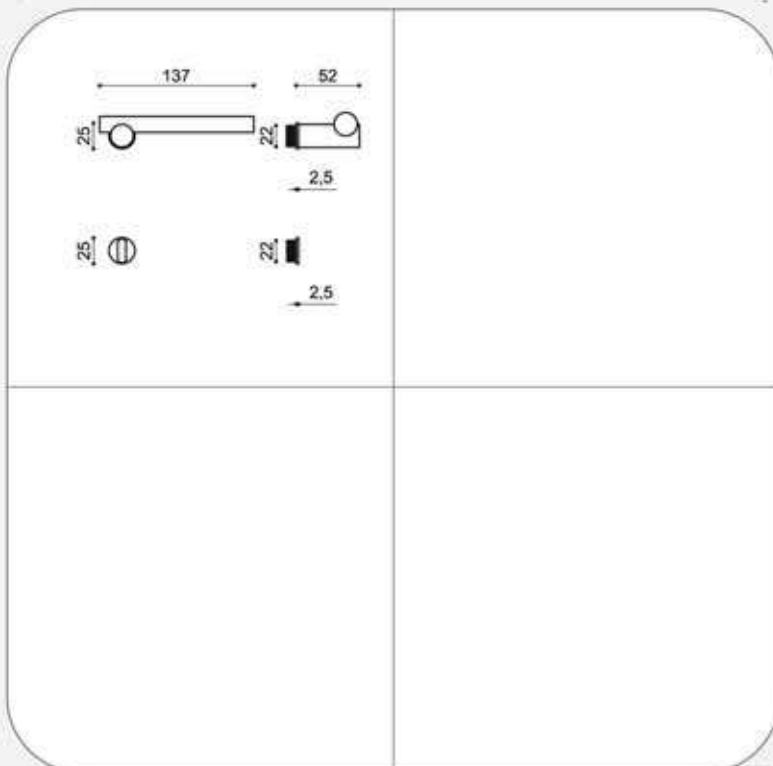

Rosetta standard:
Rslim rosetta slim

Varianti:
RslimY rosetta slim con foro yale
nottolino Wc abbinato da pag. 57

ATTENZIONE:
il sistema SLIM non prevede la molla di ritorno sulla maniglia, quindi è consigliato utilizzare una serratura adeguata.

finiture:
CS ottone cromato satinato
CR ottone cromato lucido
CR/CS ottone bi colore cromo/satinato

2114 Nives *slim*



versione con rosetta slim

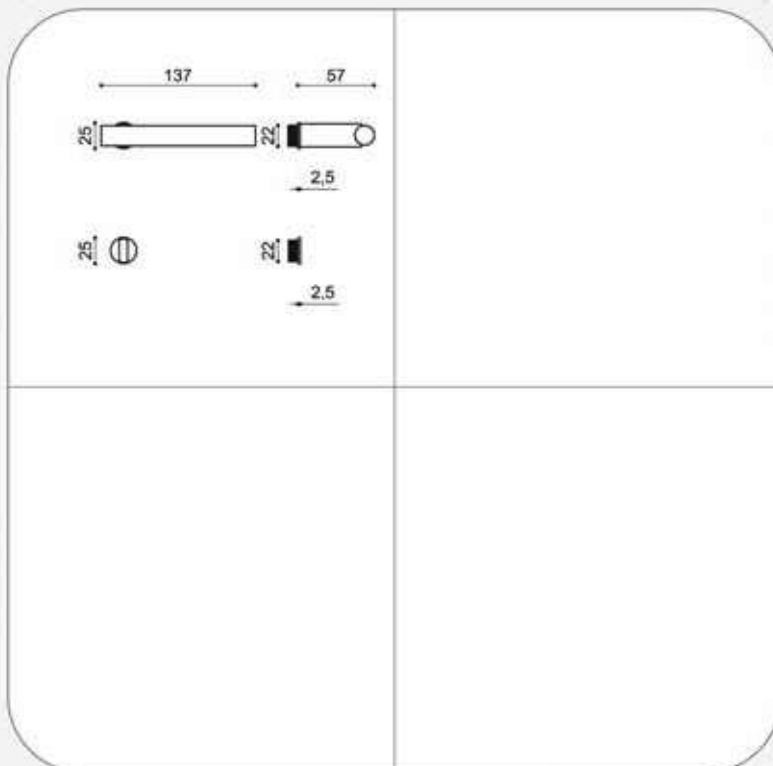

Rosetta standard:
Rslim rosetta slim

Varianti:
RslimY rosetta slim con foro yale
nottolino Wc abbinato da pag. 57

ATTENZIONE:
il sistema SLIM non prevede la molla di ritorno sulla maniglia, quindi è consigliato utilizzare una serratura adeguata.

finiture:
CS ottone cromato satinato
CR ottone cromato lucido
CR/CS ottone bi colore cromo/satinato

1735 *slim* Wc tondo con pom. a farfalla

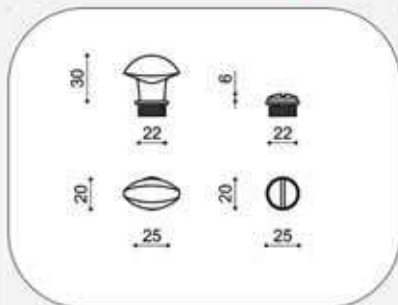

finiture:

CS ottone cromato satinato
CR ottone cromato lucido

MCS maritech cromato satinato
MCR maritech cromato lucido

1740 *slim* Wc tondo con pomolino alto

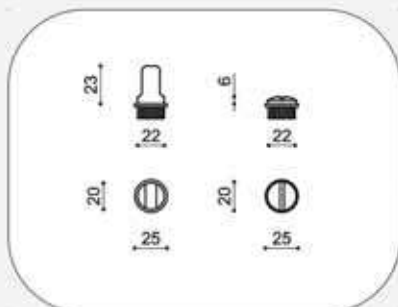

finiture:

CS ottone cromato satinato
CR ottone cromato lucido

MCS maritech cromato satinato
MCR maritech cromato lucido

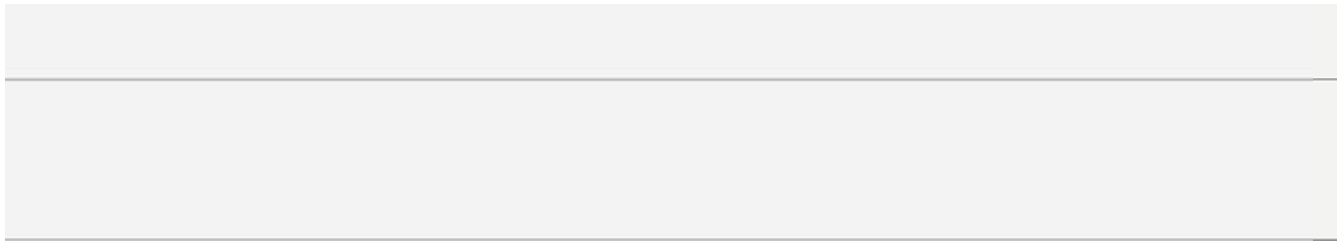

Maniglie su rosetta tonda premontata



766B
Spigola B
pag. 61



2114
Nives
pag. 71



1130
Kioto
pag. 62



2130
Marea
pag. 72



1770
Ginevra
pag. 63



2130B
Marea B
pag. 73



1776
Ottocento
pag. 64



2140
Meganisi
pag. 74



1777
Firenze
pag. 65



2147
Linzi
pag. 75



2109
Honey
pag. 68



2260
Sirio
pag. 76



2110B
Luxury B
pag. 67



2270B
Paris B
pag. 77



2111B
Prestige B
pag. 68



2271B
Scarlet B
pag. 78



2112
Space
pag. 69



2274B
Star B
pag. 79



766
Spigola
pag. 60



2113
Tesa
pag. 70



2275B
Adria B
pag. 80

766 Spigola



versione con rosetta tonda

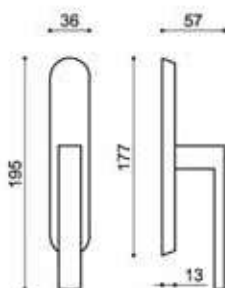
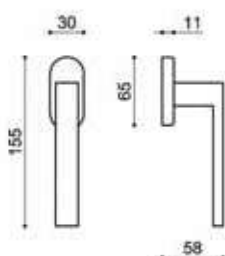
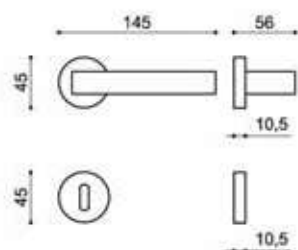

Rosetta standard:
RP45 rosetta tonda premontata d. 45 mm

Varianti:
RP50 rosetta tonda premontata d. 50 mm
RPO rosetta ovale premontata mm 30x65
nottolino Wc abbinato da pag. 320

Dry keep standard:
D dry keep ovale con mov. in metallo
7x42 mm con boccole art. 1672 pag. 364

Martellina standard:
placca art. P108 pag. 359 con movimento
rinforzato art. 1559 pag. 365

Cremonese standard:
placca art. P108 pag. 359
movimento intercambiabile art. 1551R pag.365

finiture:
MCS maritech cromato satinato
MCR maritech cromato lucido

766B Spigola B



versione con rosetta tonda

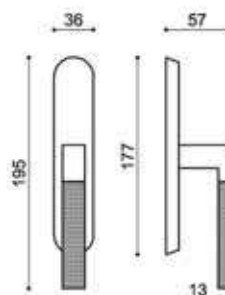
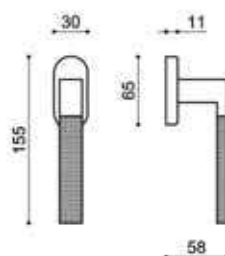
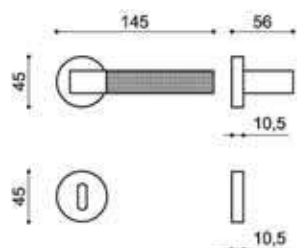

Rosetta standard:
RP45 rosetta tonda premontata d. 45 mm

Varianti:
RP50 rosetta tonda premontata d. 50 mm
RPO rosetta ovale premontata mm 30x65
nottolino Wc abbinato da pag. 320

Dry keep standard:
D dry keep ovale con mov. in metallo
7x42 mm con boccole art. 1672 pag. 364

Martellina standard:
placca art. P108 pag. 359 con movimento
rinforzato art. 1559 pag. 365

Cremonese standard:
placca art. P108 pag. 359
movimento intercambiabile art. 1551R pag.365

finiture:
MCR/CS maritech bi colore cromo/satinato

1130 Kioto

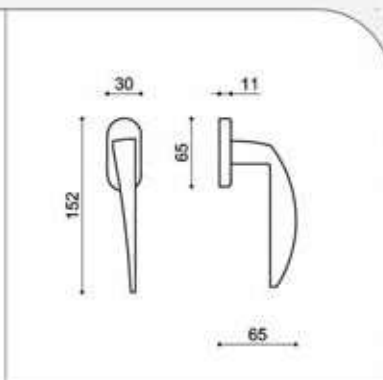
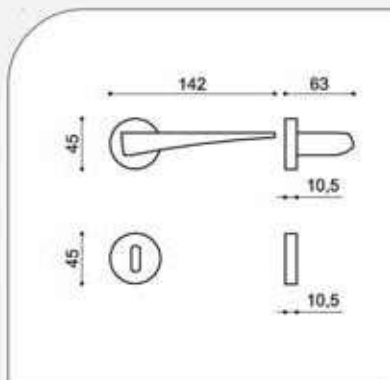

Rosetta standard:
RP45 rosetta tonda premontata d. 45 mm

Varianti:
RP50 rosetta tonda premontata d. 50 mm
RPO rosetta ovale premontata mm 30x65
 nottolino Wc abbinato da pag. 320

Dry keep standard:
D dry keep ovale con mov. in metallo
 7x42 mm con boccole art. 1672 pag. 364

Martellina standard:
 placca art. P108 pag. 359 con movimento
 rinforzato art. 1559 pag. 365

Cremonese standard:
 placca art. P108 pag. 359
 movimento intercambiabile art. 1551R pag.365

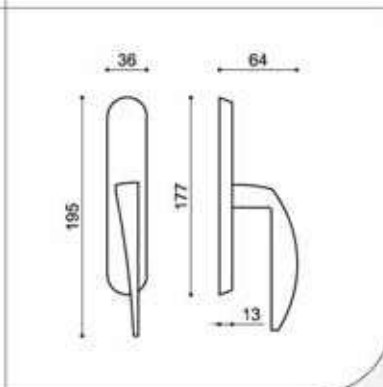

finiture:
MCS maritech cromato satinato

1770 Ginevra

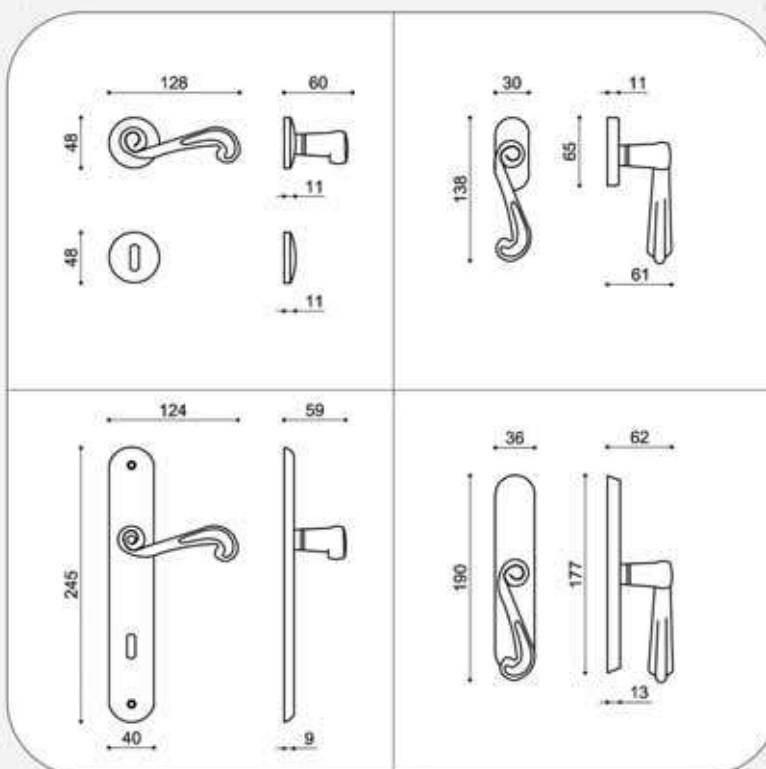

Rosetta standard:
RB rosetta bombata premontata d. 48 mm

Varianti:
RPO rosetta ovale premontata mm 30x65
 nottolino Wc abbinato da pag. 320

Dry keep standard:
D dry keep ovale con mov. in metallo
 7x42 mm con boccole art. 1672 pag. 364

Piacca standard:
 distanza 70/90/yale/Wc art. P102 pag. 358

Martellina standard:
 placca art. P108 pag. 359 con movimento
 rinforzato art. 1559 pag. 365

Cremonese standard:
 placca art. P108 pag. 359
 movimento intercambiabile art. 1551R pag.365

finiture:
OLV ottone lucido verniciato
ANT ottone bronzo antico
ORO ottone oro antico
ARG ottone argento antico
RAM ottone ramato antico

1776 Ottocento

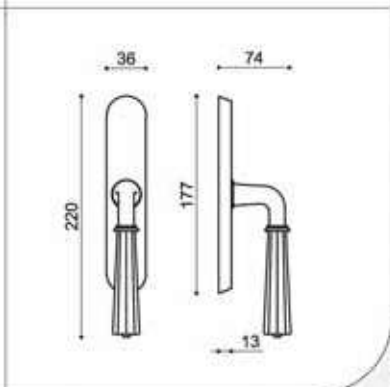
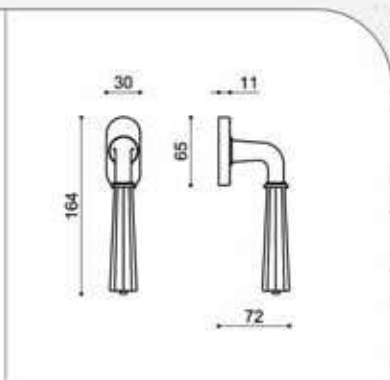
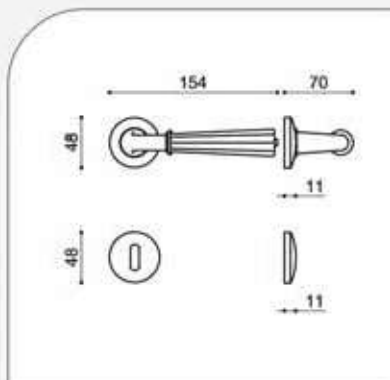

Rosetta standard:
RB rosetta bombata premontata d. 48 mm

Varianti:
RPO rosetta ovale premontata mm 30x65
 nottolino Wc abbinato da pag. 320

Dry keep standard:
D dry keep ovale con mov. in metallo
 7x42 mm con boccole art. 1672 pag. 364

Martellina standard:
 placca art. P108 pag. 359 con movimento
 rinforzato art. 1559 pag. 365

Cremonese standard:
 placca art. P108 pag. 359
 movimento intercambiabile art. 1551R pag.365

finiture:
ANT ottone bronzo antico
ORO ottone oro antico
ARG ottone argento antico

1777 Firenze

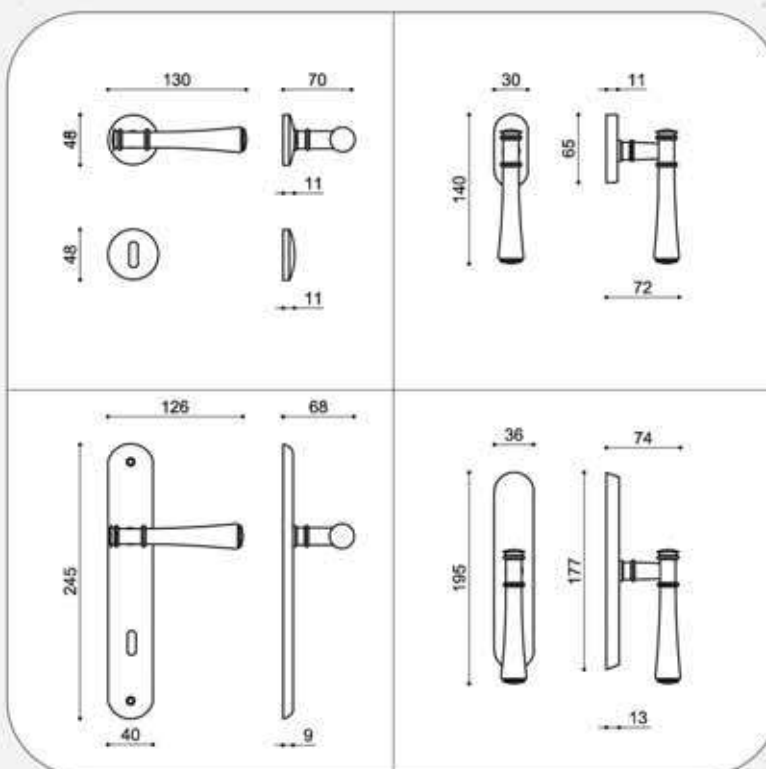

Rosetta standard:
RB rosetta bombata premontata d. 48 mm

Varianti:
RPO rosetta ovale premontata mm 30x65
 nottolino Wc abbinato da pag. 320

Dry keep standard:
D dry keep ovale con mov. in metallo
 7x42 mm con boccole art. 1672 pag. 364

Piacca standard:
 distanza 70/90/yale/Wc art. P102 pag. 358

Martellina standard:
 placca art. P108 pag. 359 con movimento
 rinforzato art. 1559 pag. 365

Cremonese standard:
 placca art. P108 pag. 359
 movimento intercambiabile art. 1551R pag.365

finiture:
ANT ottone bronzo antico
ORO ottone oro antico
ARG ottone argento antico

2109 Honey



versione con rosetta tonda

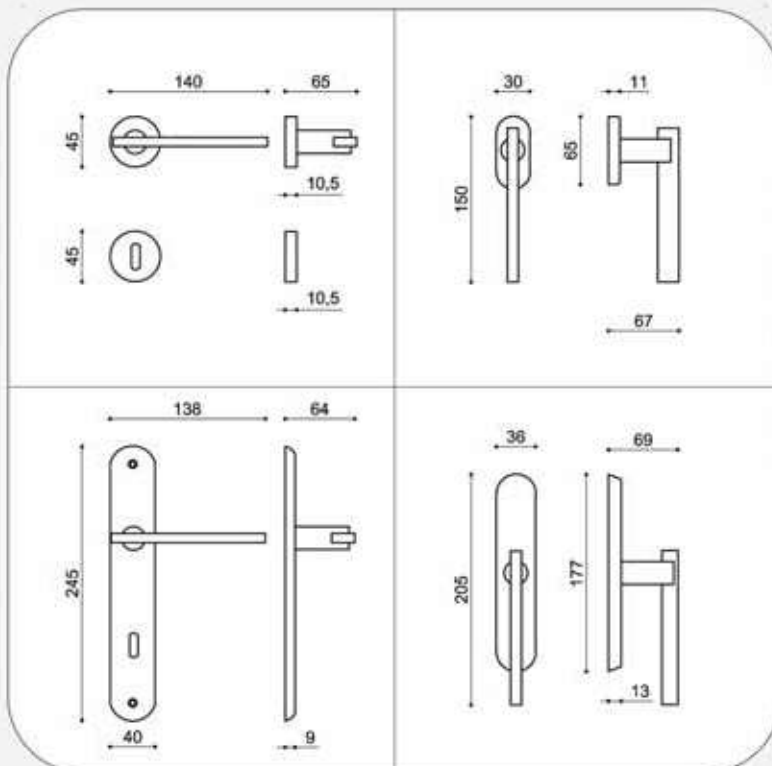

Rosetta standard:
RP45 rosetta tonda premontata d. 45 mm

Varianti:
RPO rosetta ovale premontata mm 30x65
nottolino Wc abbinato da pag. 320

Dry keep standard:
D dry keep ovale con mov. in metallo
7x42 mm con boccole art. 1672 pag. 364

Placca standard:
distanza 70/90/yale/Wc art. P102 pag. 358

Martellina standard:
placca art. P108 pag. 359 con movimento
rinforzato art. 1559 pag. 365

Cremonese standard:
placca art. P108 pag. 359
movimento intercambiabile art. 1551R pag.365

finiture:
CS ottone cromato satinato
CR ottone cromato lucido
CR/CS ottone bi colore cromo/satinato

2110B Luxury B



versione con rosetta tonda

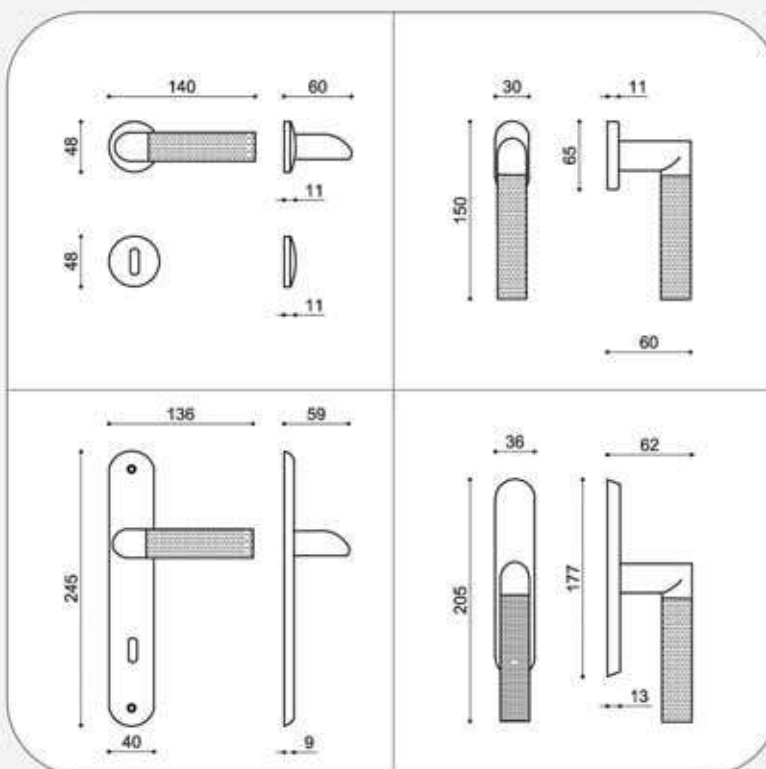

Rosetta standard:
RB rosetta bombata premontata d. 48 mm

Varianti:
RP50 rosetta tonda premontata d. 50 mm
RPO rosetta ovale premontata mm 30x65
 nottolino Wc abbinato da pag. 320

Dry keep standard:
D dry keep ovale con mov. in metallo
 7x42 mm con boccole art. 1672 pag. 364

Placca standard:
 distanza 70/90/yale/Wc art. P102 pag. 358

Martellina standard:
 placca art. P108 pag. 359 con movimento rinforzato art. 1559 pag. 365

Cremonese standard:
 placca art. P108 pag. 359
 movimento intercambiabile art. 1551R pag.365

finiture:
OLV/OLS ottone bi colore lucido/satinato
CR/CS ottone bi colore cromo/satinato

2111B Prestige B



versione con rosetta tonda

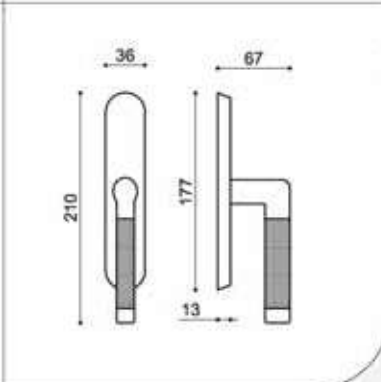
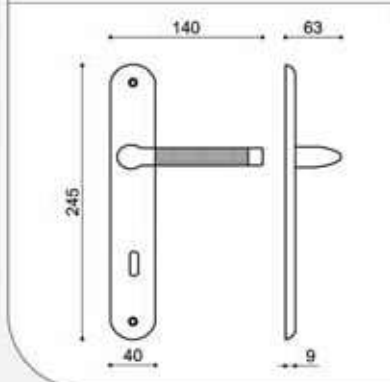
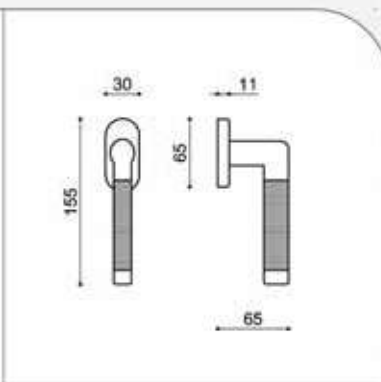
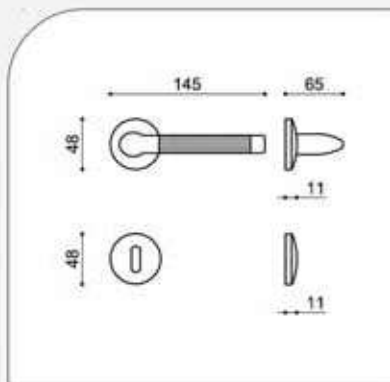

Rosetta standard:
RB rosetta bombata premontata d. 48 mm

Varianti:
RP50 rosetta tonda premontata d. 50 mm
RPO rosetta ovale premontata mm 30x65
 nottolino Wc abbinato da pag. 320

Dry keep standard:
D dry keep ovale con mov. in metallo
 7x42 mm con boccole art. 1672 pag. 364

Placca standard:
 distanza 70/90/yale/Wc art. P102 pag. 358

Martellina standard:
 placca art. P108 pag. 359 con movimento rinforzato art. 1559 pag. 365

Cremonese standard:
 placca art. P108 pag. 359
 movimento intercambiabile art. 1551R pag.365

finiture:
OLV/OLS ottone bi colore lucido/satinato
CR/CS ottone bi colore cromo/satinato

2112 Space



versione con rosetta tonda

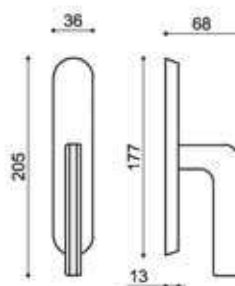
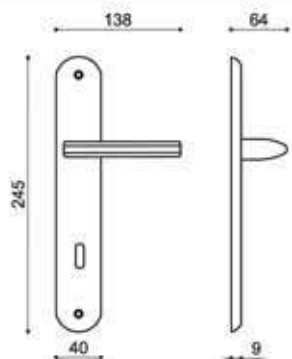
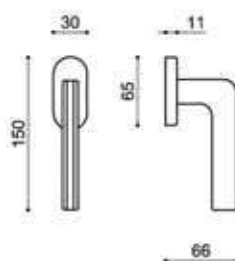
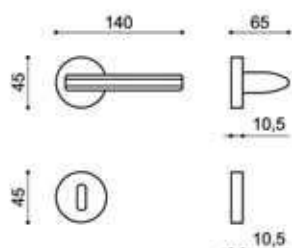

Rosetta standard:
RP45 rosetta tonda premontata d. 45 mm

Varianti:
RP50 rosetta tonda premontata d. 50 mm
RPO rosetta ovale premontata mm 30x65
nottolino Wc abbinato da pag. 320

Dry keep standard:
D dry keep ovale con mov. in metallo
7x42 mm con boccole art. 1672 pag. 364

Placca standard:
distanza 70/90/yale/Wc art. P102 pag. 358

Martellina standard:
placca art. P108 pag. 359 con movimento
rinforzato art. 1559 pag. 365

Cremonese standard:
placca art. P108 pag. 359
movimento intercambiabile art. 1551R pag.365

finiture:
OLV ottone lucido verniciato
CS ottone cromato satinato
CR ottone cromato lucido

2113 Tesa

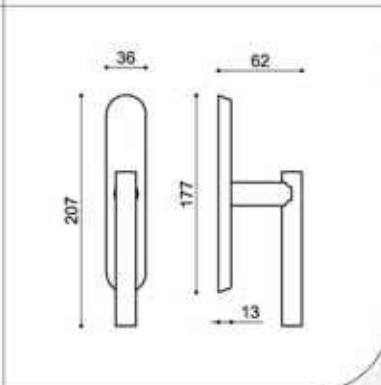
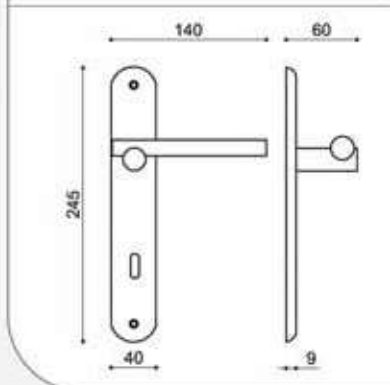
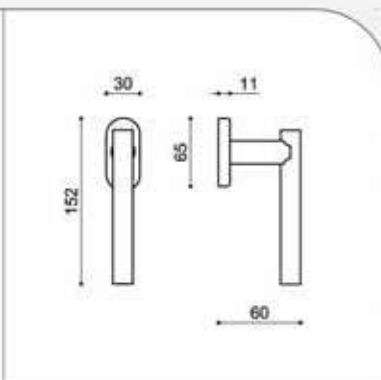
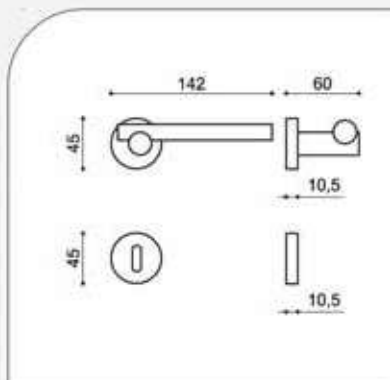

Rosetta standard:
RP45 rosetta tonda premontata d. 45 mm

Varianti:
RP50 rosetta tonda premontata d. 50 mm
RPO rosetta ovale premontata mm 30x65
nottolino Wc abbinato da pag. 320

Dry keep standard:
D dry keep ovale con mov. in metallo
7x42 mm con boccole art. 1672 pag. 364

Placca standard:
distanza 70/90/yale/Wc art. P102 pag. 358

Martellina standard:
placca art. P108 pag. 359 con movimento
rinforzato art. 1559 pag. 365

Cremonese standard:
placca art. P108 pag. 359
movimento intercambiabile art. 1551R pag.365

finiture:
CS ottone cromato satinato
CR ottone cromato lucido
CR/CS ottone bi colore cromo/satinato

2114 Nives

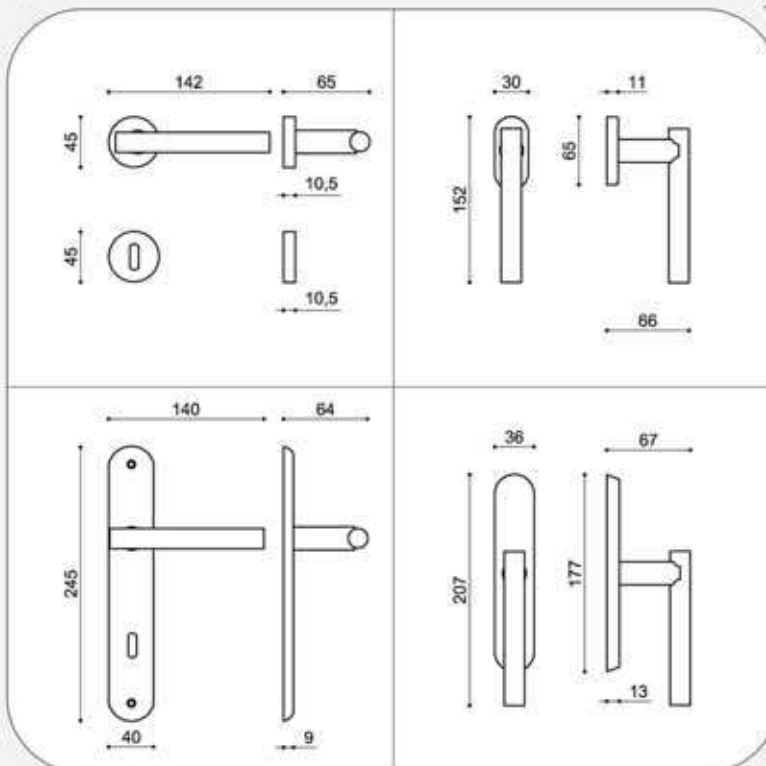

Rosetta standard:
RP45 rosetta tonda premontata d. 45 mm

Varianti:
RP50 rosetta tonda premontata d. 50 mm
RPO rosetta ovale premontata mm 30x65
nottolino Wc abbinato da pag. 320

Dry keep standard:
D dry keep ovale con mov. in metallo
7x42 mm con boccole art. 1672 pag. 364

Placca standard:
distanza 70/90/yale/Wc art. P102 pag. 358

Martellina standard:
placca art. P108 pag. 359 con movimento
rinforzato art. 1559 pag. 365

Cremonese standard:
placca art. P108 pag. 359
movimento intercambiabile art. 1551R pag.365

finiture:
CS ottone cromato satinato
CR ottone cromato lucido
CR/CS ottone bi colore cromo/satinato

2130 Marea

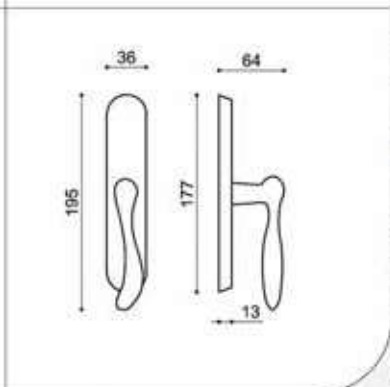
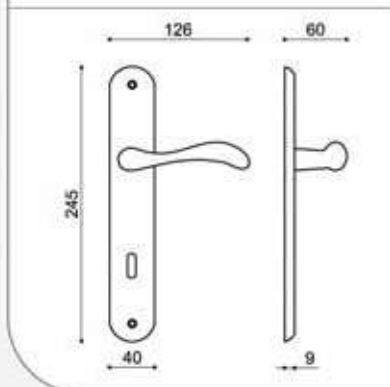
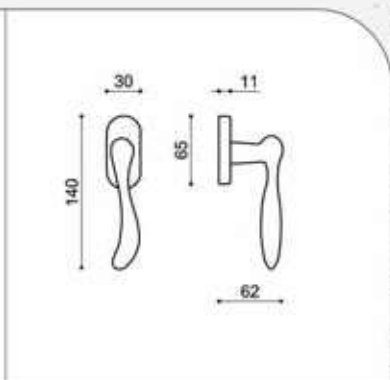
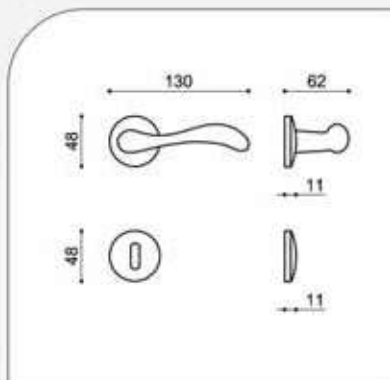

Rosetta standard:
RB rosetta bombata premontata d. 48 mm

Varianti:
RPO rosetta ovale premontata mm 30x65
 nottolino Wc abbinato da pag. 320

Dry keep standard:
D dry keep ovale con mov. in metallo
 7x42 mm con boccole art. 1672 pag. 364

Placca standard:
 distanza 70/90/yale/Wc art. P102 pag. 358

Martellina standard:
 placca art. P108 pag. 359 con movimento
 rinforzato art. 1559 pag. 365

Cremonese standard:
 placca art. P108 pag. 359
 movimento intercambiabile art. 1551R pag.365

finiture:
PVD ottone con trattamento PVD

- OLV** ottone lucido verniciato
- SV** ottone satinato verniciato
- CS** ottone cromato satinato
- CR** ottone cromato lucido
- ANT** ottone bronzo antico
- ORO** ottone oro antico
- ARG** ottone argento antico
- RAM** ottone ramato antico
- BG** ottone bronzato graffiato

2130B Marea B

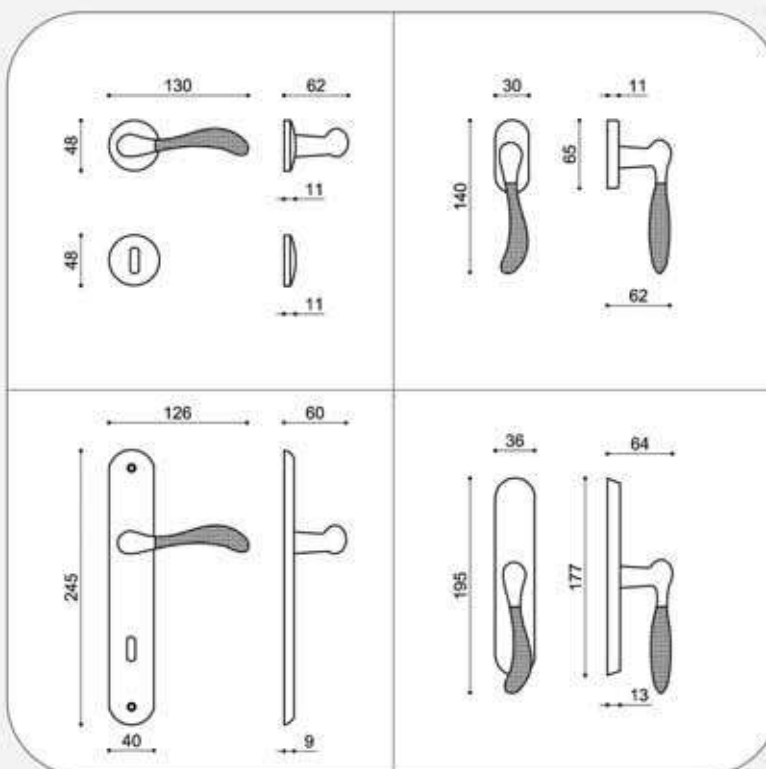

Rosetta standard:
RB rosetta bombata premontata d. 48 mm

Varianti:
RPO rosetta ovale premontata mm 30x65
 nottolino Wc abbinato da pag. 320

Dry keep standard:
D dry keep ovale con mov. in metallo
 7x42 mm con boccole art. 1672 pag. 364

Placca standard:
 distanza 70/90/yale/Wc art. P102 pag. 358

Martellina standard:
 placca art. P108 pag. 359 con movimento
 rinforzato art. 1559 pag. 365

Cremonese standard:
 placca art. P108 pag. 359
 movimento intercambiabile art. 1551R pag.365

finiture:
PVD/SAT ottone bi colore con tratt. PVD/SAT

OLV/OLS ottone bi colore lucido/satinato
CR/CS ottone bi colore cromo/satinato

2140 Meganisi

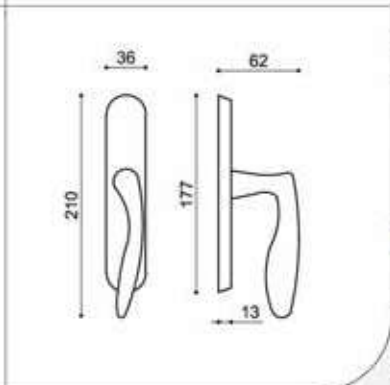
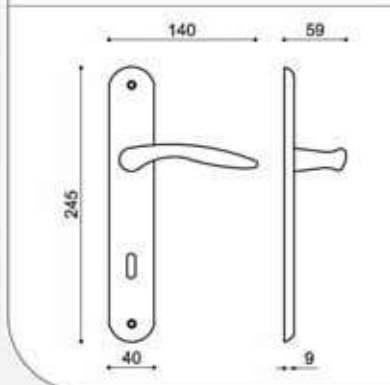
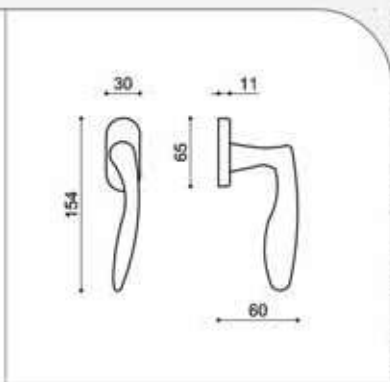
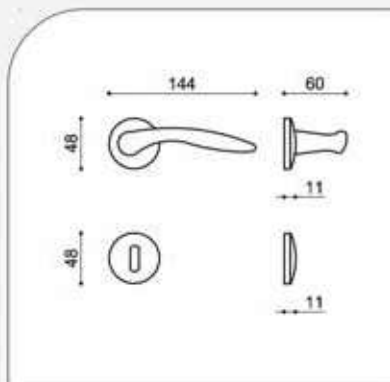

Rosetta standard:
RB rosetta bombata premontata d. 48 mm

Varianti:
RPO rosetta ovale premontata mm 30x65
 nottolino Wc abbinato da pag. 320

Dry keep standard:
D dry keep ovale con mov. in metallo
 7x42 mm con boccole art. 1672 pag. 364

Placca standard:
 distanza 70/90/yale/Wc art. P102 pag. 358

Martellina standard:
 placca art. P108 pag. 359 con movimento
 rinforzato art. 1559 pag. 365

Cremonese standard:
 placca art. P108 pag. 359
 movimento intercambiabile art. 1551R pag.365

finiture:
PVD ottone con trattamento PVD

OLV ottone lucido verniciato
SV ottone satinato verniciato
CS ottone cromato satinato
CR ottone cromato lucido
BG ottone bronzato graffiato

2147 Linzi



versione con rosetta tonda

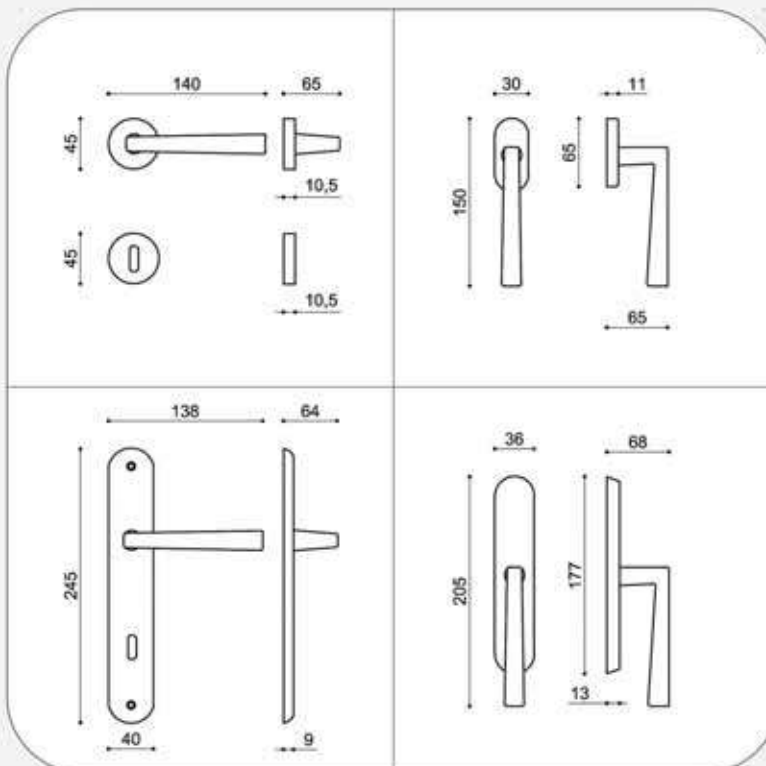

Rosetta standard:
RP45 rosetta tonda premontata d. 45 mm

Varianti:
RP50 rosetta tonda premontata d. 50 mm
RPO rosetta ovale premontata mm 30x65
nottolino Wc abbinato da pag. 320

Dry keep standard:
D dry keep ovale con mov. in metallo
7x42 mm con boccole art. 1672 pag. 364

Placca standard:
distanza 70/90/yale/Wc art. P102 pag. 358

Martellina standard:
placca art. P108 pag. 359 con movimento
rinforzato art. 1559 pag. 365

Cremonese standard:
placca art. P108 pag. 359
movimento intercambiabile art. 1551R pag.365

finiture:
OLV ottone lucido verniciato
CS ottone cromato satinato
CR ottone cromato lucido

2260 Sirio

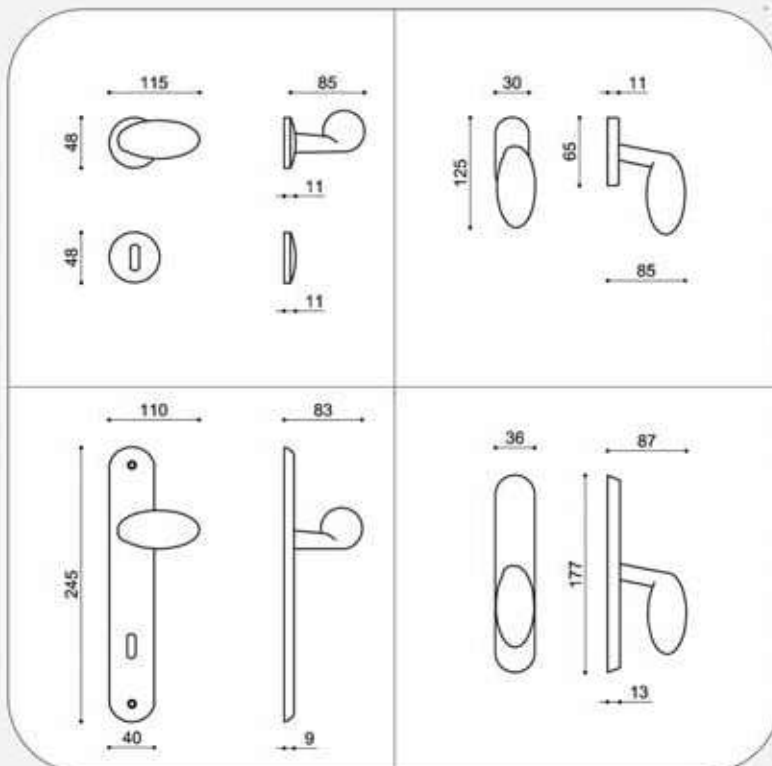

Rosetta standard:
RB rosetta bombata premontata d. 48 mm

Varianti:
RPO rosetta ovale premontata mm 30x65
 nottolino Wc abbinato da pag. 320

Dry keep standard:
D dry keep ovale con mov. in metallo
 7x42 mm con boccole art. 1672 pag. 364

Placca standard:
 distanza 70/90/yale/Wc art. P102 pag. 358

Martellina standard:
 placca art. P108 pag. 359 con movimento
 rinforzato art. 1559 pag. 365

Cremonese standard:
 placca art. P108 pag. 359
 movimento intercambiabile art. 1551R pag.365

finiture:
PVD ottone con trattamento PVD

OLV ottone lucido verniciato
SV ottone satinato verniciato
CS ottone cromato satinato
CR ottone cromato lucido
ANT ottone bronzo antico
ORO ottone oro antico
ARG ottone argento antico
BG ottone bronzato graffiato

2270B Paris B

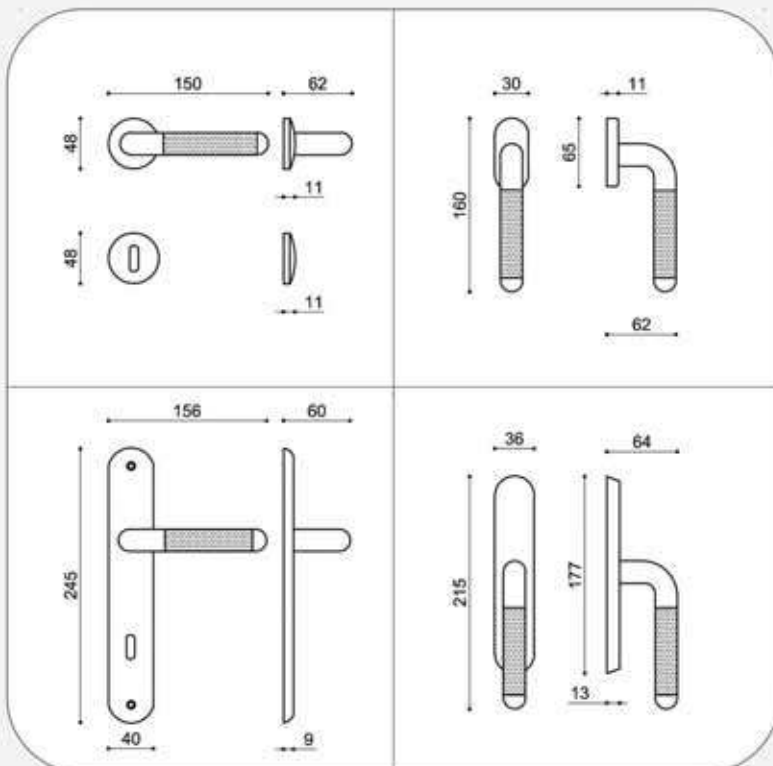

Rosetta standard:
RB rosetta bombata premontata d. 48 mm

Varianti:
RP50 rosetta tonda premontata d. 50 mm
RPO rosetta ovale premontata mm 30x65
 nottolino Wc abbinato da pag. 320

Dry keep standard:
D dry keep ovale con mov. in metallo
 7x42 mm con boccole art. 1672 pag. 364

Placca standard:
 distanza 70/90/yale/Wc art. P102 pag. 358

Martellina standard:
 placca art. P108 pag. 359 con movimento rinforzato art. 1559 pag. 365

Cremonese standard:
 placca art. P108 pag. 359
 movimento intercambiabile art. 1551R pag.365

finiture:
CR/CS ottone bi colore cromo/satinato

2271B Scarlet B

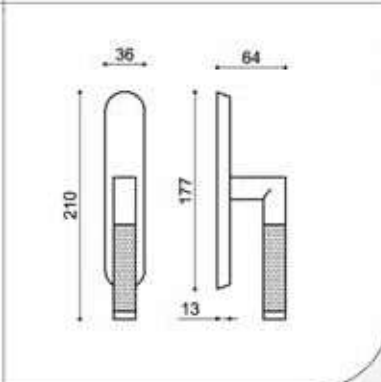
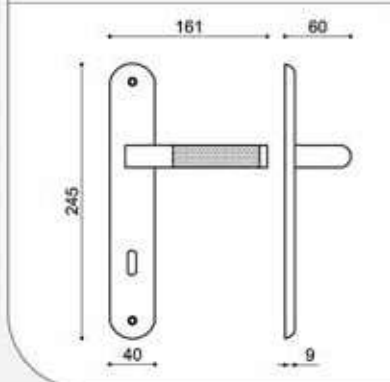
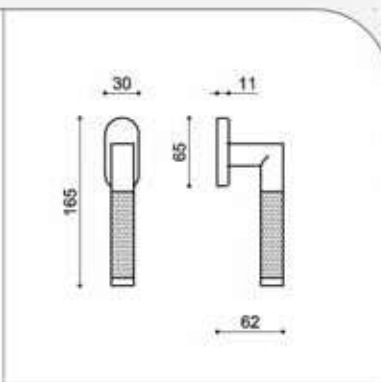
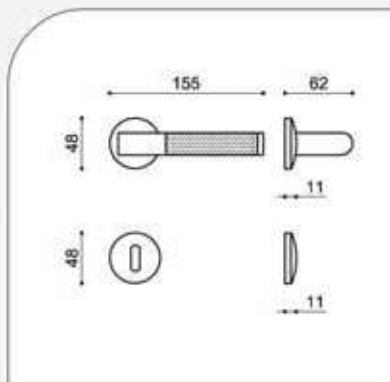

Rosetta standard:
RB rosetta bombata premontata d. 48 mm

Varianti:
RP50 rosetta tonda premontata d. 50 mm
RPO rosetta ovale premontata mm 30x65
 nottolino Wc abbinato da pag. 320

Dry keep standard:
D dry keep ovale con mov. in metallo
 7x42 mm con boccole art. 1672 pag. 364

Placca standard:
 distanza 70/90/yale/Wc art. P102 pag. 358

Martellina standard:
 placca art. P108 pag. 359 con movimento rinforzato art. 1559 pag. 365

Cremonese standard:
 placca art. P108 pag. 359
 movimento intercambiabile art. 1551R pag.365

finiture:
CR/CS ottone bi colore cromo/satinato

2274B Star B

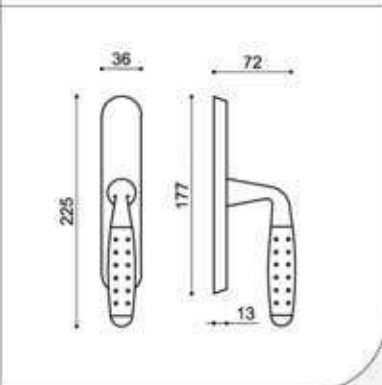
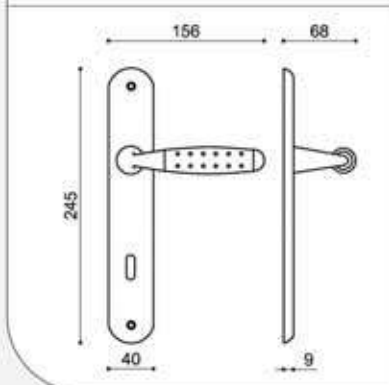
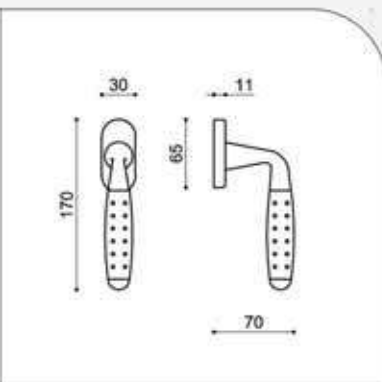
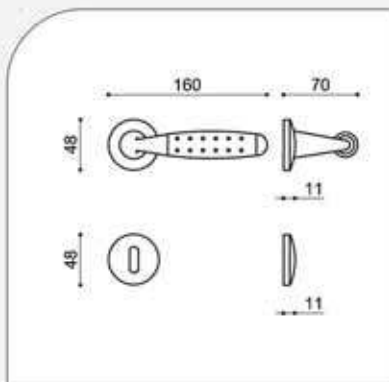

Rosetta standard:
RB rosetta bombata premontata d. 48 mm

Varianti:
RP50 rosetta tonda premontata d. 50 mm
RPO rosetta ovale premontata mm 30x65
 nottolino Wc abbinato da pag. 320

Dry keep standard:
D dry keep ovale con mov. in metallo
 7x42 mm con boccole art. 1672 pag. 364

Placca standard:
 distanza 70/90/yale/Wc art. P102 pag. 358

Martellina standard:
 placca art. P108 pag. 359 con movimento rinforzato art. 1559 pag. 365

Cremonese standard:
 placca art. P108 pag. 359
 movimento intercambiabile art. 1551R pag.365

finiture:
OLV/OLS ottone bi colore lucido/satinato
CR/CS ottone bi colore cromo/satinato

2275B Adria B

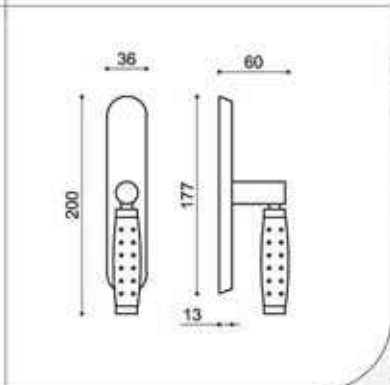
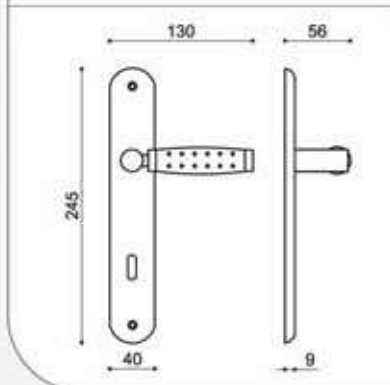
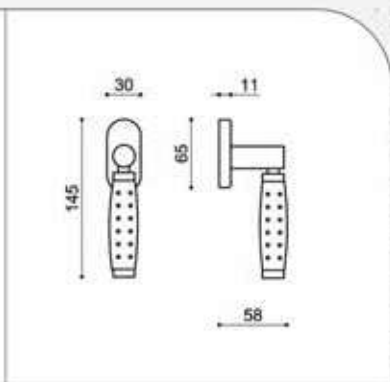
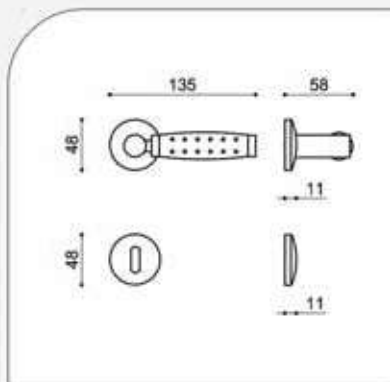

Rosetta standard:
RB rosetta bombata premontata d. 48 mm

Varianti:
RP50 rosetta tonda premontata d. 50 mm
RPO rosetta ovale premontata mm 30x65
 nottolino Wc abbinato da pag. 320

Dry keep standard:
D dry keep ovale con mov. in metallo
 7x42 mm con boccole art. 1672 pag. 364

Placca standard:
 distanza 70/90/yale/Wc art. P102 pag. 358

Martellina standard:
 placca art. P108 pag. 359 con movimento rinforzato art. 1559 pag. 365

Cremonese standard:
 placca art. P108 pag. 359
 movimento intercambiabile art. 1551R pag.365

finiture:
OLV/OLS ottone bi colore lucido/satinato
CR/CS ottone bi colore cromo/satinato

Riferimenti rosette tonde premontate

Placca per maniglia

pagina 358

Placca per martellina/cremonese

pagina 359

Rosette e bocchette tonde diametro 45 mm

pagina 361

Rosette e bocchette tonde diametro 50 mm

pagina 360

Rosette e bocchette tonde bombate

pagina 360















Rosette e bocchette ovali

pagina 361

Nottolini Wc tondi, bombati e ovali

da pagina 320



- | | | |
|---|--|--|
| |  | 160
Bastone
<i>pag. 88</i> |
| |  | 160P
Bastone Pesante
<i>pag. 89</i> |
| |  | 370
Chiara
<i>pag. 90</i> |
| |  | 380
Cometa
<i>pag. 91</i> |
| |  | 450
Elisa
<i>pag. 92</i> |
| |  | 450B
Elisa B
<i>pag. 93</i> |
|  | 148
Miriam
<i>pag. 84</i> |  |
|  | 148B
Miriam B
<i>pag. 85</i> |  |
|  | 150
Adry
<i>pag. 86</i> |  |
|  | 151
Modial
<i>pag. 87</i> |  |
| | | 580
Epoca
<i>pag. 94</i> |
| | | 580B
Epoca B
<i>pag. 95</i> |
| | | 690
Opera
<i>pag. 96</i> |
| | | 691
Futura
<i>pag. 97</i> |

Maniglie su rosetta tonda



755
Antea
pag. 98



1062B
Luna B
pag. 108



1778
Torino
pag. 118



755B
Antea B
pag. 99



1110
Giada
pag. 109



1779
Viareggio
pag. 119



765
Minerva
pag. 100



1125
Rugiada
pag. 110



1790
Sofia
pag. 120



765B
Minerva B
pag. 101



1126
Sidney
pag. 111



1791
Diamantea
pag. 121



769
Cuba
pag. 102



1127
Nuvola
pag. 112



1792
Camelia
pag. 122



769B
Cuba B
pag. 103



1127B
Nuvola B
pag. 113



1793
Scalea
pag. 123



1050
Onda
pag. 104



1128
Asia
pag. 114



179
CB collo basso
pag. 124



1055
Ines
pag. 105



1129
Arianna
pag. 115



164
Anello salva muro
pag. 125



1060
Alfa
pag. 106



1260
Uovo
pag. 116



161
Ovalino MP
pag. 126



1060B
Alfa B
pag. 107



1775
Aurelia
pag. 117



161T
Ovalino MP
pag. 127

148 Miriam

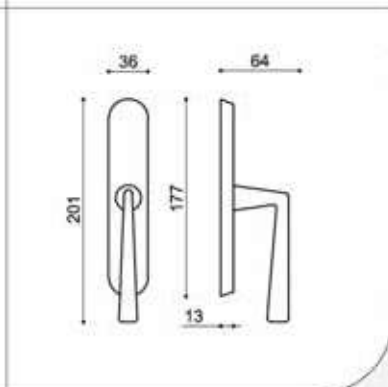
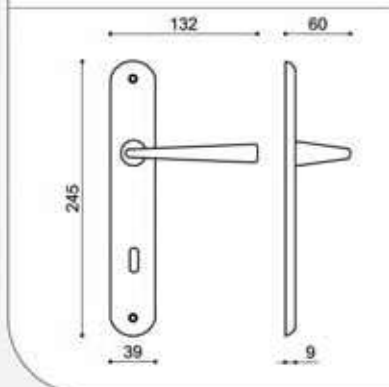
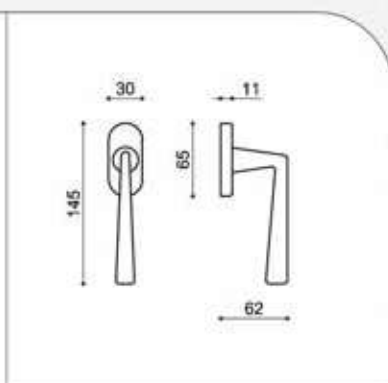
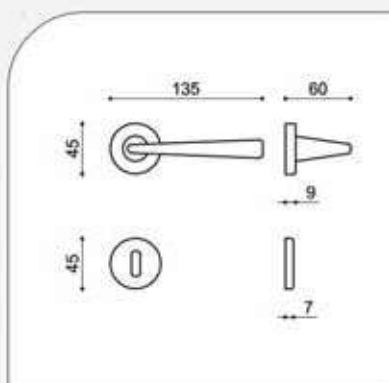

Rosetta standard:
R45 rosetta tonda d. 45 mm

Varianti:
R50 rosetta tonda d. 50 mm
RO rosetta ovale mm 30x60
nottolino Wc abbinato da pag. 320

Dry keep standard:
D dry keep ovale con mov. in metallo
7x42 mm con boccole art. 1672 pag. 364

Placca standard:
distanza 70/90/yale/Wc art. P102 pag. 358

Martellina standard:
placca art. P108 pag. 359 con movimento
rinforzato art. 1559 pag. 365

Cremonese standard:
placca art. P108 pag. 359
movimento intercambiabile art. 1551R pag.365

finiture:
OLV ottone lucido verniciato
CS ottone cromato satinato
CR ottone cromato lucido
BG ottone bronzato graffiato

148B Miriam B

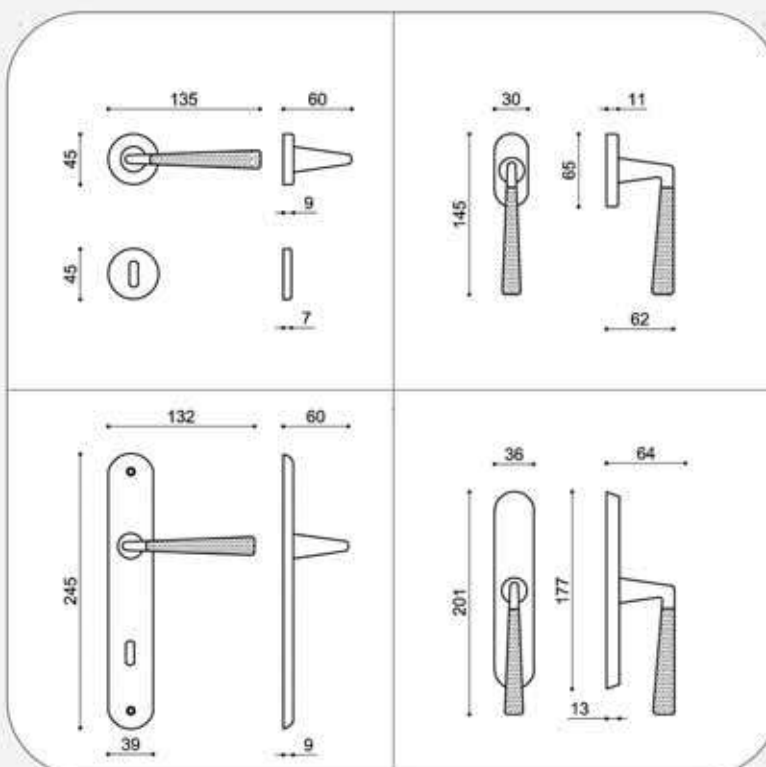

Rosetta standard:
R45 rosetta tonda d. 45 mm

Varianti:
R50 rosetta tonda d. 50 mm
RO rosetta ovale mm 30x60
nottolino Wc abbinato da pag. 320

Dry keep standard:
D dry keep ovale con mov. in metallo
7x42 mm con boccole art. 1672 pag. 364

Placca standard:
distanza 70/90/yale/Wc art. P102 pag. 358

Martellina standard:
placca art. P108 pag. 359 con movimento
rinforzato art. 1559 pag. 365

Cremonese standard:
placca art. P108 pag. 359
movimento intercambiabile art. 1551R
pag.365

finiture:
OLV/OLS ottone bi colore lucido/satinato
CR/CS ottone bi colore cromo/satinato
BR/BG ottone bi colore bronzo/graffiato

150 Adry

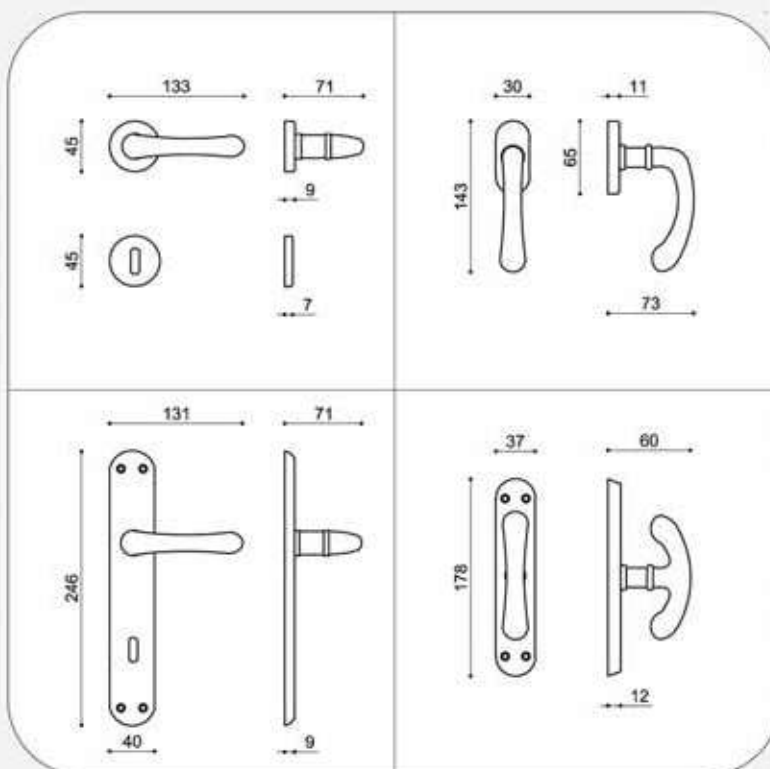
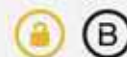

Rosetta standard:
R45 rosetta tonda d. 45 mm

Varianti:
R50 rosetta tonda d. 50 mm
RO rosetta ovale mm 30x60
nottolino Wc abbinato da pag. 320

Dry keep standard:
D dry keep ovale con mov. in metallo
7x42 mm con boccole art. 1672 pag. 364

Placca standard:
distanza 70/90/yale/Wc art. P101 pag. 358

Martellina standard:
placca art. P106 pag. 359 con quadro 7

Cremonese standard:
placca art. P106 pag. 359
movimento intercambiabile art. 1551 pag.365

finiture:
OLV ottone lucido verniciato
SV ottone satinato verniciato
LSV ottone lucido satinato verniciato
CS ottone cromato satinato
CR ottone cromato lucido
ANT ottone bronzo antico
BG ottone bronzato graffiato
BS ottone bronzato sfumato

151 Mondial

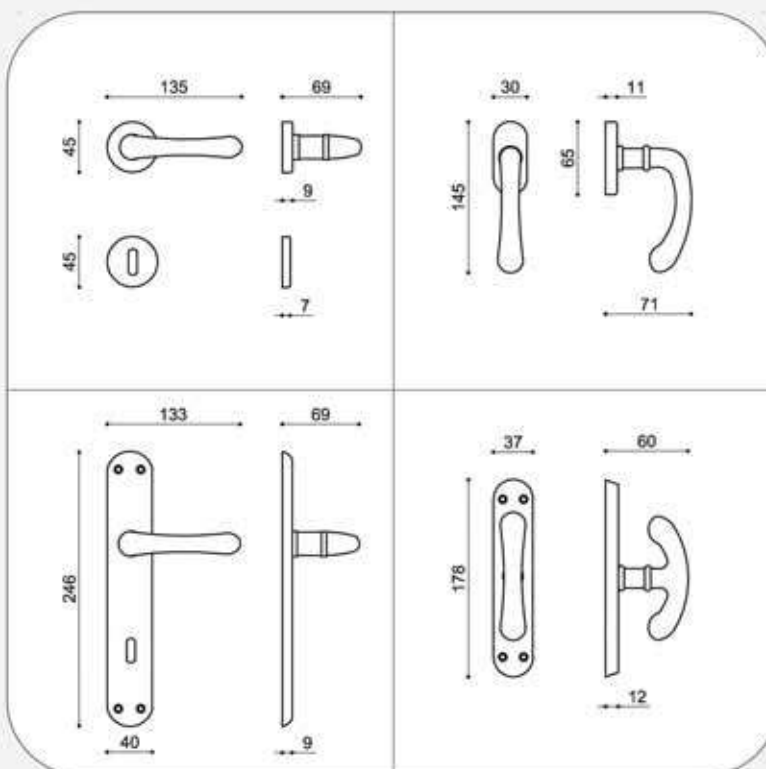

Rosetta standard:
R45 rosetta tonda d. 45 mm

Varianti:
R50 rosetta tonda d. 50 mm
RO rosetta ovale mm 30x60
nottolino Wc abbinato da pag. 320

Dry keep standard:
D dry keep ovale con mov. in metallo
7x42 mm con boccole art. 1672 pag. 364

Placca standard:
distanza 70/90/yale/Wc art. P101 pag. 358

Martellina standard:
placca art. P106 pag. 359 con quadro 7

Cremonese standard:
placca art. P106 pag. 359
movimento intercambiabile art. 1551 pag.365

finiture:
OLV ottone lucido verniciato
LSV ottone lucido satinato verniciato
CS ottone cromato satinato
BG ottone bronzato graffiato
BS ottone bronzato sfumato

160 Bastone

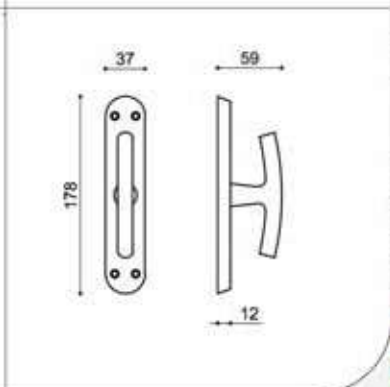
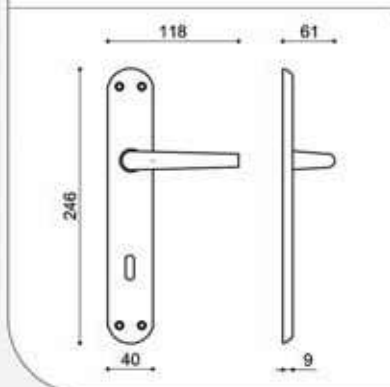
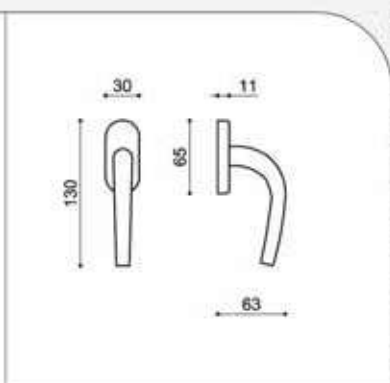
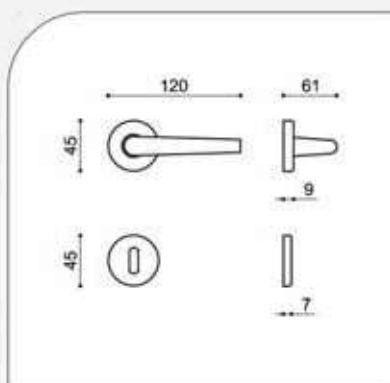

Rosetta standard:
R45 rosetta tonda d. 45 mm

Varianti:
R50 rosetta tonda d. 50 mm
RO rosetta ovale mm 30x60
nottolino Wc abbinato da pag. 320

Dry keep standard:
D dry keep ovale con mov. in metallo
7x42 mm con boccole art. 1672 pag. 364

Placca standard:
distanza 70/90/yale/Wc art. P102 pag. 358

Martellina standard:
placca art. P106 pag. 359 con quadro 7

Cremonese standard:
placca art. P106 pag. 359
movimento intercambiabile art. 1551 pag.365

finiture:
OLV ottone lucido verniciato
SV ottone satinato verniciato
CS ottone cromato satinato
CR ottone cromato lucido
BG ottone bronzato graffiato

MORO maritech oro lucido
MCS maritech cromato satinato
MCR maritech cromato lucido
MBG maritech bronzato graffiato

160P Bastone pesante

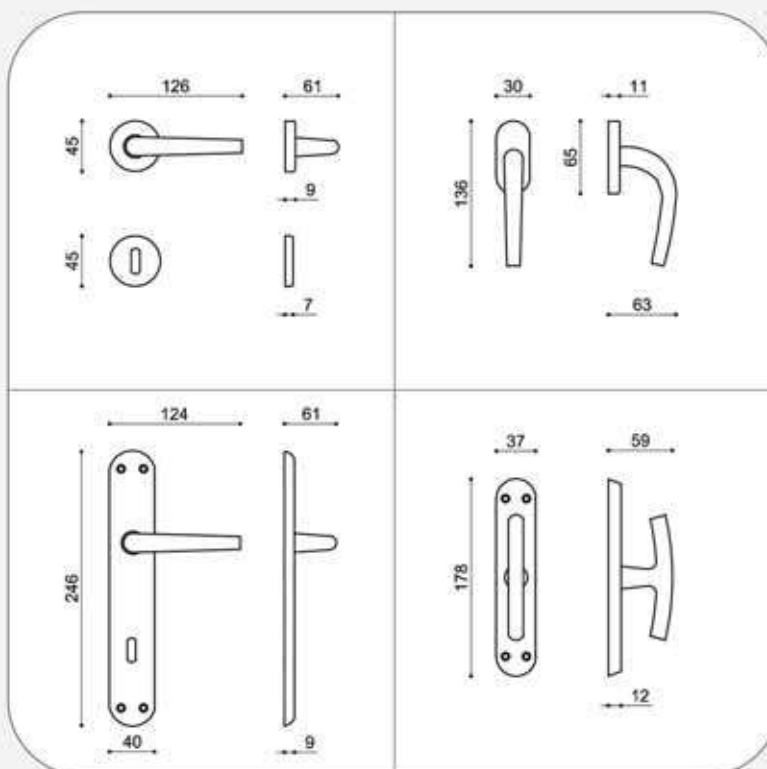

Rosetta standard:
R45 rosetta tonda d. 45 mm

Varianti:
R50 rosetta tonda d. 50 mm
RO rosetta ovale mm 30x60
nottolino Wc abbinato da pag. 320

Dry keep standard:
D dry keep ovale con mov. in metallo
7x42 mm con boccole art. 1672 pag. 364

Placca standard:
distanza 70/90/yale/Wc art. P101 pag. 358

Martellina standard:
placca art. P106 pag. 359 con quadro 7

Cremonese standard:
placca art. P106 pag. 359
movimento intercambiabile art. 1551 pag.365

finiture:
OLV ottone lucido verniciato
CS ottone cromato satinato
CR ottone cromato lucido
BG ottone bronzato graffiato

MORO maritech oro lucido
MCS maritech cromato satinato
MCR maritech cromato lucido
MBG maritech bronzato graffiato

370 Chiara

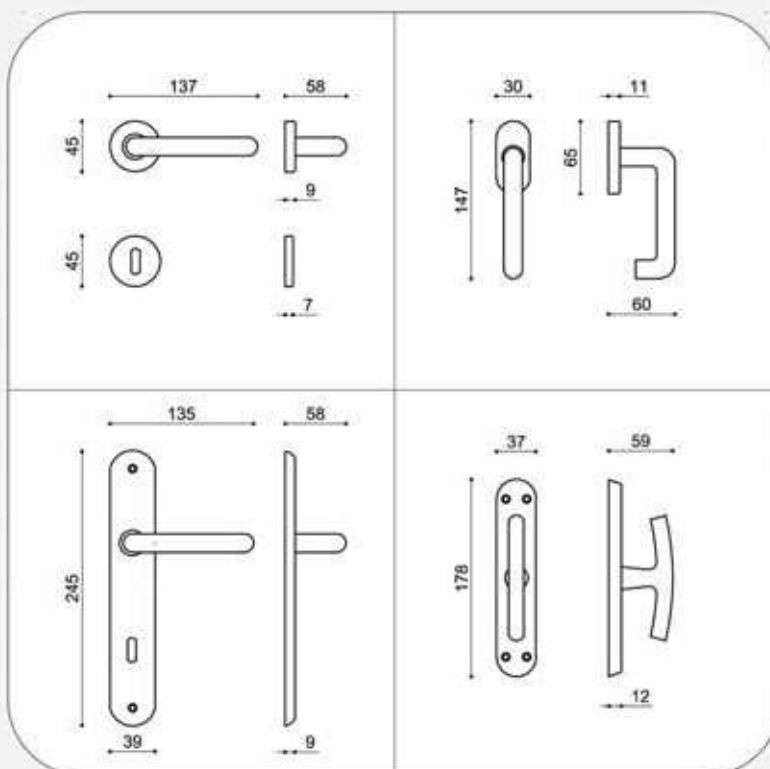

Rosetta standard:
R45 rosetta tonda d. 45 mm

Varianti:
R50 rosetta tonda d. 50 mm
RO rosetta ovale mm 30x60
nottolino Wc abbinato da pag. 320

Dry keep standard:
D dry keep ovale con mov. in metallo
7x42 mm con boccole art. 1672 pag. 364

Placca standard:
distanza 70/90/yale/Wc art. P102 pag. 358

Martellina standard:
placca art. P106 pag. 359 con quadro 7

Cremonese standard:
placca art. P106 pag. 359
movimento intercambiabile art. 1551 pag.365

finiture:
OLV ottone lucido verniciato
CS ottone cromato satinato
CR ottone cromato lucido

380 Cometa

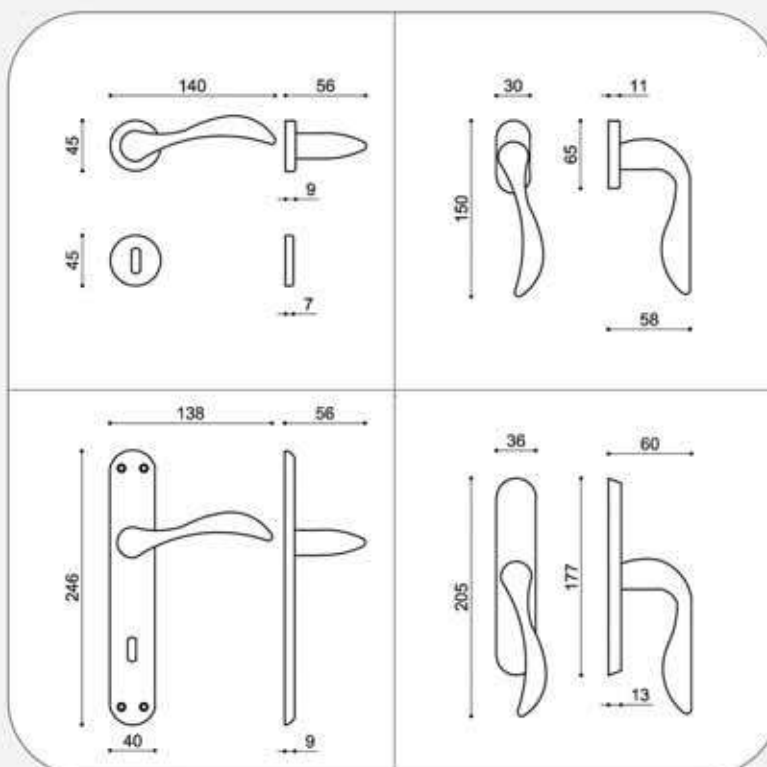

Rosetta standard:
R45 rosetta tonda d. 45 mm

Varianti:
R50 rosetta tonda d. 50 mm
RO rosetta ovale mm 30x60
nottolino Wc abbinato da pag. 320

Dry keep standard:
D dry keep ovale con mov. in metallo
7x42 mm con boccole art. 1672 pag. 364

Placca standard:
distanza 70/90/yale/Wc art. P101 pag. 358

Martellina standard:
placca art. P108 pag. 359 con movimento
rinforzato art. 1559 pag. 365

Cremonese standard:
placca art. P108 pag. 359
movimento intercambiabile art. 1551R pag.365

finiture:
OLV ottone lucido verniciato
CS ottone cromato satinato

450 Elisa

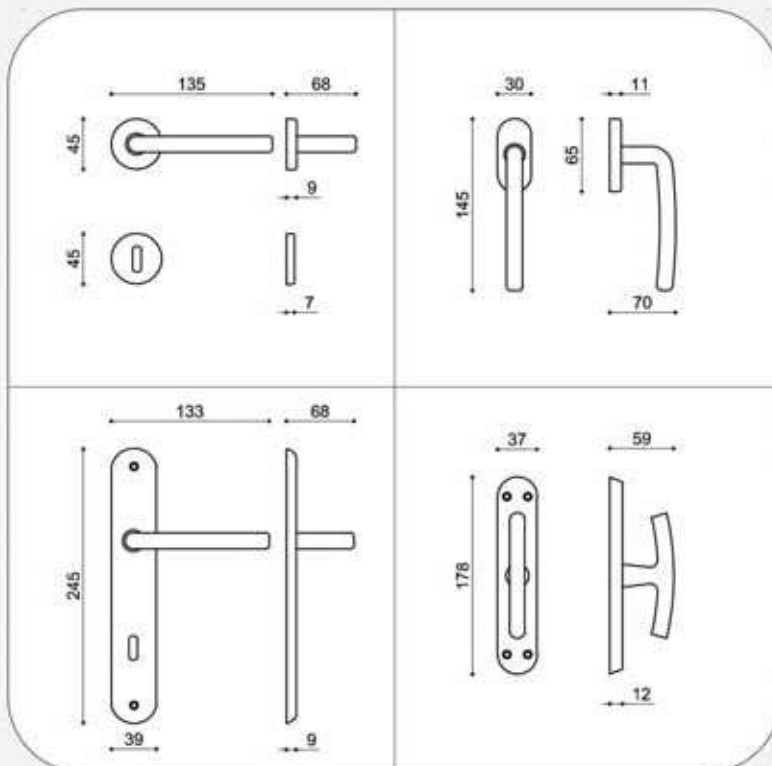

Rosetta standard:
R45 rosetta tonda d. 45 mm

Varianti:
R50 rosetta tonda d. 50 mm
RO rosetta ovale mm 30x60
nottolino Wc abbinato da pag. 320

Dry keep standard:
D dry keep ovale con mov. in metallo
7x42 mm con boccole art. 1672 pag. 364

Placca standard:
distanza 70/90/yale/Wc art. P102 pag. 358

Martellina standard:
placca art. P106 pag. 359 con quadro 7

Cremonese standard:
placca art. P106 pag. 359
movimento intercambiabile art. 1551 pag.365

finiture:
OLV ottone lucido verniciato
CS ottone cromato satinato
CR ottone cromato lucido
BG ottone bronzato graffiato

450B Elisa B

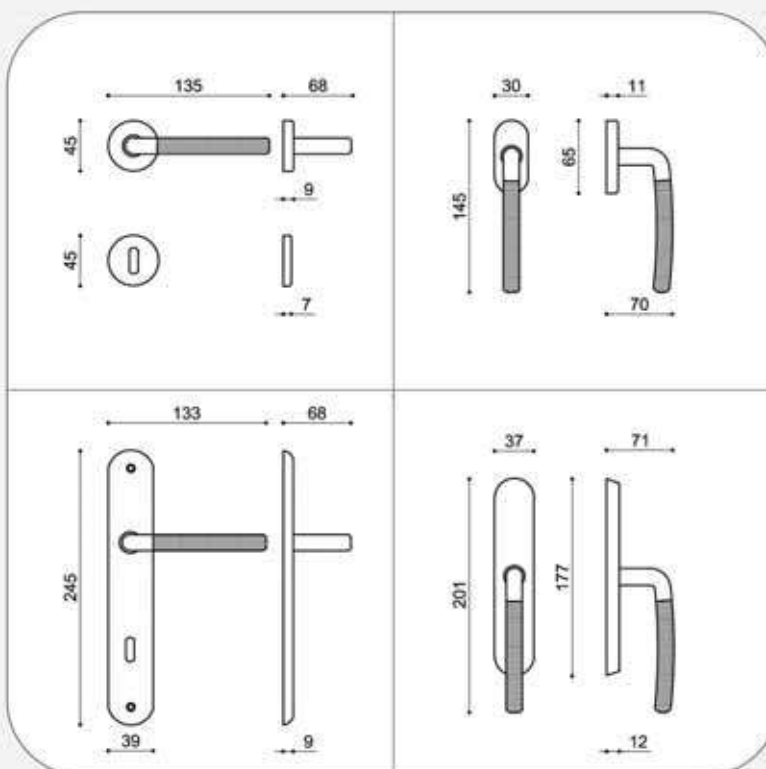

Rosetta standard:
R45 rosetta tonda d. 45 mm

Varianti:
R50 rosetta tonda d. 50 mm
RO rosetta ovale mm 30x60
nottolino Wc abbinato da pag. 320

Dry keep standard:
D dry keep ovale con mov. in metallo
7x42 mm con boccole art. 1672 pag. 364

Placca standard:
distanza 70/90/yale/Wc art. P102 pag. 358

Martellina standard:
placca art. P108 pag. 359 con movimento
rinforzato art. 1559 pag. 365

Cremonese standard:
placca art. P108 pag. 359
movimento intercambiabile art. 1551R pag.365

finiture:
OLV/OLS ottone bi colore lucido/satinato
CR/CS ottone bi colore cromo/satinato

580 Epoca

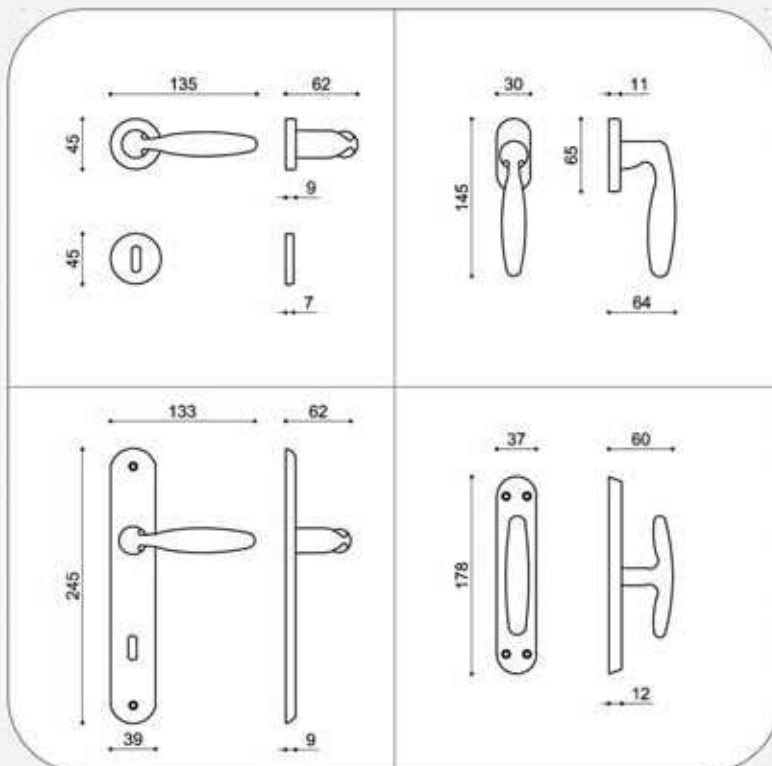

Rosetta standard:
R45 rosetta tonda d. 45 mm

Varianti:
R50 rosetta tonda d. 50 mm
RO rosetta ovale mm 30x60
nottolino Wc abbinato da pag. 320

Dry keep standard:
D dry keep ovale con mov. in metallo
7x42 mm con boccole art. 1672 pag. 364

Placca standard:
distanza 70/90/yale/Wc art. P102 pag. 358

Martellina standard:
placca art. P106 pag. 359 con quadro 7

Cremonese standard:
placca art. P106 pag. 359
movimento intercambiabile art. 1551 pag.365

finiture:
PVD ottone con trattamento PVD

OLV ottone lucido verniciato
SV ottone satinato verniciato
CS ottone cromato satinato
CR ottone cromato lucido
ANT ottone bronzo antico
ORO ottone oro antico
ARG ottone argento antico
BG ottone bronzato graffiato

580B Epoca B

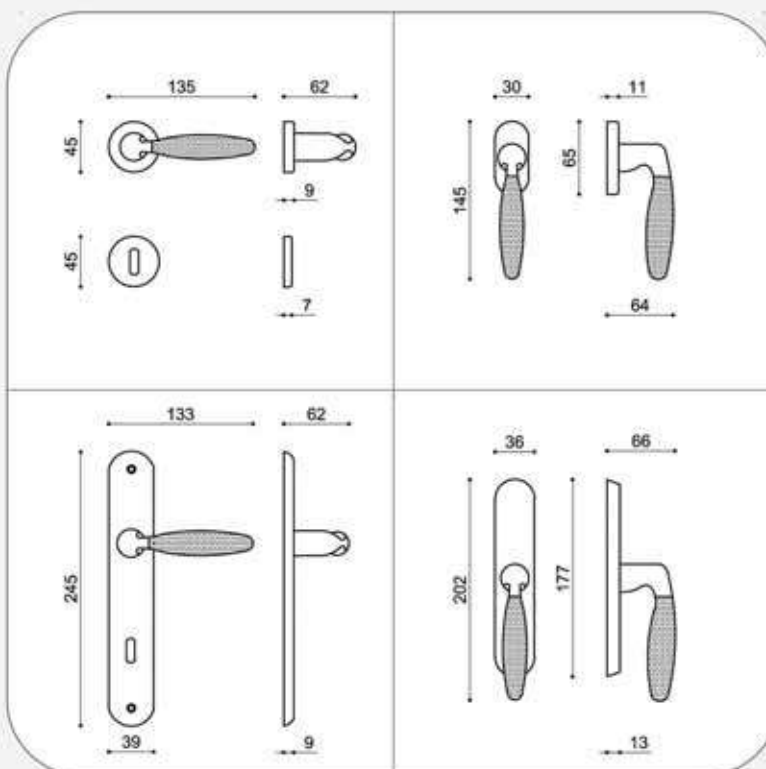

Rosetta standard:
R45 rosetta tonda d. 45 mm

Varianti:
R50 rosetta tonda d. 50 mm
RO rosetta ovale mm 30x60
nottolino Wc abbinato da pag. 320

Dry keep standard:
D dry keep ovale con mov. in metallo
7x42 mm con boccole art. 1672 pag. 364

Placca standard:
distanza 70/90/yale/Wc art. P102 pag. 358

Martellina standard:
placca art. P108 pag. 359 con movimento
rinforzato art. 1559 pag. 365

Cremonese standard:
placca art. P108 pag. 359
movimento intercambiabile art. 1551R pag.365

finiture:
PVD/SAT ottone bi colore con tratt. PVD/SAT

OLV/OLS ottone bi colore lucido/satinato
CR/CS ottone bi colore cromo/satinato

690 Opera

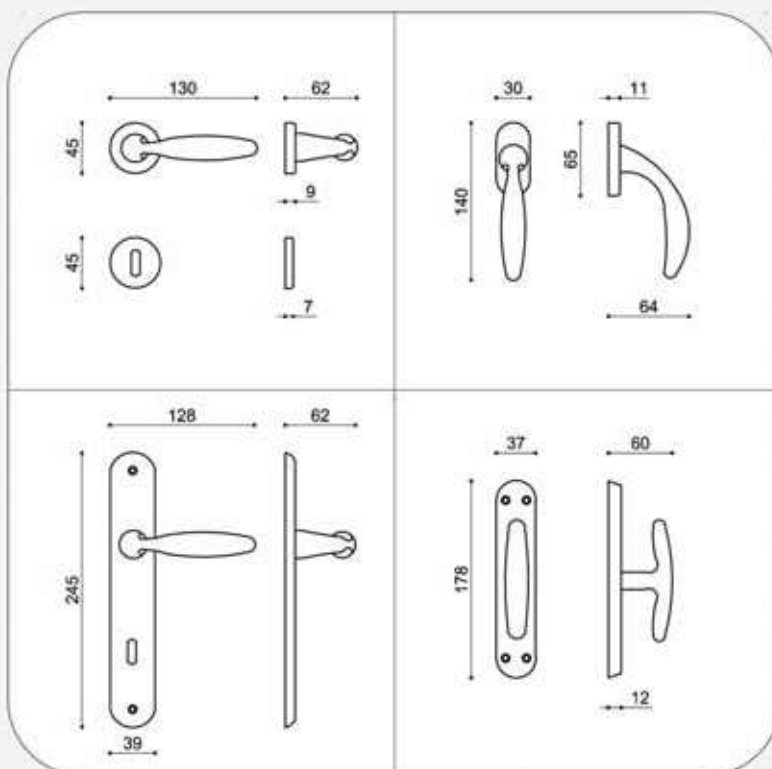

Rosetta standard:
R45 rosetta tonda d. 45 mm

Varianti:
R50 rosetta tonda d. 50 mm
RO rosetta ovale mm 30x60
nottolino Wc abbinato da pag. 320

Dry keep standard:
D dry keep ovale con mov. in metallo
7x42 mm con boccole art. 1672 pag. 364

Placca standard:
distanza 70/90/yale/Wc art. P102 pag. 358

Martellina standard:
placca art. P106 pag. 359 con quadro 7

Cremonese standard:
placca art. P106 pag. 359
movimento intercambiabile art. 1551 pag.365

finiture:
PVD ottone con trattamento PVD

OLV ottone lucido verniciato
SV ottone satinato verniciato
CS ottone cromato satinato
CR ottone cromato lucido
ANT ottone bronzo antico
ORO ottone oro antico
ARG ottone argento antico
BG ottone bronzato graffiato

691 Futura

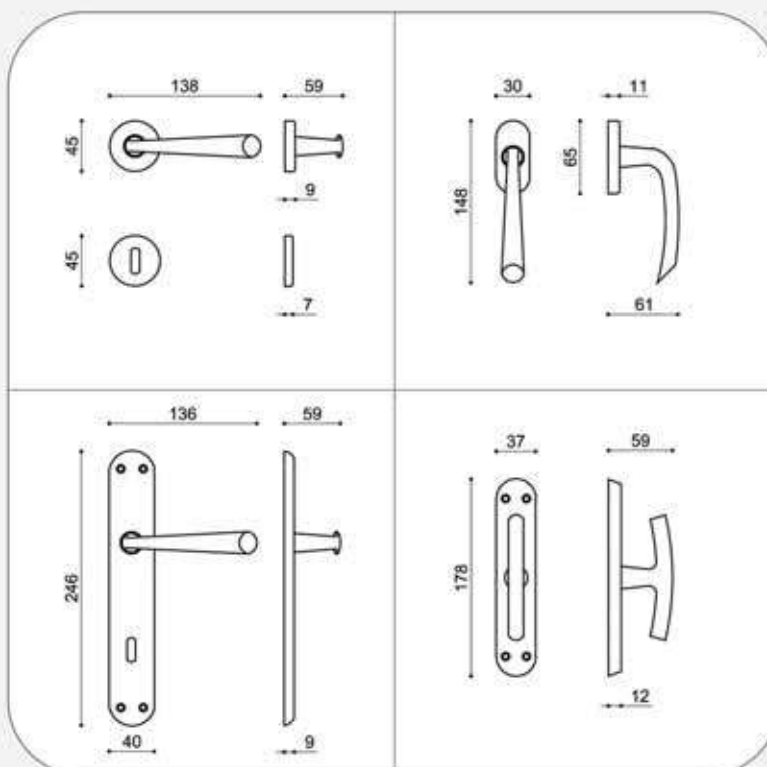

Rosetta standard:
R45 rosetta tonda d. 45 mm

Varianti:
R50 rosetta tonda d. 50 mm
RO rosetta ovale mm 30x60
nottolino Wc abbinato da pag. 320

Dry keep standard:
D dry keep ovale con mov. in metallo
7x42 mm con boccole art. 1672 pag. 364

Placca standard:
distanza 70/90/yale/Wc art. P101 pag. 358

Martellina standard:
placca art. P106 pag. 359 con quadro 7

Cremonese standard:
placca art. P106 pag. 359
movimento intercambiabile art. 1551 pag.365

finiture:
OLV ottone lucido verniciato
CS ottone cromato satinato

755 Antea

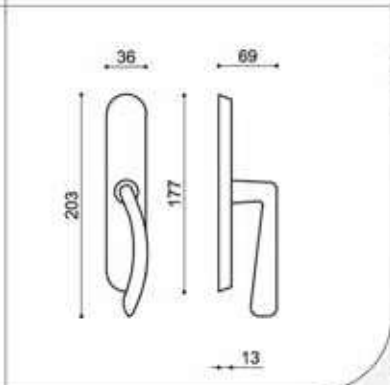
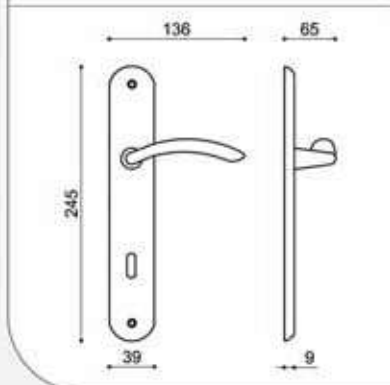
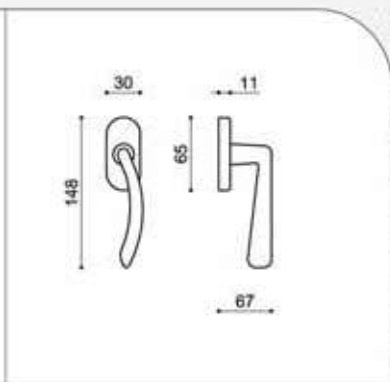
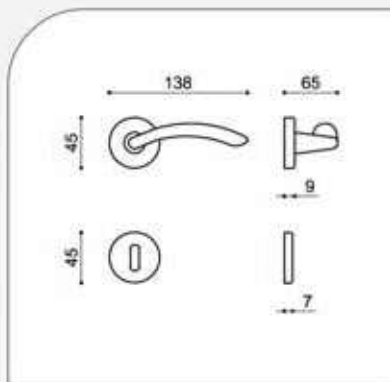

Rosetta standard:
R45 rosetta tonda d. 45 mm

Varianti:
R50 rosetta tonda d. 50 mm
RO rosetta ovale mm 30x60
nottolino Wc abbinato da pag. 320

Dry keep standard:
D dry keep ovale con mov. in metallo
7x42 mm con boccole art. 1672 pag. 364

Placca standard:
distanza 70/90/yale/Wc art. P102 pag. 358

Martellina standard:
placca art. P108 pag. 359 con movimento
rinforzato art. 1559 pag. 365

Cremonese standard:
placca art. P108 pag. 359
movimento intercambiabile art. 1551R pag.365

finiture:
OLV ottone lucido verniciato
CS ottone cromato satinato

755B Antea B

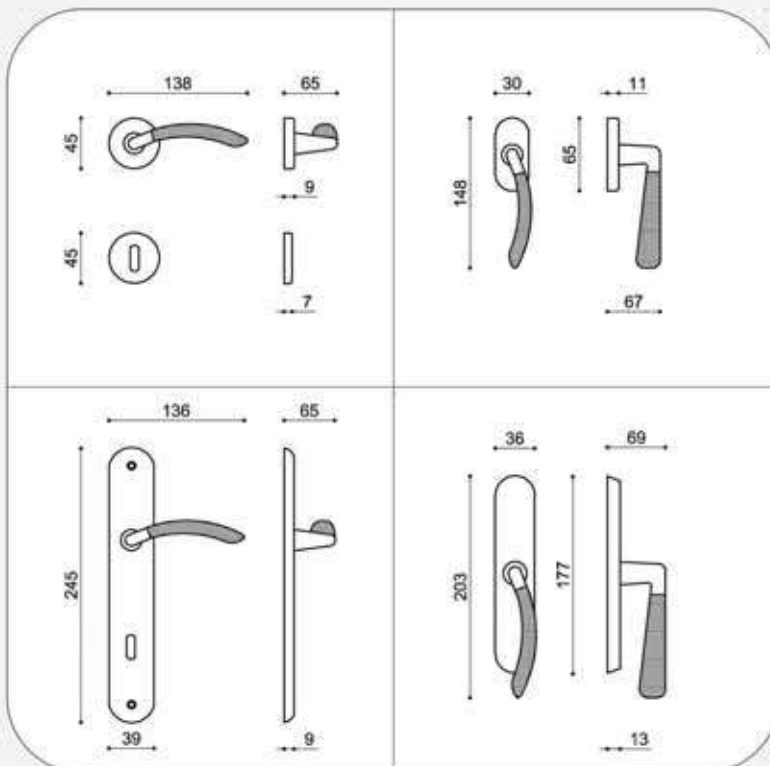

Rosetta standard:
R45 rosetta tonda d. 45 mm

Varianti:
R50 rosetta tonda d. 50 mm
RO rosetta ovale mm 30x60
nottolino Wc abbinato da pag. 320

Dry keep standard:
D dry keep ovale con mov. in metallo
7x42 mm con boccole art. 1672 pag. 364

Placca standard:
distanza 70/90/yale/Wc art. P102 pag. 358

Martellina standard:
placca art. P108 pag. 359 con movimento
rinforzato art. 1559 pag. 365

Cremonese standard:
placca art. P108 pag. 359
movimento intercambiabile art. 1551R pag.365

finiture:
OLV/OLS ottone bi colore lucido/satinato
CR/CS ottone bi colore cromo/satinato

765 Minerva

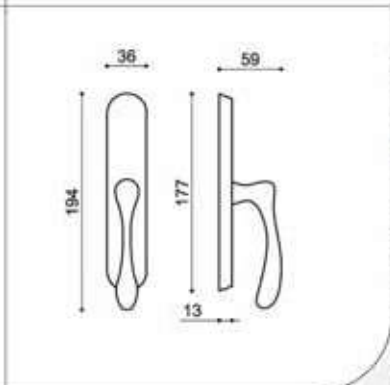
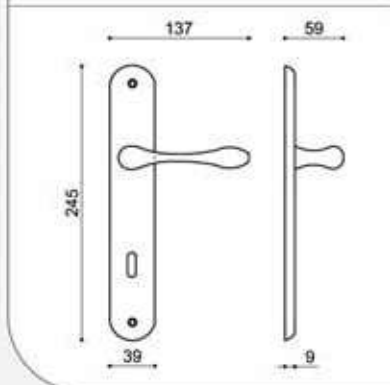
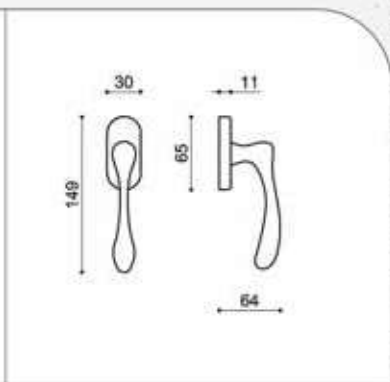
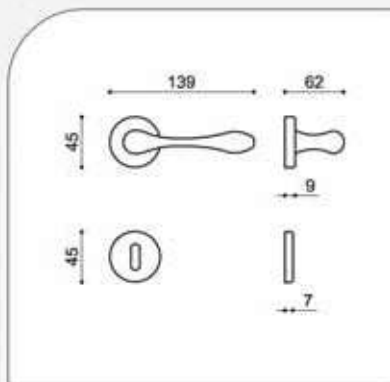

Rosetta standard:
R45 rosetta tonda d. 45 mm

Varianti:
R50 rosetta tonda d. 50 mm
RO rosetta ovale mm 30x60
nottolino Wc abbinato da pag. 320

Dry keep standard:
D dry keep ovale con mov. in metallo
7x42 mm con boccole art. 1672 pag. 364

Placca standard:
distanza 70/90/yale/Wc art. P102 pag. 358

Martellina standard:
placca art. P108 pag. 359 con movimento rinforzato art. 1559 pag. 365

Cremonese standard:
placca art. P108 pag. 359
movimento intercambiabile art. 1551R pag.365

finiture:
PVD ottone con trattamento PVD

OLV ottone lucido verniciato
SV ottone satinato verniciato
CS ottone cromato satinato
CR ottone cromato lucido
ANT ottone bronzo antico
ORO ottone oro antico
ARG ottone argento antico
RAM ottone ramato antico
BG ottone bronzato graffiato

765B Minerva B

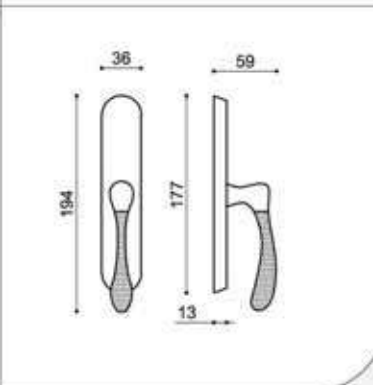
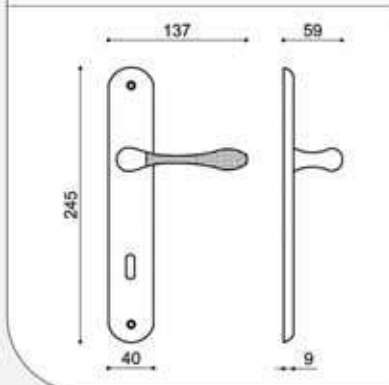
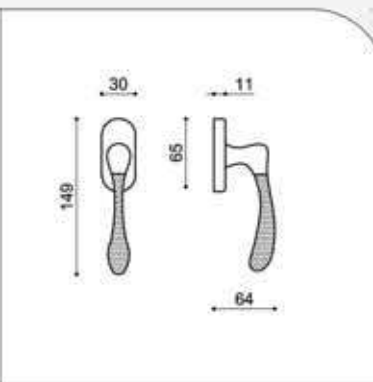
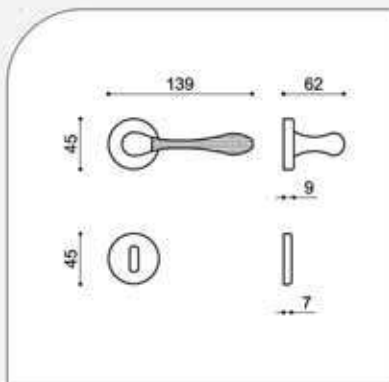

Rosetta standard:
R45 rosetta tonda d. 45 mm

Varianti:
R50 rosetta tonda d. 50 mm
RO rosetta ovale mm 30x60
nottolino Wc abbinato da pag. 320

Dry keep standard:
D dry keep ovale con mov. in metallo
7x42 mm con boccole art. 1672 pag. 364

Placca standard:
distanza 70/90/yale/Wc art. P102 pag. 358

Martellina standard:
placca art. P108 pag. 359 con movimento
rinforzato art. 1559 pag. 365

Cremonese standard:
placca art. P108 pag. 359
movimento intercambiabile art. 1551R pag.365

finiture:
PVD/SAT ottone bi colore con tratt. PVD/SAT

OLV/OLS ottone bi colore lucido/satinato
CR/CS ottone bi colore cromo/satinato

769 Cuba



versione con rosetta tonda

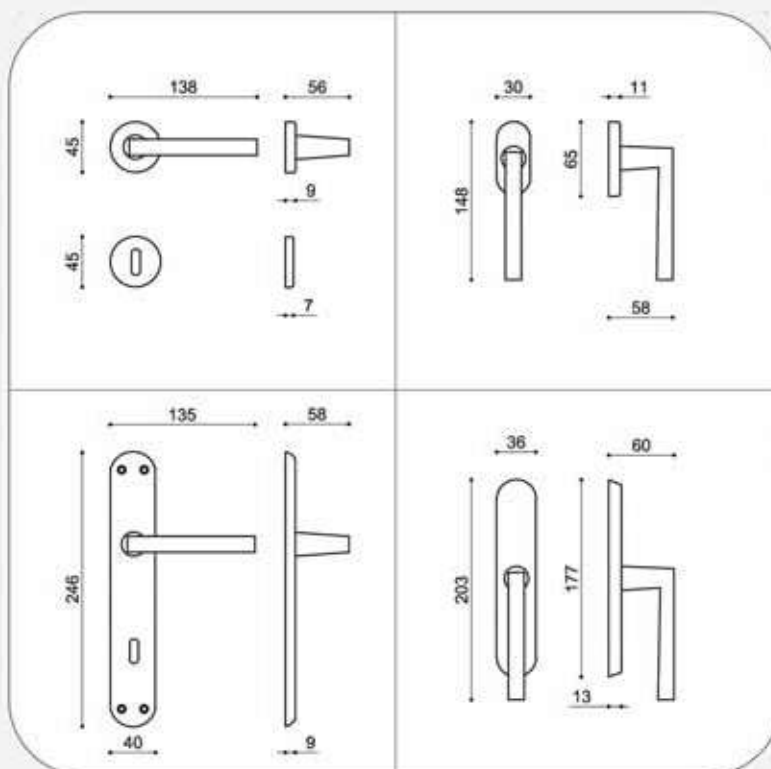

Rosetta standard:
R45 rosetta tonda d. 45 mm

Varianti:
R50 rosetta tonda d. 50 mm
RO rosetta ovale mm 30x60
nottolino Wc abbinato da pag. 320

Dry keep standard:
D dry keep ovale con mov. in metallo
7x42 mm con boccole art. 1672 pag. 364

Placca standard:
distanza 70/90/yale/Wc art. P101 pag. 358

Martellina standard:
placca art. P108 pag. 359 con movimento
rinforzato art. 1559 pag. 365

Cremonese standard:
placca art. P108 pag. 359
movimento intercambiabile art. 1551R pag.365

finiture:
MCS maritech cromato satinato
MCR maritech cromato lucido

769B Cuba B



versione con rosetta tonda

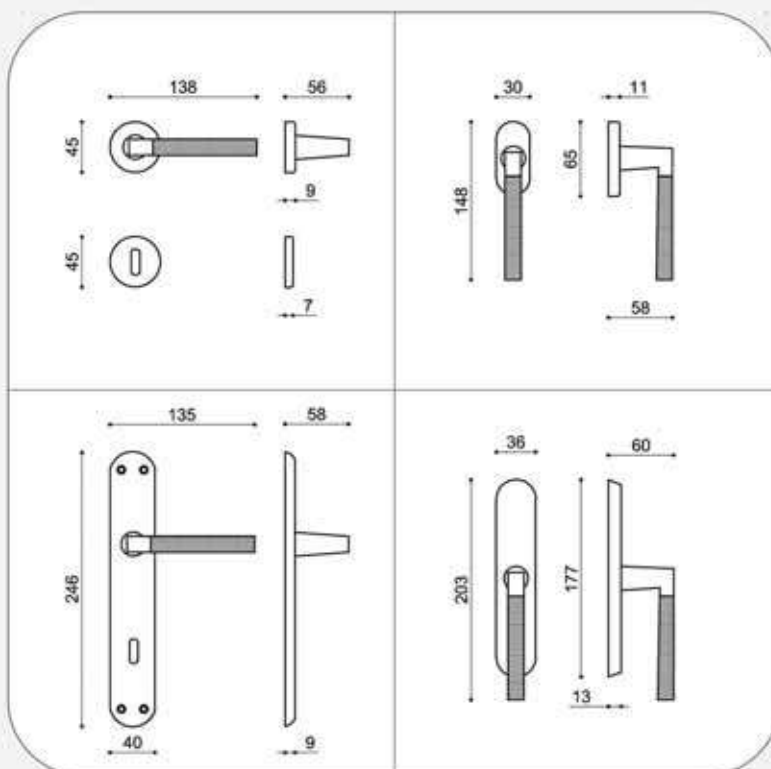

Rosetta standard:
R45 rosetta tonda d. 45 mm

Varianti:
R50 rosetta tonda d. 50 mm
RO rosetta ovale mm 30x60
nottolino Wc abbinato da pag. 320

Dry keep standard:
D dry keep ovale con mov. in metallo
7x42 mm con boccole art. 1672 pag. 364

Placca standard:
distanza 70/90/yale/Wc art. P101 pag. 358

Martellina standard:
placca art. P108 pag. 359 con movimento
rinforzato art. 1559 pag. 365

Cremonese standard:
placca art. P108 pag. 359
movimento intercambiabile art. 1551R pag.365

finiture:
MCR/CS maritech bi colore cromo/satinato

1050 Onda

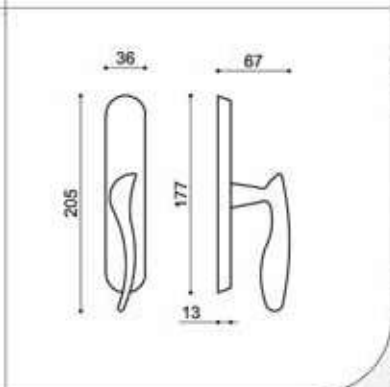
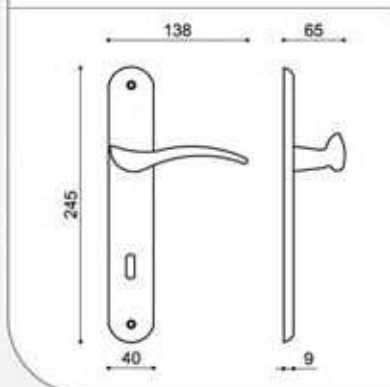
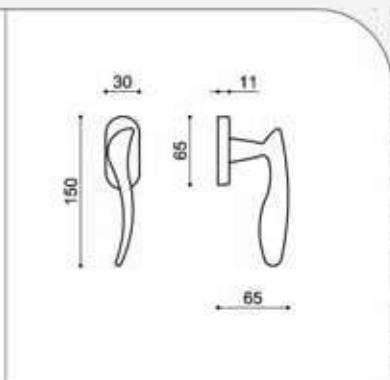
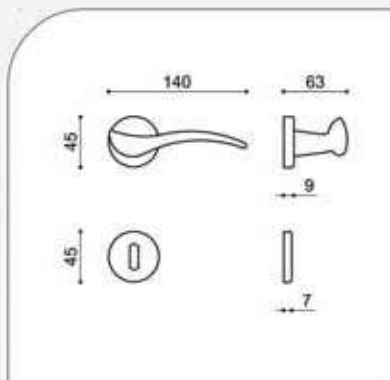

Rosetta standard:
R45 rosetta tonda d. 45 mm

Varianti:
R50 rosetta tonda d. 50 mm
RO rosetta ovale mm 30x60
nottolino Wc abbinato da pag. 320

Dry keep standard:
D dry keep ovale con mov. in metallo
7x42 mm con boccole art. 1672 pag. 364

Placca standard:
distanza 70/90/yale/Wc art. P102 pag. 358

Martellina standard:
placca art. P108 pag. 359 con movimento
rinforzato art. 1559 pag. 365

Cremonese standard:
placca art. P108 pag. 359
movimento intercambiabile art. 1551R pag.365

finiture:
OLV ottone lucido verniciato
SV ottone satinato verniciato
CS ottone cromato satinato
CR ottone cromato lucido
BG ottone bronzato graffiato

1055 Ines

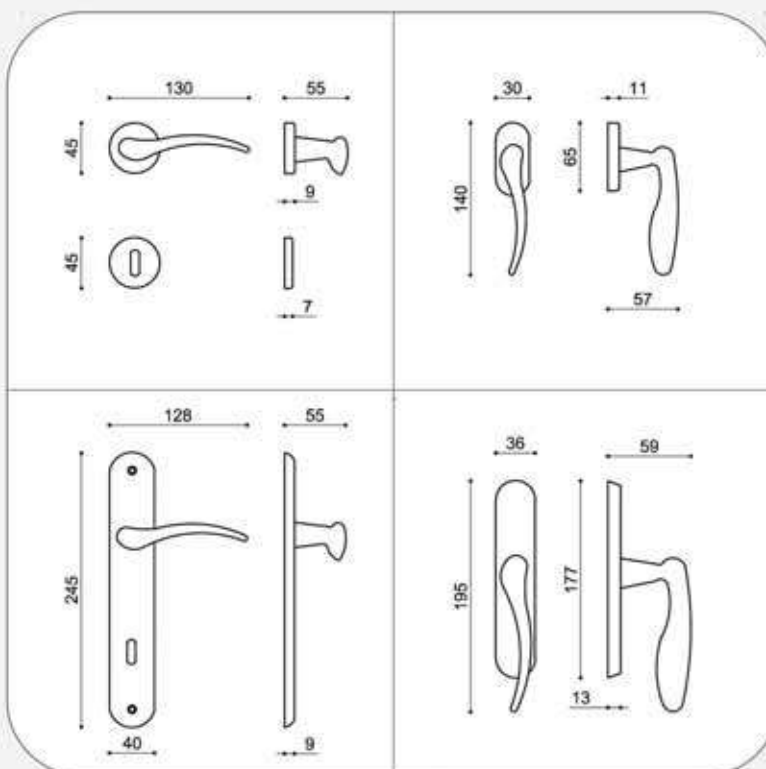

Rosetta standard:
R45 rosetta tonda d. 45 mm

Varianti:
R50 rosetta tonda d. 50 mm
RO rosetta ovale mm 30x60
nottolino Wc abbinato da pag. 320

Dry keep standard:
D dry keep ovale con mov. in metallo
7x42 mm con boccole art. 1672 pag. 364

Placca standard:
distanza 70/90/yale/Wc art. P102 pag. 358

Martellina standard:
placca art. P108 pag. 359 con movimento
rinforzato art. 1559 pag. 365

Cremonese standard:
placca art. P108 pag. 359
movimento intercambiabile art. 1551R pag.365

finiture:
MORO maritech oro lucido
MCS maritech cromato satinato
MCR maritech cromato lucido
MBG maritech bronzo graffiato

1060 Alfa

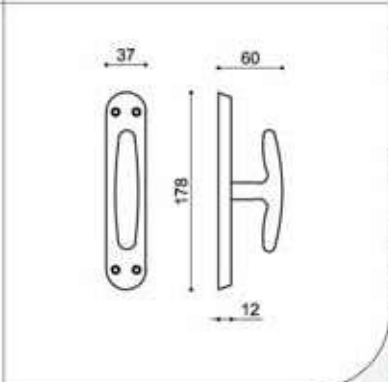
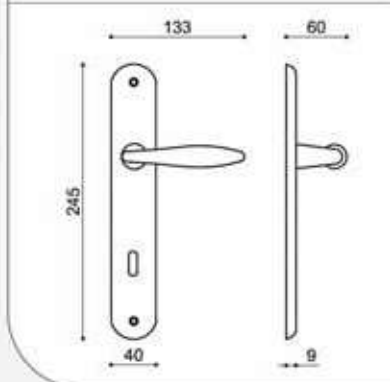
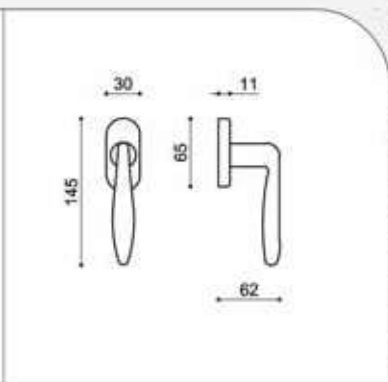
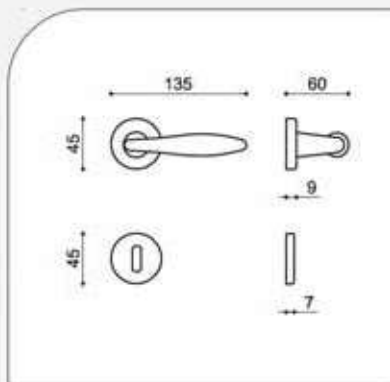

Rosetta standard:
R45 rosetta tonda d. 45 mm

Varianti:
R50 rosetta tonda d. 50 mm
RO rosetta ovale mm 30x60
nottolino Wc abbinato da pag. 320

Dry keep standard:
D dry keep ovale con mov. in metallo
7x42 mm con boccole art. 1672 pag. 364

Placca standard:
distanza 70/90/yale/Wc art. P102 pag. 358

Martellina standard:
placca art. P106 pag. 359 con quadro 7

Cremonese standard:
placca art. P106 pag. 359
movimento intercambiabile art. 1551 pag.365

finiture:
PVD ottone con trattamento PVD

OLV ottone lucido verniciato
SV ottone satinato verniciato
CS ottone cromato satinato
CR ottone cromato lucido
BG ottone bronzato graffiato

MORO maritech oro lucido
MCS maritech cromato satinato

1060B Alfa B

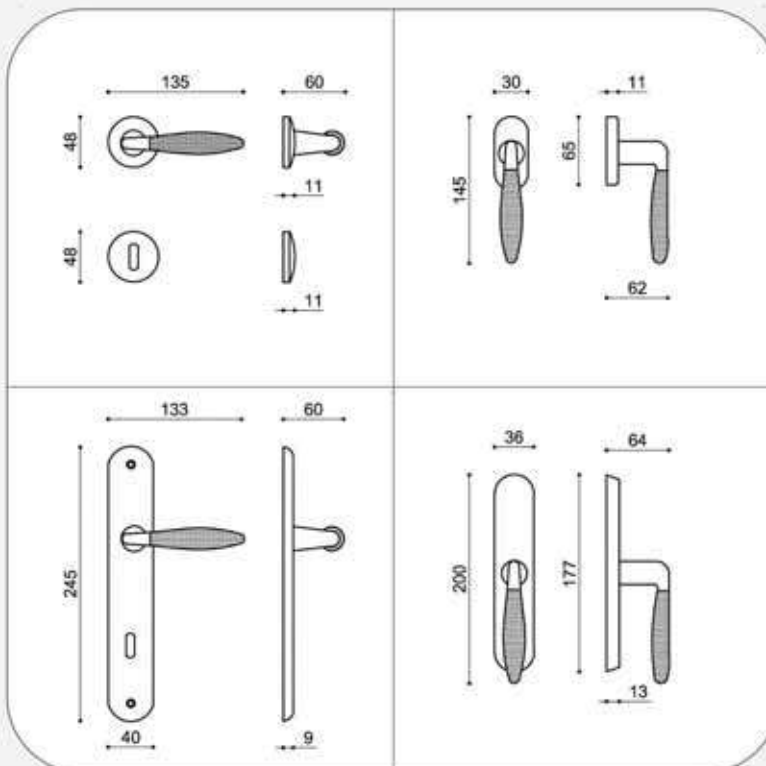

Rosetta standard:
R45 rosetta tonda d. 45 mm

Varianti:
R50 rosetta tonda d. 50 mm
RO rosetta ovale mm 30x60
nottolino Wc abbinato da pag. 320

Dry keep standard:
D dry keep ovale con mov. in metallo
7x42 mm con boccole art. 1672 pag. 364

Placca standard:
distanza 70/90/yale/Wc art. P102 pag. 358

Martellina standard:
placca art. P108 pag. 359 con movimento
rinforzato art. 1559 pag. 365

Cremonese standard:
placca art. P108 pag. 359
movimento intercambiabile art. 1551R pag.365

finiture:
PVD/SAT ottone bi colore con tratt. PVD/SAT

OLV/OLS ottone bi colore lucido/satinato
CR/CS ottone bi colore cromo/satinato

MCR/CS maritech bi colore cromo/satinato

1062B Luna B

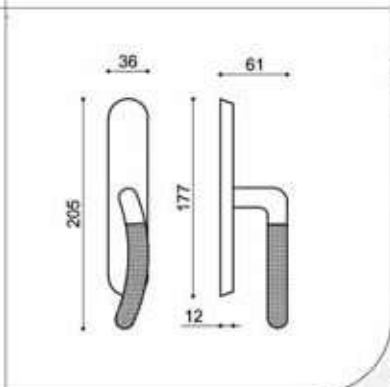
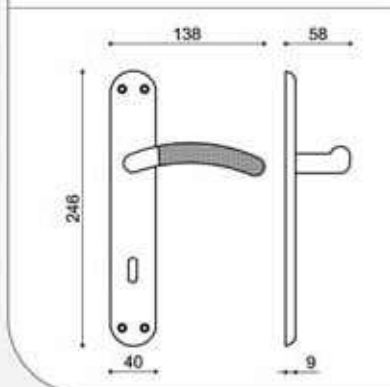
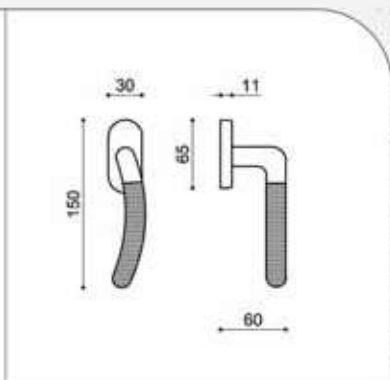
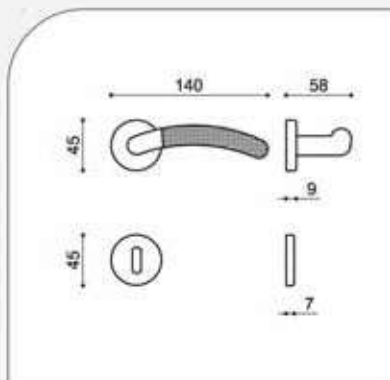

Rosetta standard:
R45 rosetta tonda d. 45 mm

Varianti:
R50 rosetta tonda d. 50 mm
RO rosetta ovale mm 30x60
nottolino Wc abbinato da pag. 320

Dry keep standard:
D dry keep ovale con mov. in metallo
7x42 mm con boccole art. 1672 pag. 364

Placca standard:
distanza 70/90/yale/Wc art. P101 pag. 358

Martellina standard:
placca art. P108 pag. 359 con movimento
rinforzato art. 1559 pag. 365

Cremonese standard:
placca art. P108 pag. 359
movimento intercambiabile art. 1551R pag.365

finiture:
OLV/OLS ottone bi colore lucido/satinato
CR/CS ottone bi colore cromo/satinato

1110 Giada

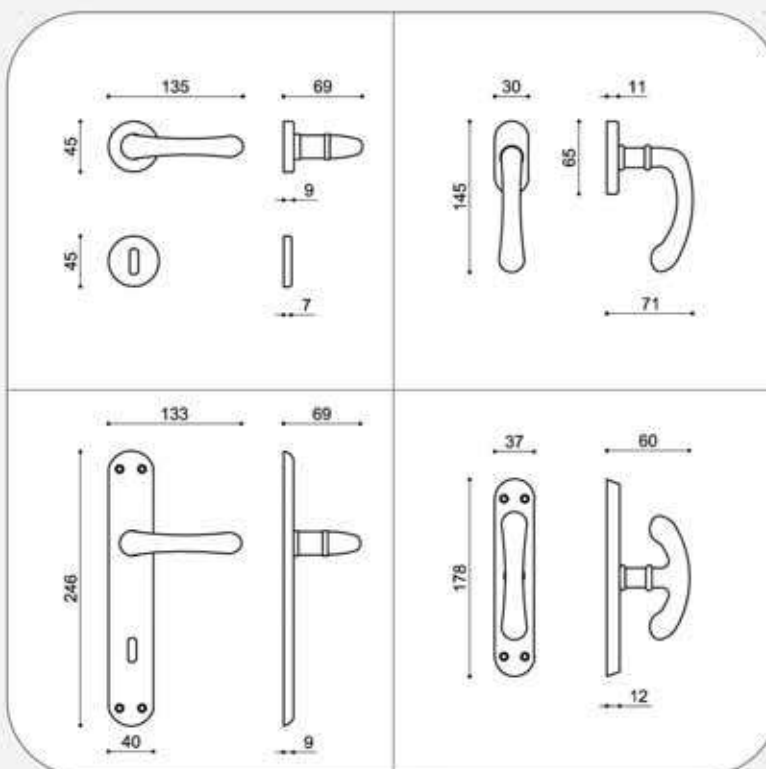
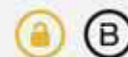

Rosetta standard:
R45 rosetta tonda d. 45 mm

Varianti:
R50 rosetta tonda d. 50 mm
RO rosetta ovale mm 30x60
nottolino Wc abbinato da pag. 320

Dry keep standard:
D dry keep ovale con mov. in metallo
7x42 mm con boccole art. 1672 pag. 364

Placca standard:
distanza 70/90/yale/Wc art. P101 pag. 358

Martellina standard:
placca art. P106 pag. 359 con quadro 7

Cremonese standard:
placca art. P106 pag. 359
movimento intercambiabile art. 1551 pag.365

finiture:
OLV ottone lucido verniciato
CS ottone cromato satinato
BG ottone bronzato graffiato

1125 Rugiada

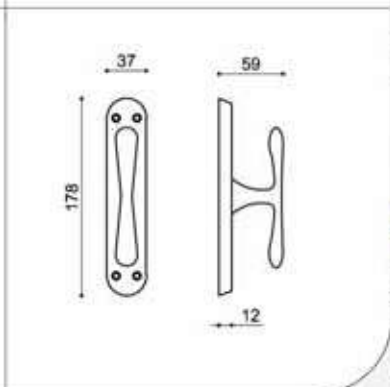
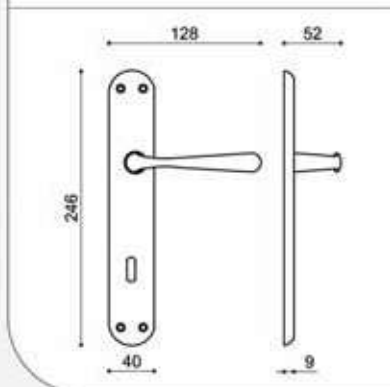
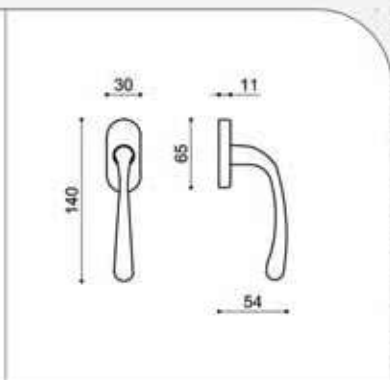
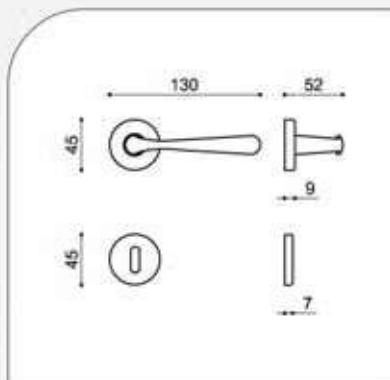

Rosetta standard:
R45 rosetta tonda d. 45 mm

Varianti:
R50 rosetta tonda d. 50 mm
RO rosetta ovale mm 30x60
nottolino Wc abbinato da pag. 320

Dry keep standard:
D dry keep ovale con mov. in metallo
7x42 mm con boccole art. 1672 pag. 364

Placca standard:
distanza 70/90/yale/Wc art. P101 pag. 358

Martellina standard:
placca art. P106 pag. 359 con quadro 7

Cremonese standard:
placca art. P106 pag. 359
movimento intercambiabile art. 1551 pag.365

finiture:
PVD ottone con trattamento PVD

OLV ottone lucido verniciato
SV ottone satinato verniciato
CS ottone cromato satinato
CR ottone cromato lucido
ANT ottone bronzo antico
BG ottone bronzato graffiato

1126 Sidney

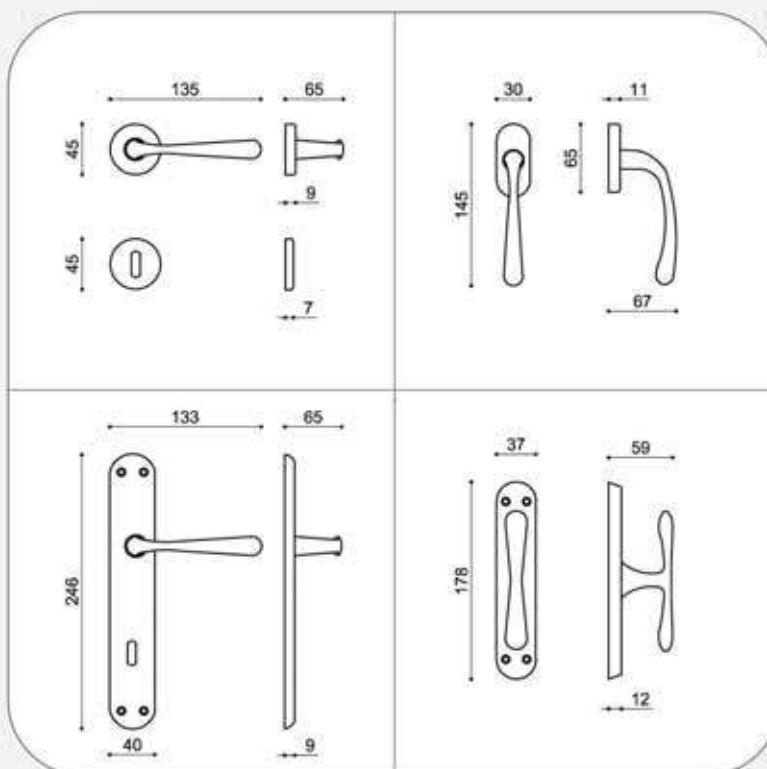

Rosetta standard:
R45 rosetta tonda d. 45 mm

Varianti:
R50 rosetta tonda d. 50 mm
RO rosetta ovale mm 30x60
nottolino Wc abbinato da pag. 320

Dry keep standard:
D dry keep ovale con mov. in metallo
7x42 mm con boccole art. 1672 pag. 364

Placca standard:
distanza 70/90/yale/Wc art. P101 pag. 358

Martellina standard:
placca art. P106 pag. 359 con quadro 7

Cremonese standard:
placca art. P106 pag. 359
movimento intercambiabile art. 1551 pag.365

finiture:
OLV ottone lucido verniciato
CS ottone cromato satinato
CR ottone cromato lucido
ANT ottone bronzo antico
BG ottone bronzato graffiato

MORO maritech oro lucido
MCS maritech cromato satinato
MCR maritech cromato lucido
MBG maritech bronzato graffiato

1127 Nuvola

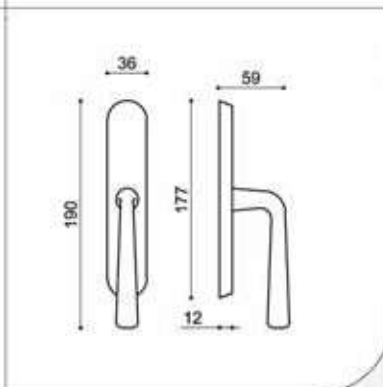
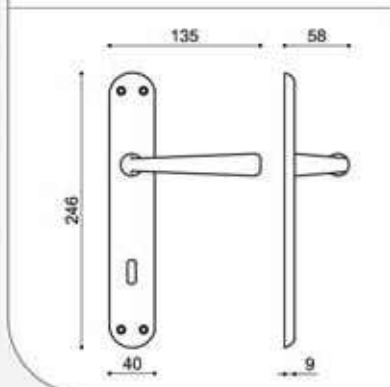
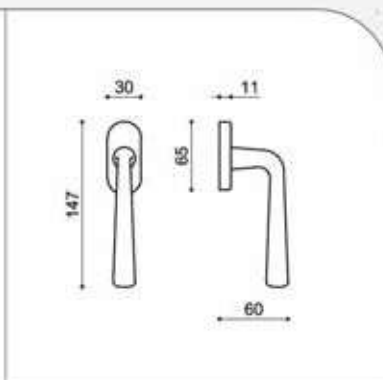
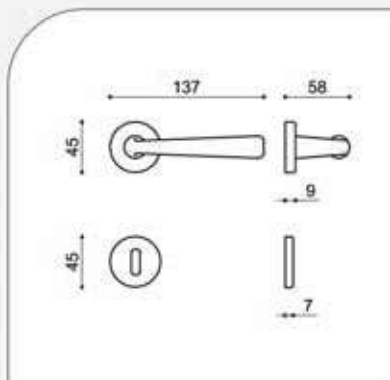

Rosetta standard:
R45 rosetta tonda d. 45 mm

Varianti:
R50 rosetta tonda d. 50 mm
RO rosetta ovale mm 30x60
nottolino Wc abbinato da pag. 320

Dry keep standard:
D dry keep ovale con mov. in metallo
7x42 mm con boccole art. 1672 pag. 364

Placca standard:
distanza 70/90/yale/Wc art. P101 pag. 358

Martellina standard:
placca art. P108 pag. 359 con movimento
rinforzato art. 1559 pag. 365

Cremonese standard:
placca art. P108 pag. 359
movimento intercambiabile art. 1551R pag.365

finiture:
MORO maritech oro lucido
MCS maritech cromato satinato
MCR maritech cromato lucido

1127B Nuvola B

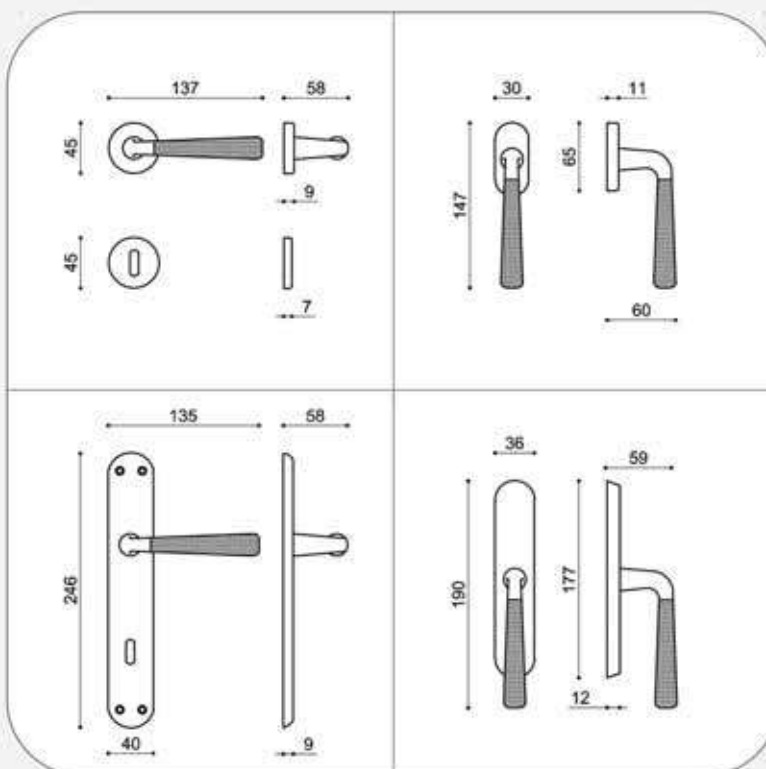

Rosetta standard:
R45 rosetta tonda d. 45 mm

Varianti:
R50 rosetta tonda d. 50 mm
RO rosetta ovale mm 30x60
nottolino Wc abbinato da pag. 320

Dry keep standard:
D dry keep ovale con mov. in metallo
7x42 mm con boccole art. 1672 pag. 364

Placca standard:
distanza 70/90/yale/Wc art. P101 pag. 358

Martellina standard:
placca art. P108 pag. 359 con movimento
rinforzato art. 1559 pag. 365

Cremonese standard:
placca art. P108 pag. 359
movimento intercambiabile art. 1551R pag.365

finiture:
MORO/SAT maritehc bi colore oro/satinato
MCR/CS maritech bi colore cromo/satinato

1128 Asia

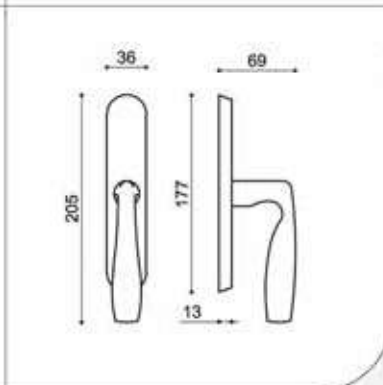
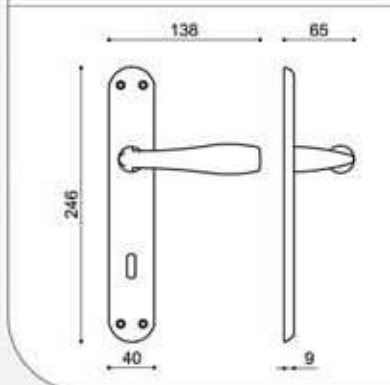
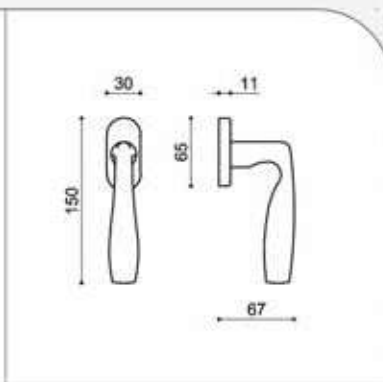
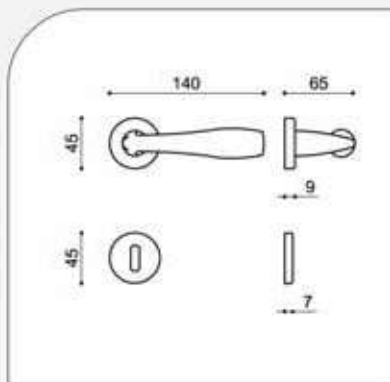

Rosetta standard:
R45 rosetta tonda d. 45 mm

Varianti:
R50 rosetta tonda d. 50 mm
RO rosetta ovale mm 30x60
nottolino Wc abbinato da pag. 320

Dry keep standard:
D dry keep ovale con mov. in metallo
7x42 mm con boccole art. 1672 pag. 364

Placca standard:
distanza 70/90/yale/Wc art. P101 pag. 358

Martellina standard:
placca art. P108 pag. 359 con movimento
rinforzato art. 1559 pag. 365

Cremonese standard:
placca art. P108 pag. 359
movimento intercambiabile art. 1551R pag.365

finiture:
MORO maritech oro lucido
MCS maritech cromato satinato

1129 Arianna

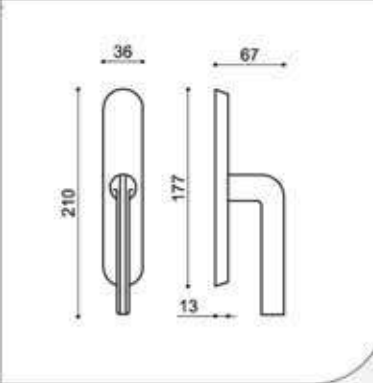
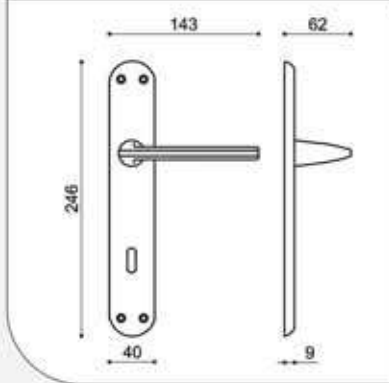
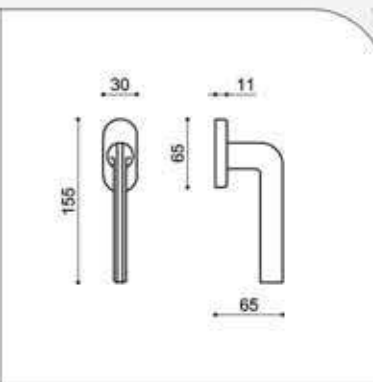
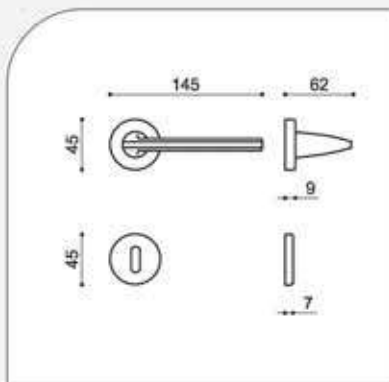

Rosetta standard:
R45 rosetta tonda d. 45 mm

Varianti:
R50 rosetta tonda d. 50 mm
RO rosetta ovale mm 30x60
nottolino Wc abbinato da pag. 320

Dry keep standard:
D dry keep ovale con mov. in metallo
7x42 mm con boccole art. 1672 pag. 364

Placca standard:
distanza 70/90/yale/Wc art. P101 pag. 358

Martellina standard:
placca art. P108 pag. 359 con movimento
rinforzato art. 1559 pag. 365

Cremonese standard:
placca art. P108 pag. 359
movimento intercambiabile art. 1551R pag.365

finiture:
MORO maritech oro lucido
MCS maritech cromato satinato
MCR maritech cromato lucido

1260 Uovo

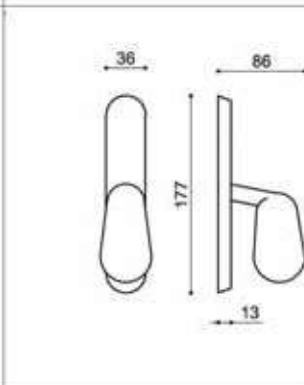
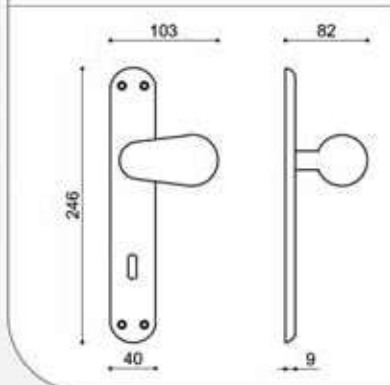
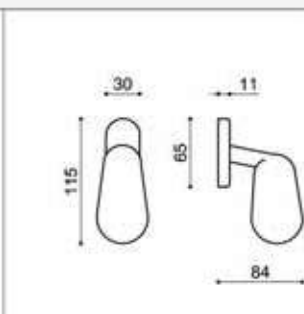
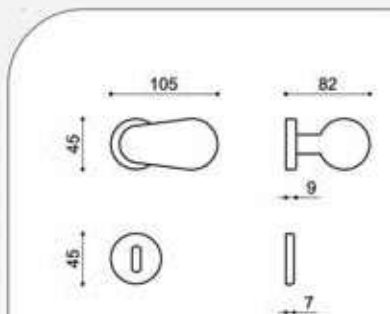

Rosetta standard:
R45 rosetta tonda d. 45 mm

Varianti:
R50 rosetta tonda d. 50 mm
RO rosetta ovale mm 30x60
nottolino Wc abbinato da pag. 320

Dry keep standard:
D dry keep ovale con mov. in metallo
7x42 mm con boccole art. 1672 pag. 364

Placca standard:
distanza 70/90/yale/Wc art. P101 pag. 358

Martellina standard:
placca art. P108 pag. 359 con movimento rinforzato art. 1559 pag. 365

Cremonese standard:
placca art. P108 pag. 359
movimento intercambiabile art. 1551R pag.365

finiture:
PVD ottone con trattamento PVD

OLV ottone lucido verniciato
SV ottone satinato verniciato
CS ottone cromato satinato
CR ottone cromato lucido
ANT ottone bronzo antico
BG ottone bronzato graffiato

1775 Aurelia

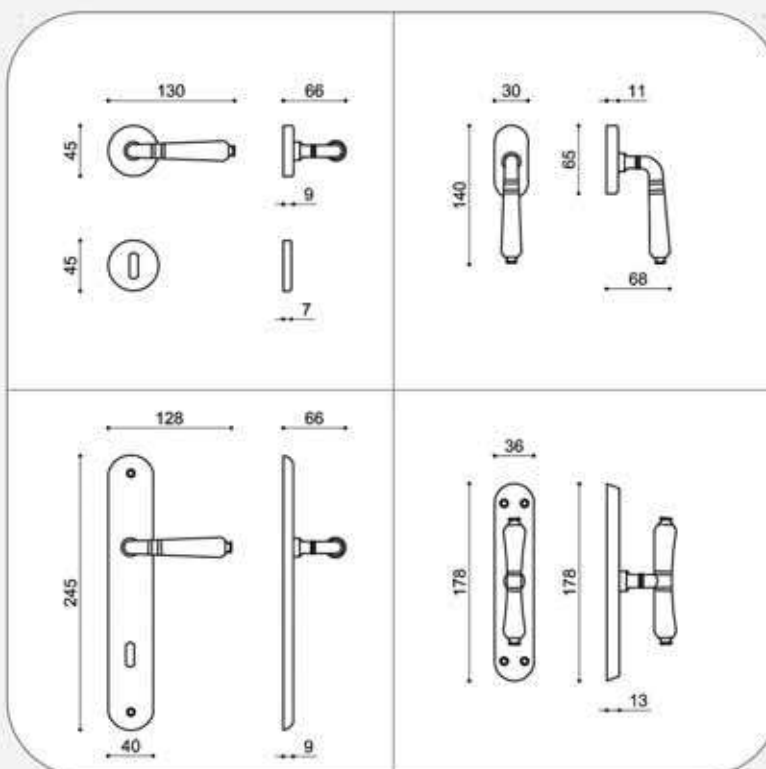

Rosetta standard:
R45 rosetta tonda d. 45 mm

Varianti:
R50 rosetta tonda d. 50 mm
RO rosetta ovale mm 30x60
nottolino Wc abbinato da pag. 320

Dry keep standard:
D dry keep ovale con mov. in metallo
7x42 mm con boccole art. 1672 pag. 364

Placca standard:
distanza 70/90/yale/Wc art. P102 pag. 358

Martellina standard:
placca art. P106 pag. 359 con quadro 7

Cremonese standard:
placca art. P106 pag. 359
movimento intercambiabile art. 1551 pag.365

finiture:
OLV ottone lucido verniciato
CR ottone cromato lucido
ANT ottone bronzo antico
ORO ottone oro antico
ARG ottone argento antico
RAM ottone ramato antico

1778 Torino

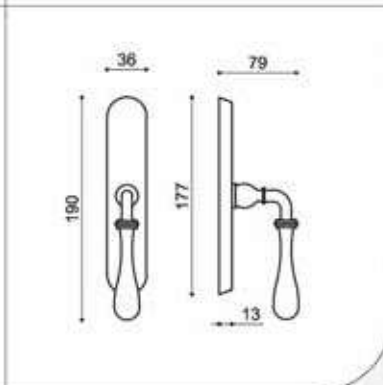
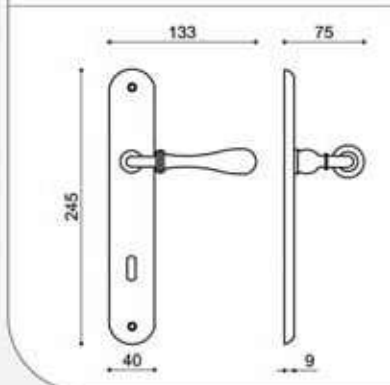
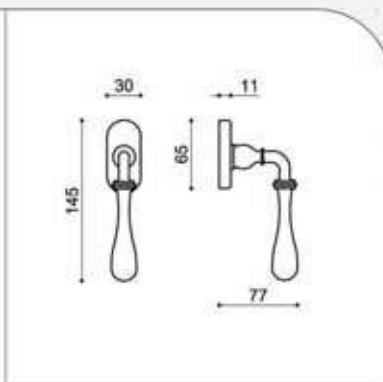
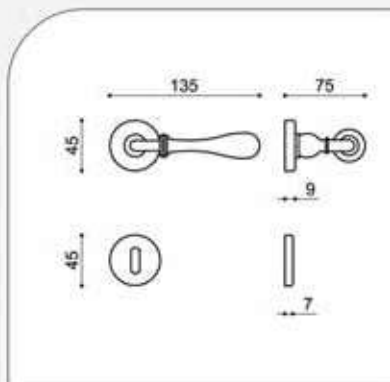
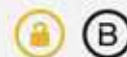

Rosetta standard:
R45 rosetta tonda d. 45 mm

Varianti:
R50 rosetta tonda d. 50 mm
RO rosetta ovale mm 30x60
nottolino Wc abbinato da pag. 320

Dry keep standard:
D dry keep ovale con mov. in metallo
7x42 mm con boccole art. 1672 pag. 364

Placca standard:
distanza 70/90/yale/Wc art. P102 pag. 358

Martellina standard:
placca art. P108 pag. 359 con movimento
rinforzato art. 1559 pag. 365

Cremonese standard:
placca art. P108 pag. 359
movimento intercambiabile art. 1551R pag.365

finiture:
OLV ottone lucido verniciato
ANT ottone bronzo antico
ORO ottone oro antico
ARG ottone argento antico
RAM ottone ramato antico

1779 Viareggio

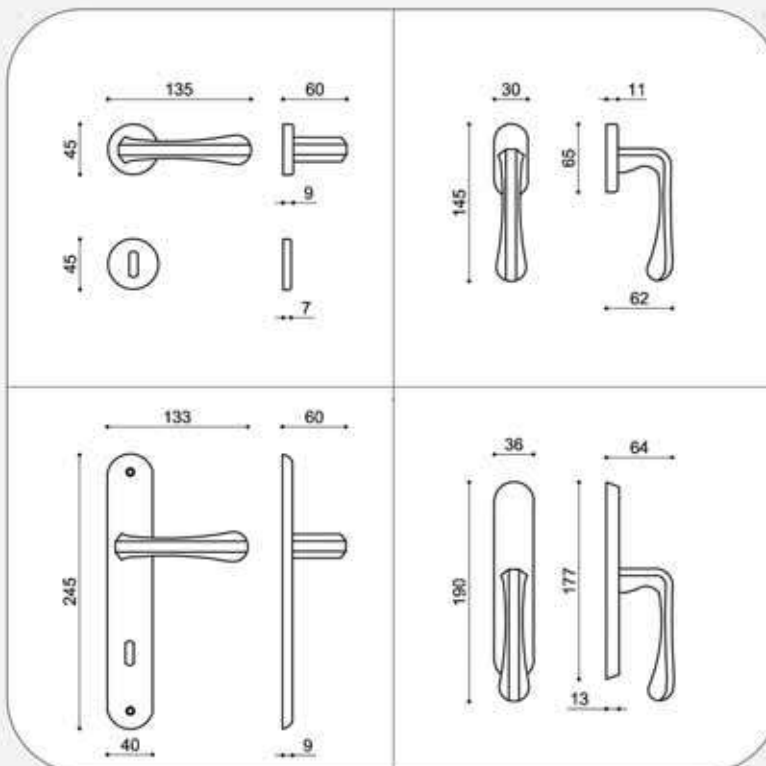

Rosetta standard:
R45 rosetta tonda d. 45 mm

Varianti:
R50 rosetta tonda d. 50 mm
RO rosetta ovale mm 30x60
nottolino Wc abbinato da pag. 320

Dry keep standard:
D dry keep ovale con mov. in metallo
7x42 mm con boccole art. 1672 pag. 364

Placca standard:
distanza 70/90/yale/Wc art. P102 pag. 358

Martellina standard:
placca art. P108 pag. 359 con movimento
rinforzato art. 1559 pag. 365

Cremonese standard:
placca art. P108 pag. 359
movimento intercambiabile art. 1551R
pag.365

finiture:
OLV ottone lucido verniciato
ANT ottone bronzo antico
ORO ottone oro antico
ARG ottone argento antico
RAM ottone ramato antico

1790 Sofia

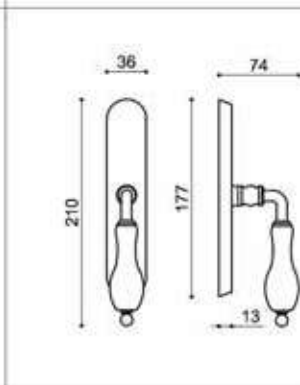
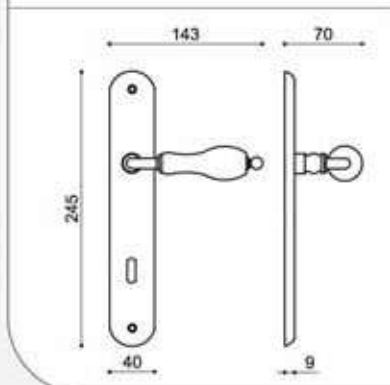
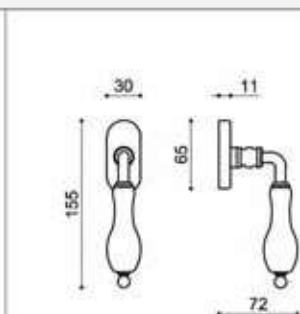
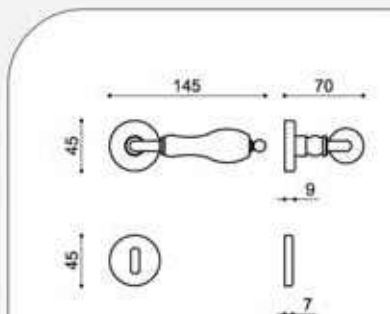

Rosetta standard:
R45 rosetta tonda d. 45 mm

Varianti:
R50 rosetta tonda d. 50 mm
RO rosetta ovale mm 30x60
nottolino Wc abbinato da pag. 320

Dry keep standard:
D dry keep ovale con mov. in metallo
7x42 mm con boccole art. 1672 pag. 364

Placca standard:
distanza 70/90/yale/Wc art. P102 pag. 358

Martellina standard:
placca art. P108 pag. 359 con movimento
rinforzato art. 1559 pag. 365

Cremonese standard:
placca art. P108 pag. 359
movimento intercambiabile art. 1551R pag. 365

finiture:
OLV ottone lucido verniciato
SV ottone satinato verniciato
CS ottone cromato satinato
CR ottone cromato lucido
ANT ottone bronzo antico
BG ottone bronzato graffiato

1791 Diamantea

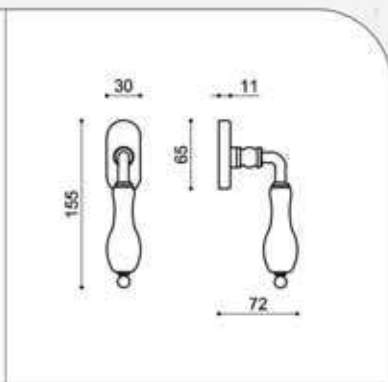
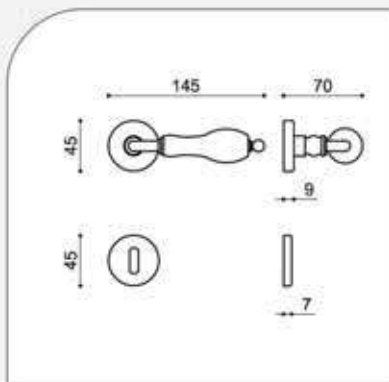

Rosetta standard:
R45 rosetta tonda d. 45 mm

Varianti:
R50 rosetta tonda d. 50 mm
RO rosetta ovale mm 30x60
nottolino Wc abbinato da pag. 320

Dry keep standard:
D dry keep ovale con mov. in metallo
7x42 mm con boccole art. 1672 pag. 364

Placca standard:
distanza 70/90/yale/Wc art. P102 pag. 358

Martellina standard:
placca art. P108 pag. 359 con movimento
rinforzato art. 1559 pag. 365

Cremonese standard:
placca art. P108 pag. 359
movimento intercambiabile art. 1551R pag.365

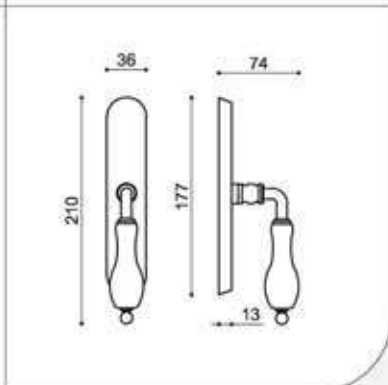
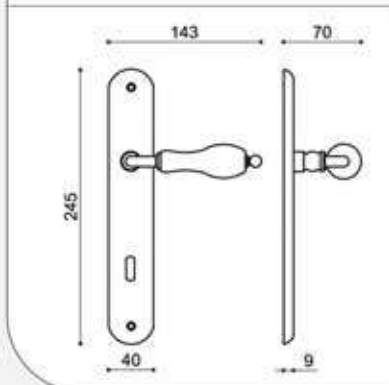

finiture:
OLV ottone lucido verniciato
SV ottone satinato verniciato
CS ottone cromato satinato
CR ottone cromato lucido
ANT ottone bronzo antico
BG ottone bronzato graffiato

1792 Camelia

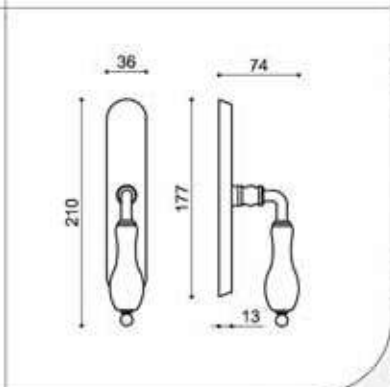
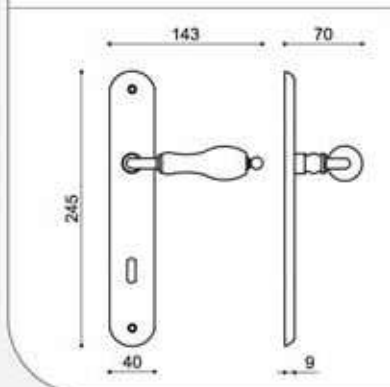
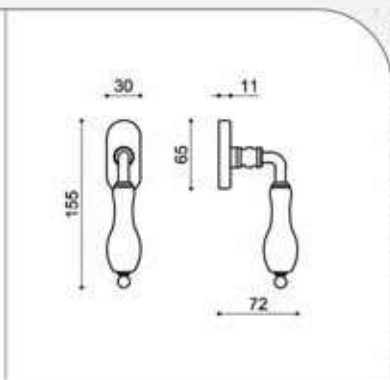
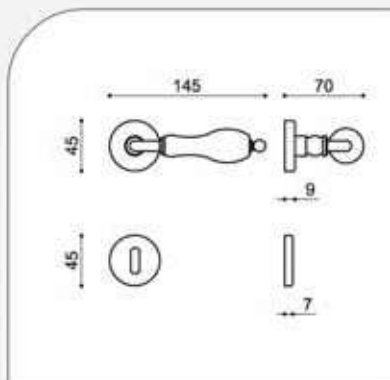
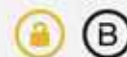

Rosetta standard:
R45 rosetta tonda d. 45 mm

Varianti:
R50 rosetta tonda d. 50 mm
RO rosetta ovale mm 30x60
nottolino Wc abbinato da pag. 320

Dry keep standard:
D dry keep ovale con mov. in metallo
7x42 mm con boccole art. 1672 pag. 364

Placca standard:
distanza 70/90/yale/Wc art. P102 pag. 358

Martellina standard:
placca art. P108 pag. 359 con movimento
rinforzato art. 1559 pag. 365

Cremonese standard:
placca art. P108 pag. 359
movimento intercambiabile art. 1551R pag.365

finiture:
OLV ottone lucido verniciato
SV ottone satinato verniciato
CS ottone cromato satinato
CR ottone cromato lucido
ANT ottone bronzo antico
BG ottone bronzato graffiato

1793 Scalea

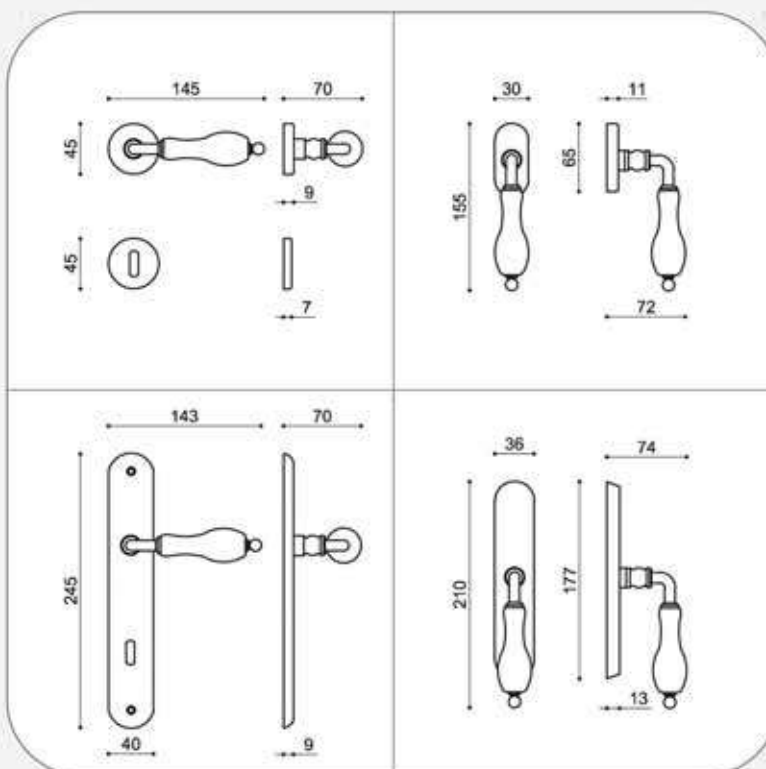

Rosetta standard:
R45 rosetta tonda d. 45 mm

Varianti:
R50 rosetta tonda d. 50 mm
RO rosetta ovale mm 30x60
nottolino Wc abbinato da pag. 320

Dry keep standard:
D dry keep ovale con mov. in metallo
7x42 mm con boccole art. 1672 pag. 364

Placca standard:
distanza 70/90/yale/Wc art. P102 pag. 358

Martellina standard:
placca art. P108 pag. 359 con movimento
rinforzato art. 1559 pag. 365

Cremonese standard:
placca art. P108 pag. 359
movimento intercambiabile art. 1551R pag.365

finiture:
OLV ottone lucido verniciato
SV ottone satinato verniciato
CS ottone cromato satinato
CR ottone cromato lucido
ANT ottone bronzo antico
BG ottone bronzato graffiato

179 CB collo basso

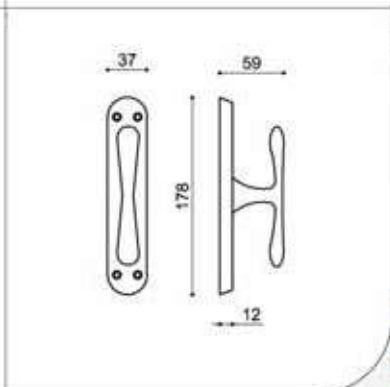
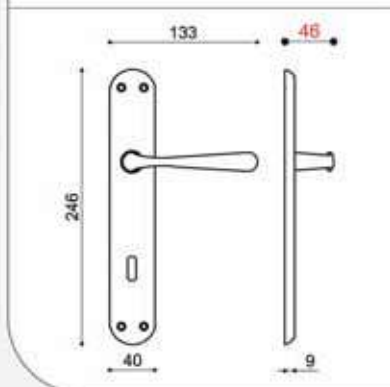
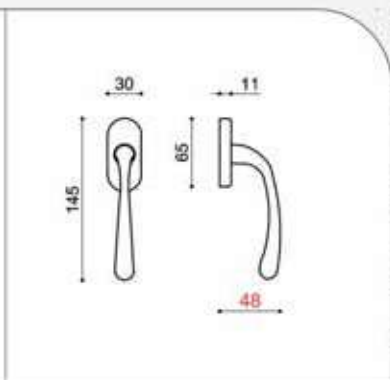
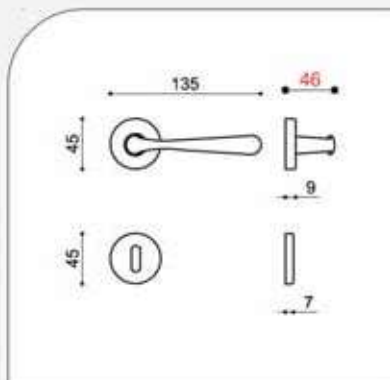

Rosetta standard:
R45 rosetta tonda d. 45 mm

Varianti:
RO rosetta ovale mm 30x60
nottolino Wc abbinato da pag. 320

Dry keep standard:
D dry keep ovale con mov. in metallo
7x42 mm con boccole art. 1672 pag. 364

Placca standard:
distanza 70/90/yale/Wc art. P101 pag. 358

Martellina standard:
placca art. P106 pag. 359 con quadro 7

Cremonese standard:
placca art. P106 pag. 359
movimento intercambiabile art. 1551 pag.365

finiture:
MORO maritech oro lucido
MCS maritech cromato satinato
MCR maritech cromato lucido
MNKS maritech nickel satinato verniciato

164 Anello salva muro

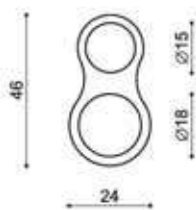

Anello di protezione da applicare sull'impugnatura della maniglia per evitare collisioni e urti nella fase di apertura della porta



finiture:
PVC pvc trasparente

161 Ovalino MP

Ⓑ

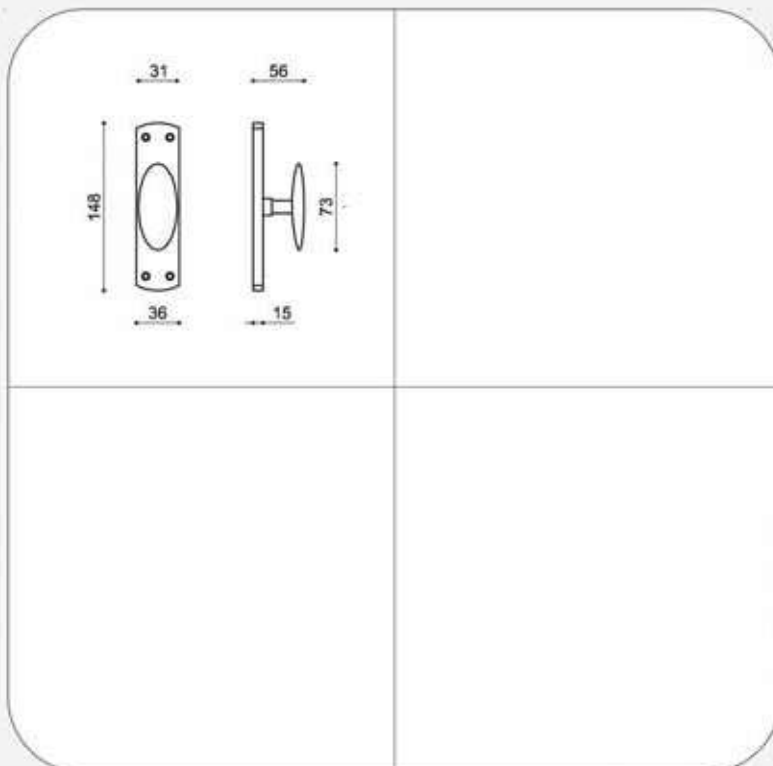

standard:
movimento con perni corti art. 1557 pag. 365

finiture:
OLV ottone lucido verniciato
SV ottone satinato verniciato
CS ottone cromato satinato
CR ottone cromato lucido
ANT ottone bronzo antico
ORO ottone oro antico
ARG ottone argento antico
RAM ottone ramato antico
BG ottone bronzato graffiato
NO ottone nero opaco
NL ottone nero lucido

161T Ovalino MP

Ⓑ

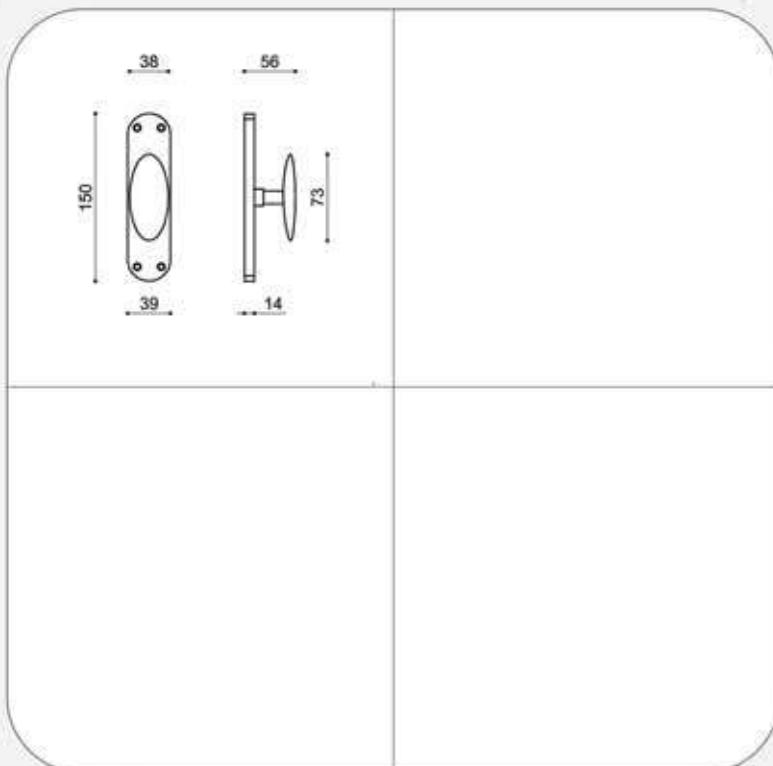

standard:
movimento con perni corti art. 1557 pag. 365

finiture:
OLV ottone lucido verniciato
SV ottone satinato verniciato
CS ottone cromato satinato
CR ottone cromato lucido
ANT ottone bronzo antico
ORO ottone oro antico
ARG ottone argento antico
RAM ottone ramato antico
BG ottone bronzato graffiato
NO ottone nero opaco
NL ottone nero lucido

163 Ovalino R

ⓑ

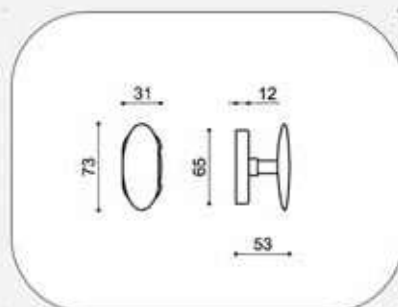

standard:
ovalino su rosetta ovale con quadro 7 girevole a martellina

- finiture:**
- OLV ottone lucido verniciato
 - SV ottone satinato verniciato
 - CS ottone cromato satinato
 - CR ottone cromato lucido
 - ANT ottone bronzo antico
 - ORO ottone oro antico
 - ARG ottone argento antico
 - RAM ottone ramato antico
 - BG ottone bronzato graffiato
 - NO ottone nero opaco
 - NL ottone nero lucido

162 Incontro ovalino

ⓑ

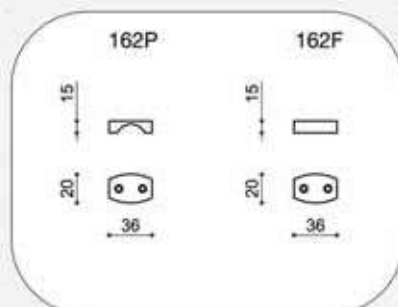

versioni
162P : incontro passante
162F : incontro finale

- finiture:**
- OLV ottone lucido verniciato
 - SV ottone satinato verniciato
 - CS ottone cromato satinato
 - CR ottone cromato lucido
 - ANT ottone bronzo antico
 - ORO ottone oro antico
 - ARG ottone argento antico
 - RAM ottone ramato antico
 - BG ottone bronzato graffiato
 - NO ottone nero opaco
 - NL ottone nero lucido

Riferimenti rosette tonde

Placca per maniglia

pagina 358

Placca per martellina/cremonese

pagina 359

Rosette e bocchette tonde diametro 45 mm

pagina 361

Rosette e bocchette tonde diametro 50 mm

pagina 360

Rosette e bocchette tonde lusso

pagina 363

Rosette e bocchette ovali













pagina 361

Nottolini Wc tondi e ovali

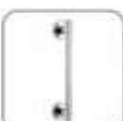
da pagina 320





-  **182**
Stilo
pag. 134
-  **183**
Stilo lungo
pag. 135
-  **190**
Lotus
pag. 136
-  **191**
Sonic
pag. 137
-  **192**
Square
pag. 138
-  **193**
Zonta
pag. 139
-  **194**
Honey
pag. 140
-  **195**
Tesa
pag. 141
-  **196**
Nives
pag. 142
-  **200**
Apollo
pag. 143
-  **180**
Studio
pag. 132
-  **181**
Studio zancato
pag. 133

Maniglioni



201
Soffio
pag. 144



202
Luna
pag. 145



203
Splendid
pag. 146



203B
Splendid B
pag. 147



204
Adry
pag. 148



205
Garda
pag. 149



206
Idea
pag. 150



206B
Idea B
pag. 151



207
Classic
pag. 152



208
Eclisse
pag. 153



209
Aurelia
pag. 154



209Z
Aurelia zancato
pag. 155



210
Bingo
pag. 156



210B
Bingo B
pag. 157



211
Mito
pag. 158



211B
Mito B
pag. 159



212 200
Arco 200
pag. 160



212 300
Arco 300
pag. 161



213
Margherita
pag. 162



214
Clara
pag. 163



215
Lisso
pag. 164



215B
Lisso B
pag. 165



216
Light
pag. 166



217
Easy
pag. 167



218
Spigola
pag. 168



219
Spigola Lungo
pag. 169



620HG
Staffa
pag. 170



620HS
Staffa HS
pag. 171



620HP
Staffa HP
pag. 172



138PY
Spirit PY
pag. 173

180 Studio

Ⓑ

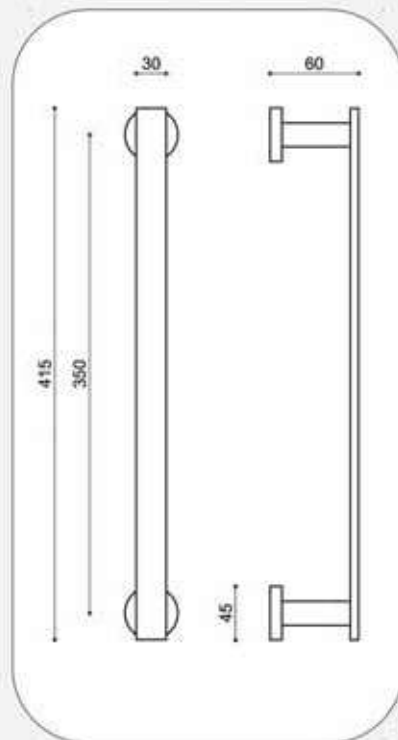
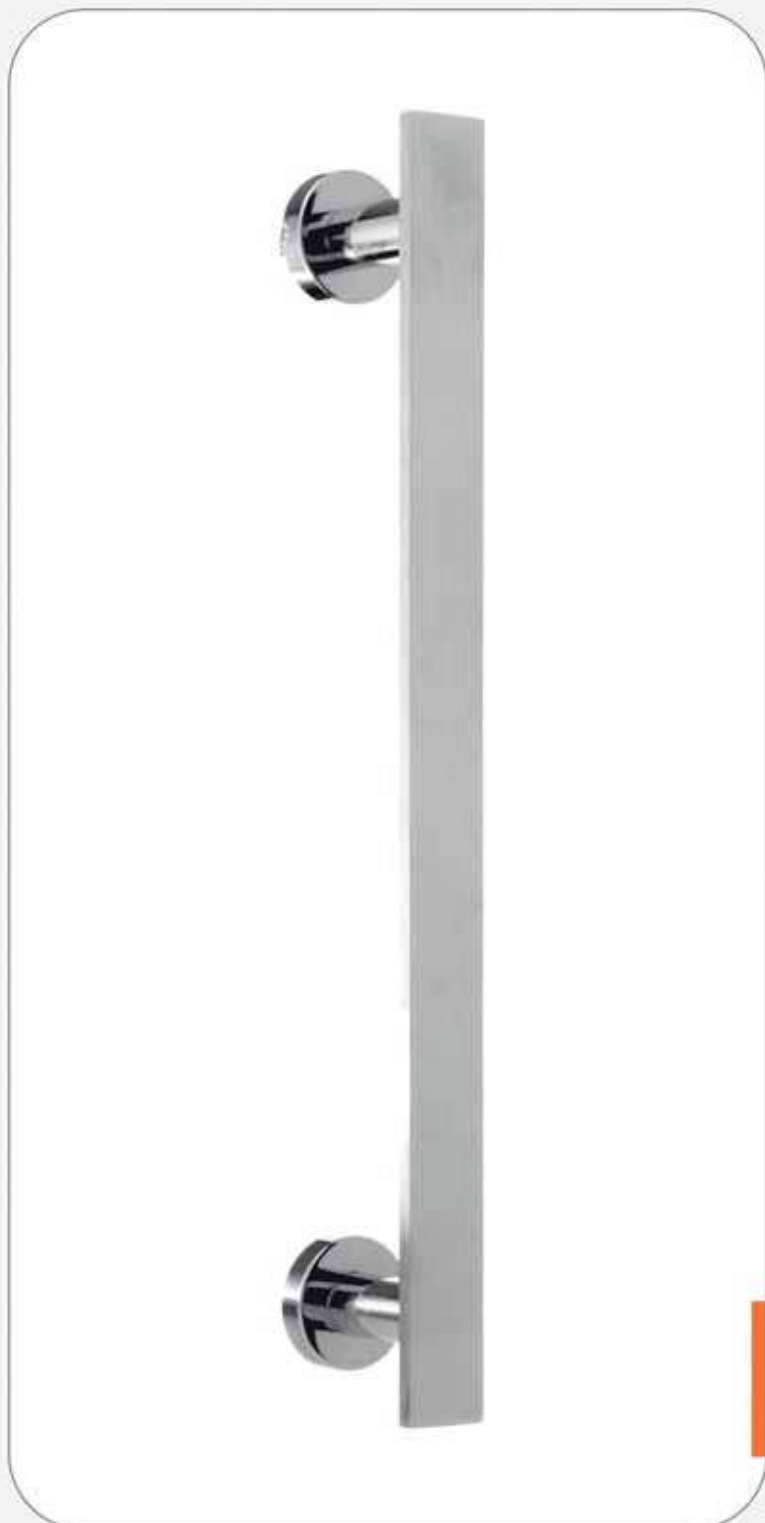

interasse maniglione:
art. 180 : interasse mm 350

modello accoppiato:
modello accoppiato art. 180C
modello accoppiato per vetro su richiesta

finiture:
CS ottone cromato satinato
CR ottone cromato lucido
CR/CS ottone bicolore cromo/satinato

181 Studio zancato

Ⓑ

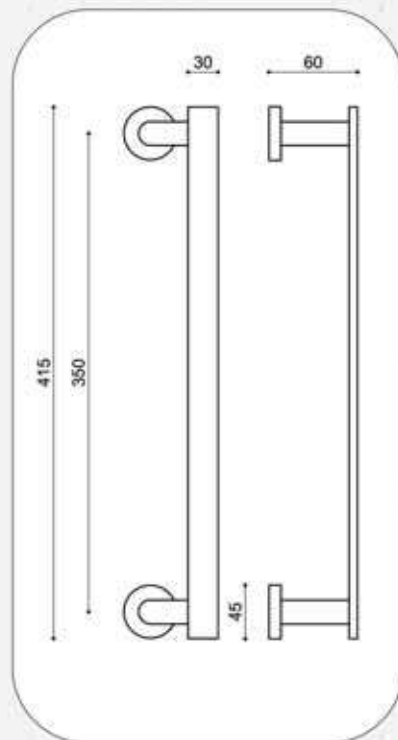
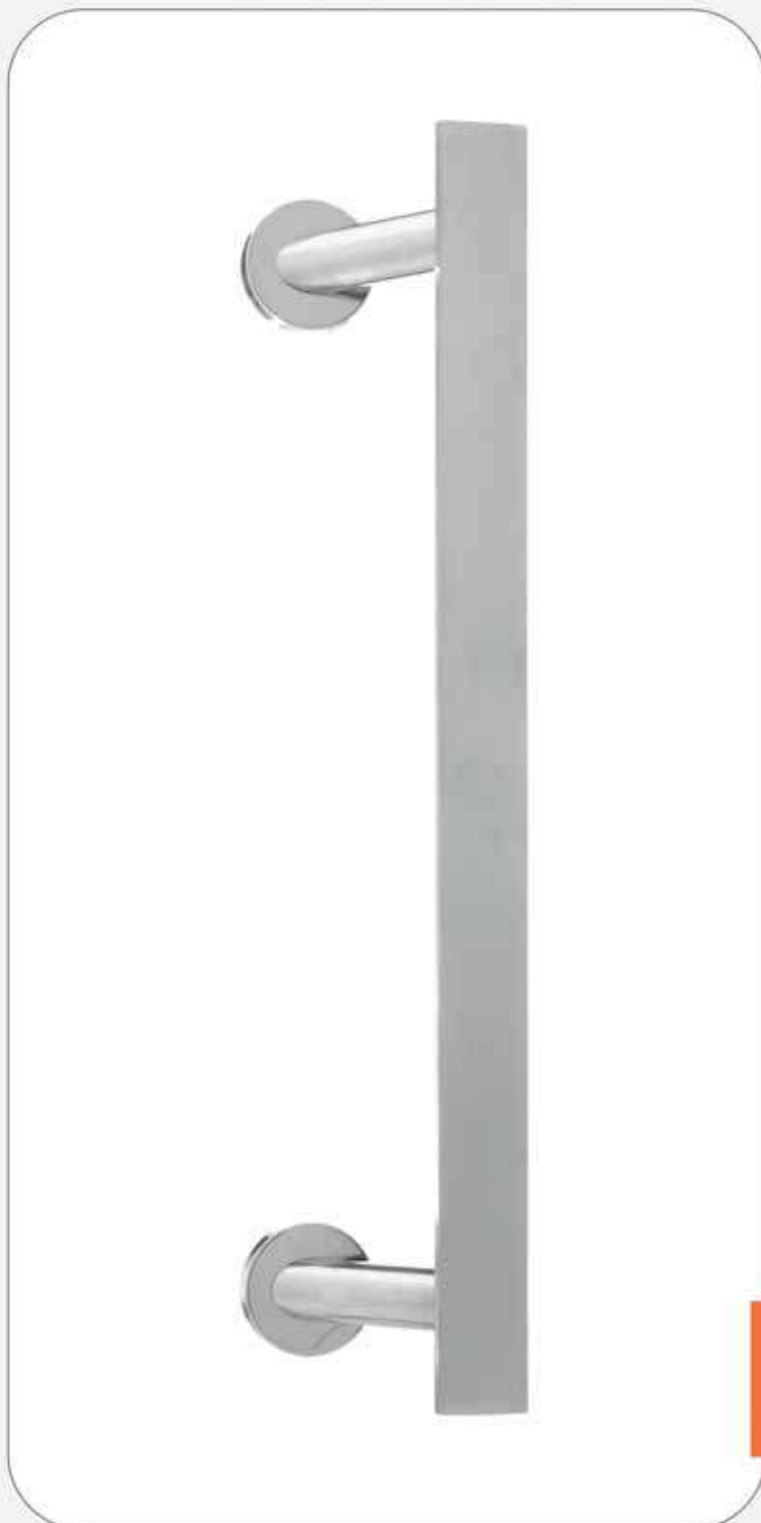

interasse maniglione:
art. 181 : interasse mm 350

modello accoppiato:
modello accoppiato art. 181C
modello accoppiato per vetro su richiesta

finiture:
CS ottone cromato satinato
CR ottone cromato lucido
CR/CS ottone bicolore cromo/satinato

182 Stilo

Ⓑ

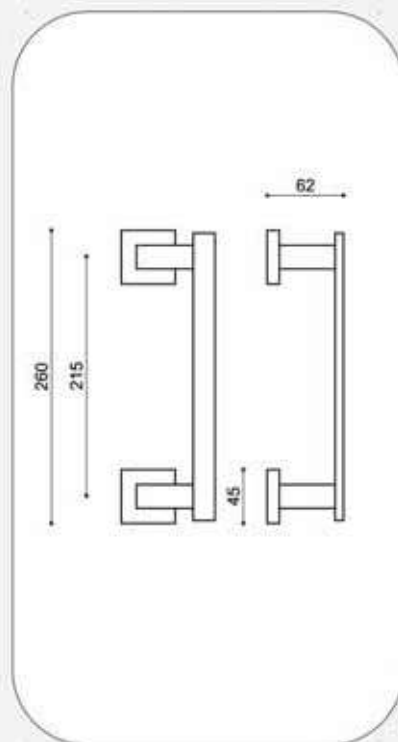
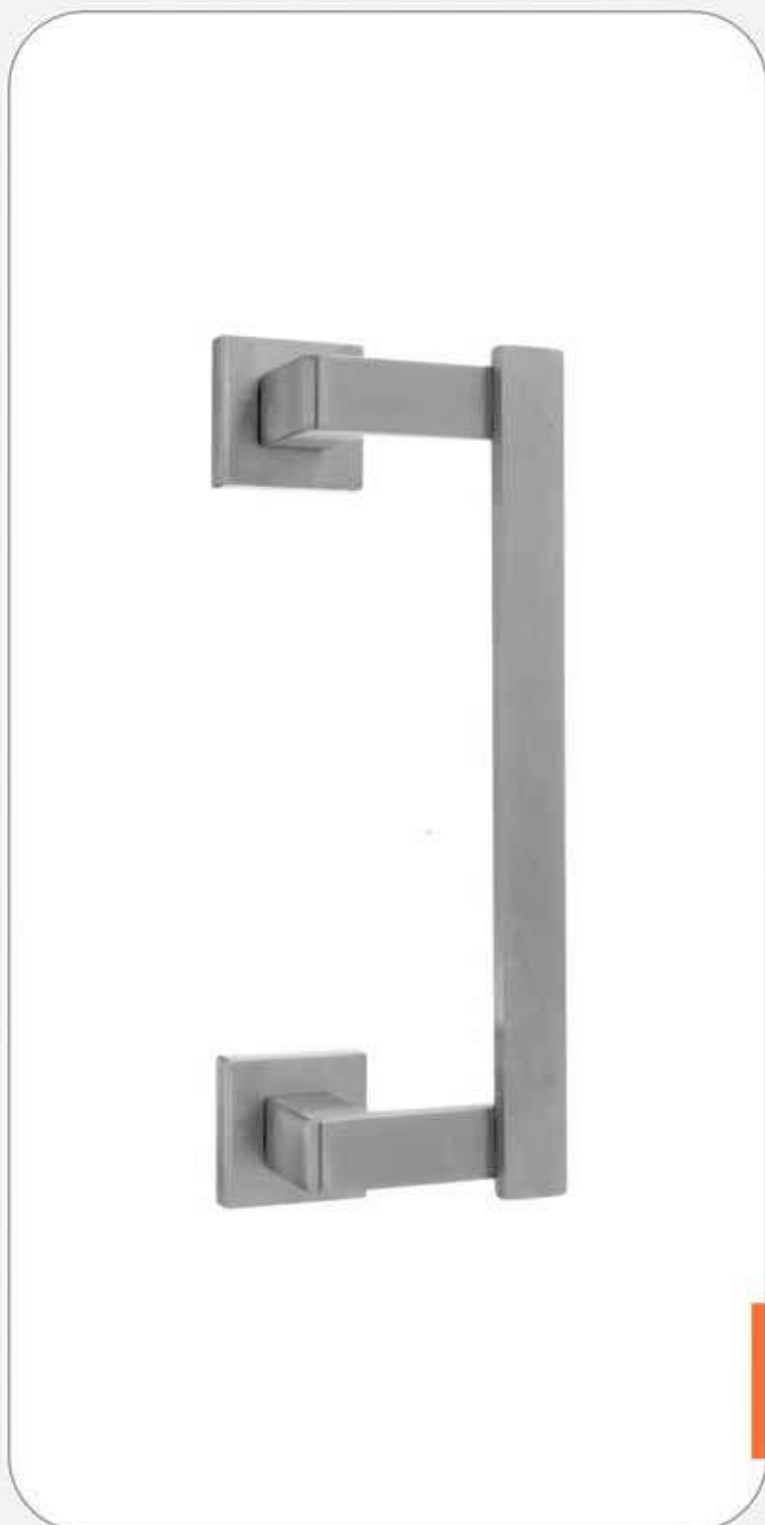

interasse maniglione:
art. 182 : interasse mm 215

modello accoppiato:
modello accoppiato art. 182C
modello accoppiato per vetro su richiesta

varianti:
con rosette rettangolari art. 182RR

finiture:
CS ottone cromato satinato
CR ottone cromato lucido
CR/CS ottone bicolore cromo/satinato

183 Stilo lungo

Ⓑ

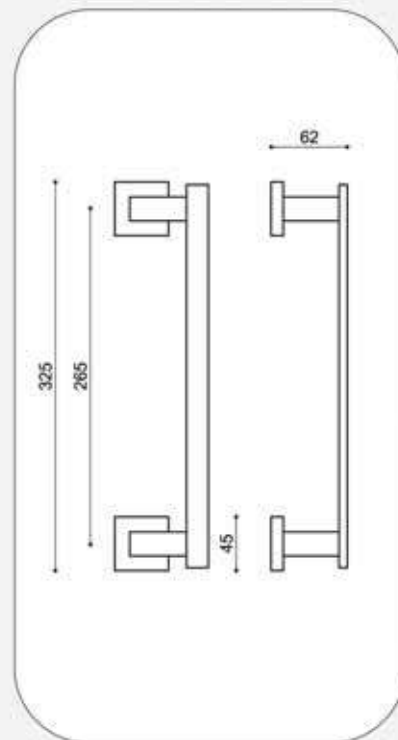
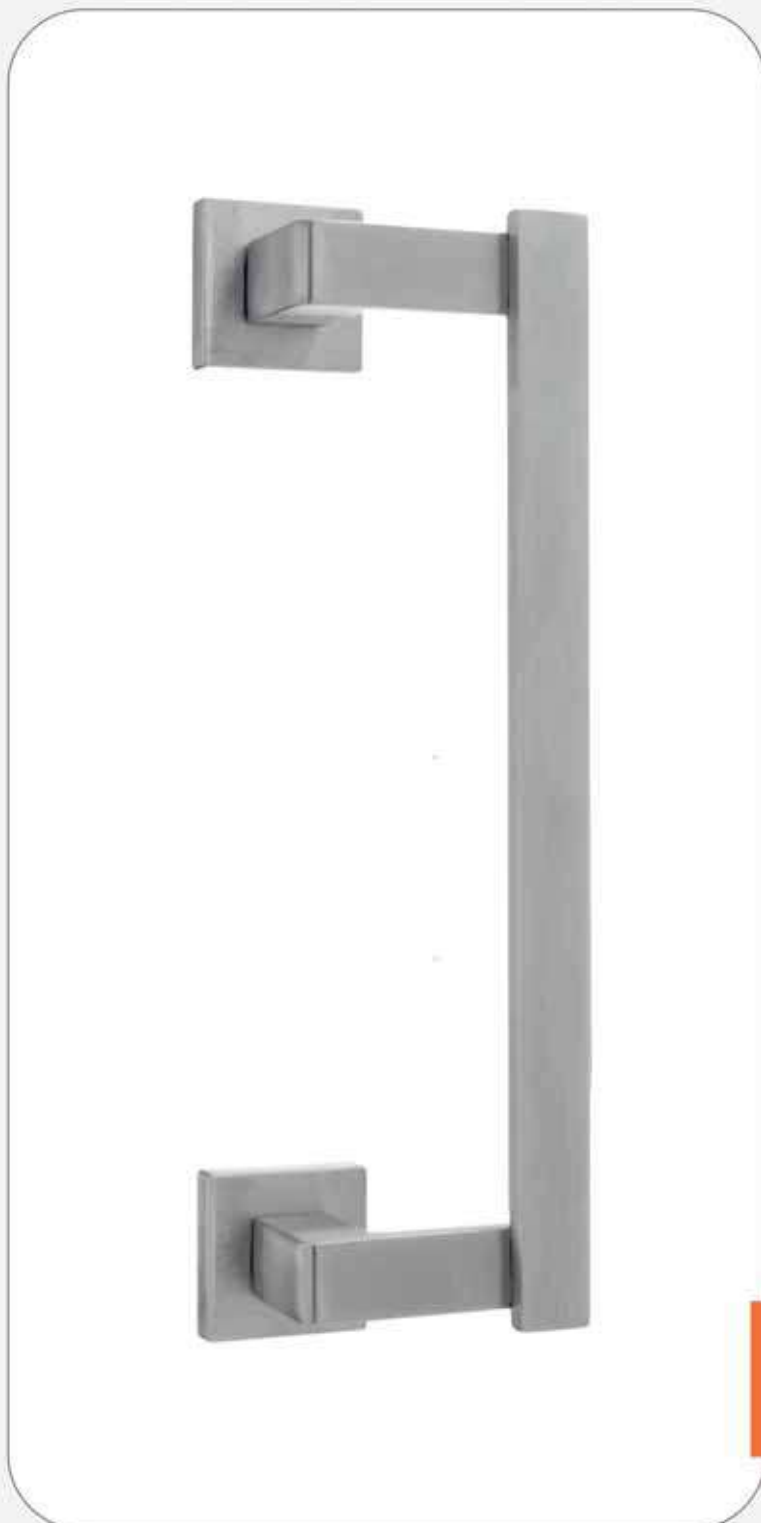

interasse maniglione:
art. 183 : interasse mm 265

modello accoppiato:
modello accoppiato art. 183C
modello accoppiato per vetro su richiesta

varianti:
con rosette rettangolari art. 183RR

finiture:
CS ottone cromato satinato
CR ottone cromato lucido
CR/CS ottone bicolore cromo/satinato

190 Lotus

Ⓑ

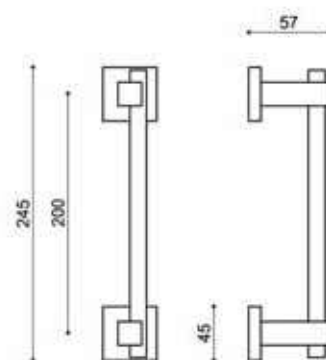

interasse maniglione:
art. 190 : interasse mm 200

modello accoppiato:
modello accoppiato art. 190C
modello accoppiato per vetro su richiesta.

varianti:
con rosette rettangolari art. 190RR
senza rosette art. 190SR

finiture:
CS ottone cromato satinato
CR ottone cromato lucido
CR/CS ottone bicolore cromo/satinato

191 Sonic

Ⓑ

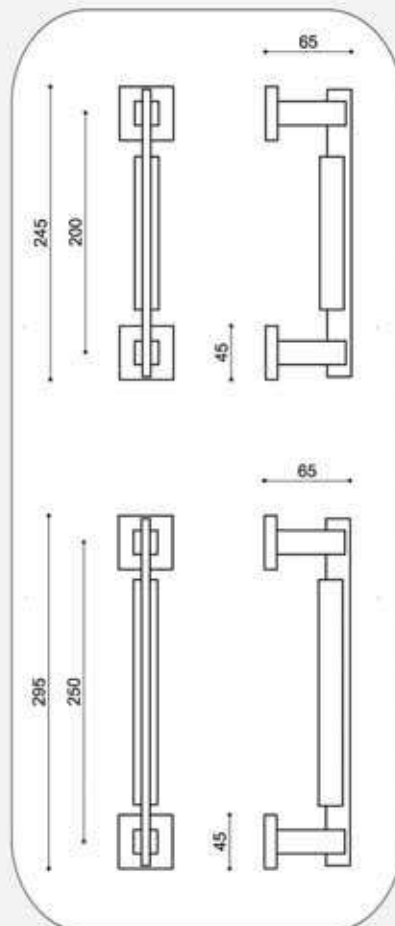

interasse maniglione:
art. 191 200: interasse mm 200
art. 191 300: interasse mm 250

modello accoppiato:
modello accoppiato art. 191 200C
modello accoppiato art. 191 300C
modello accoppiato per vetro su richiesta

varianti:
con rosette rettangolari art. 191 200RR
con rosette rettangolari art. 191 300RR
senza rosette art. 191 200SR
senza rosette art. 191 300SR

finiture:
CS ottone cromato satinato
CR ottone cromato lucido
CR/CS ottone bicolore cromo/satinato

192 Square

Ⓑ

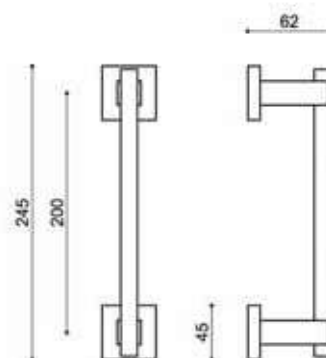

interasse maniglione:
art. 192 : interasse mm 200

modello accoppiato:
modello accoppiato art. 192C
modello accoppiato per vetro su richiesta

varianti:
con rosette rettangolari art. 192RR
senza rosette art. 192SR

finiture:
CS ottone cromato satinato
CR ottone cromato lucido
CR/CS ottone bicolore cromo/satinato

193 Zonta

Ⓑ

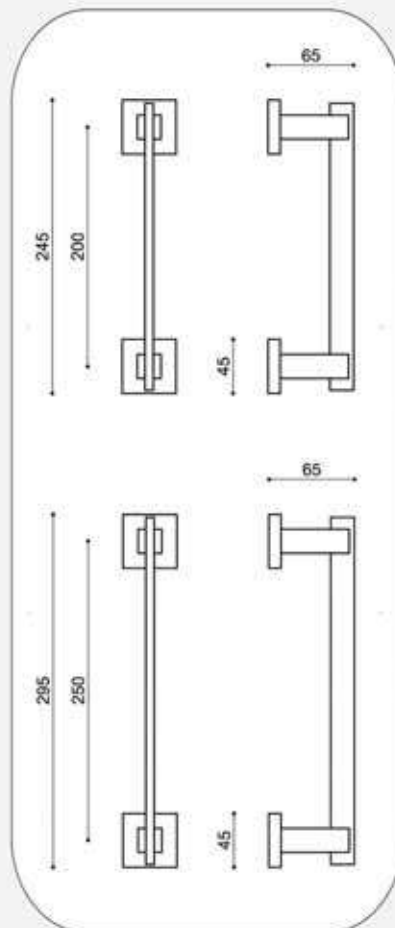

interasse maniglione:

art. 193 200: interasse mm 200
art. 193 300: interasse mm 250

modello accoppiato:

modello accoppiato art. 193 200C
modello accoppiato art. 193 300C
modello accoppiato per vetro su richiesta

varianti:

con rosette rettangolari art. 193 200RR
con rosette rettangolari art. 193 300RR
senza rosette art. 193 200SR
senza rosette art. 193 300SR

finiture:

CS ottone cromato satinato
CR ottone cromato lucido
CR/CS ottone bicolore cromo/satinato

194 Honey

Ⓑ

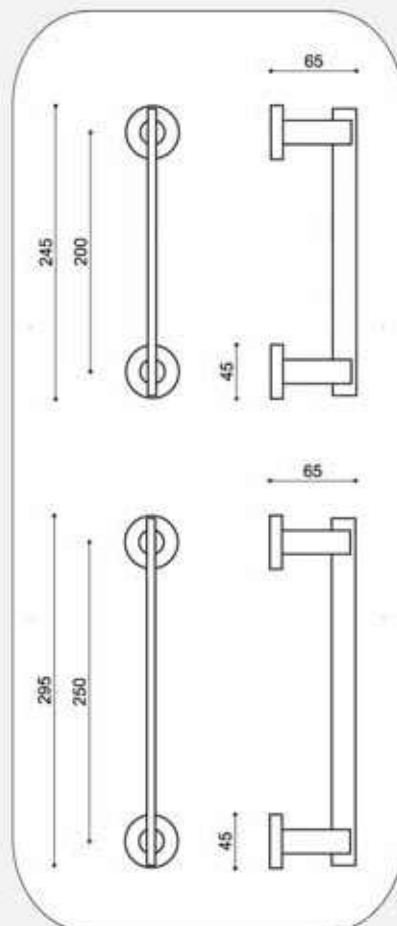

interasse maniglione:
art. 194 200: interasse mm 200
art. 194 300: interasse mm 250

modello accoppiato:
modello accoppiato art. 194 200C
modello accoppiato art. 194 300C
modello accoppiato per vetro su richiesta

varianti:
con rosette rettangolari art. 194 200RR
con rosette rettangolari art. 194 300RR
senza rosette art. 194 200SR
senza rosette art. 194 300SR

finiture:
CS ottone cromato satinato
CR ottone cromato lucido
CR/CS ottone bicolore cromo/satinato

195 Tesa

Ⓑ

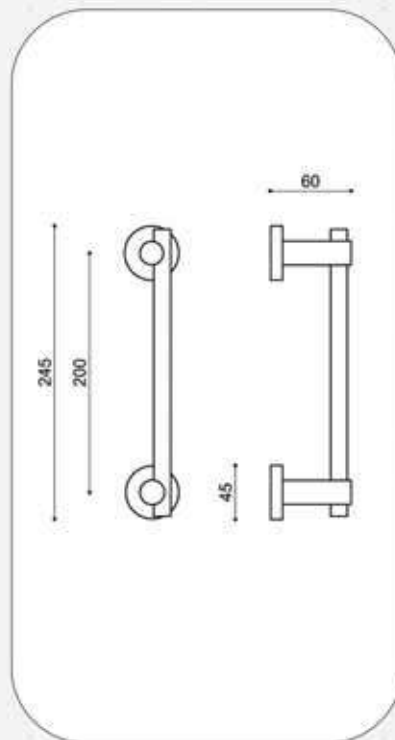

interasse maniglione:
art. 195 : interasse mm 200

modello accoppiato:
modello accoppiato art. 195C
modello accoppiato per vetro su richiesta

varianti:
con rosette ovali art. 195RO
senza rosette art. 195SR

finiture:
CS ottone cromato satinato
CR ottone cromato lucido
CR/CS ottone bicolore cromo/satinato

196 Nives

Ⓑ

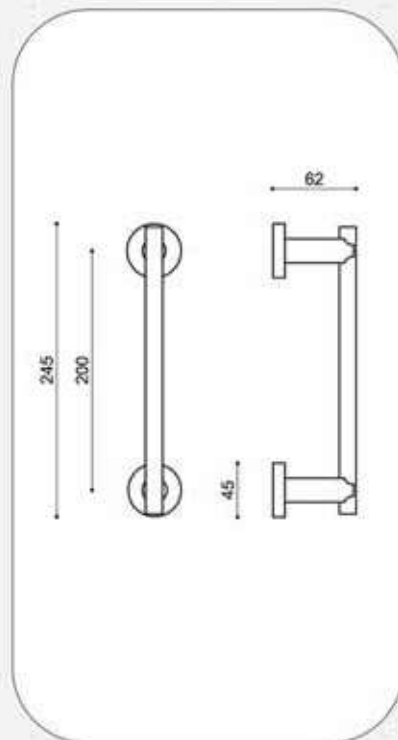

interasse maniglione:
art. 196 : interasse mm 200

modello accoppiato:
modello accoppiato art. 196C
modello accoppiato per vetro su richiesta.

varianti:
con rosette ovali art. 196RO
senza rosette art. 195SR

finiture:
CS ottone cromato satinato
CR ottone cromato lucido
CR/CS ottone bicolore cromo/satinato

200 Apollo

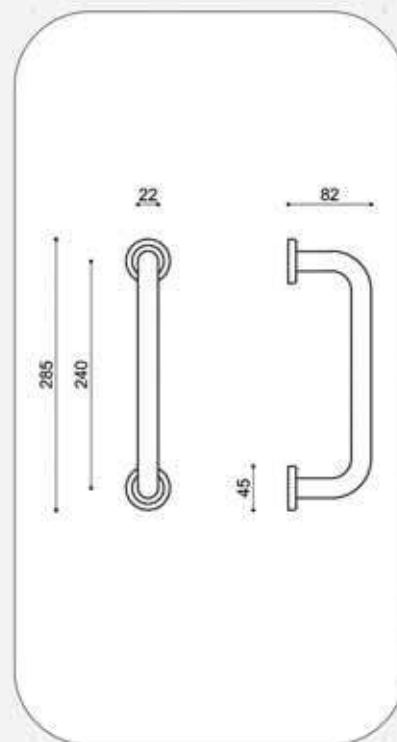
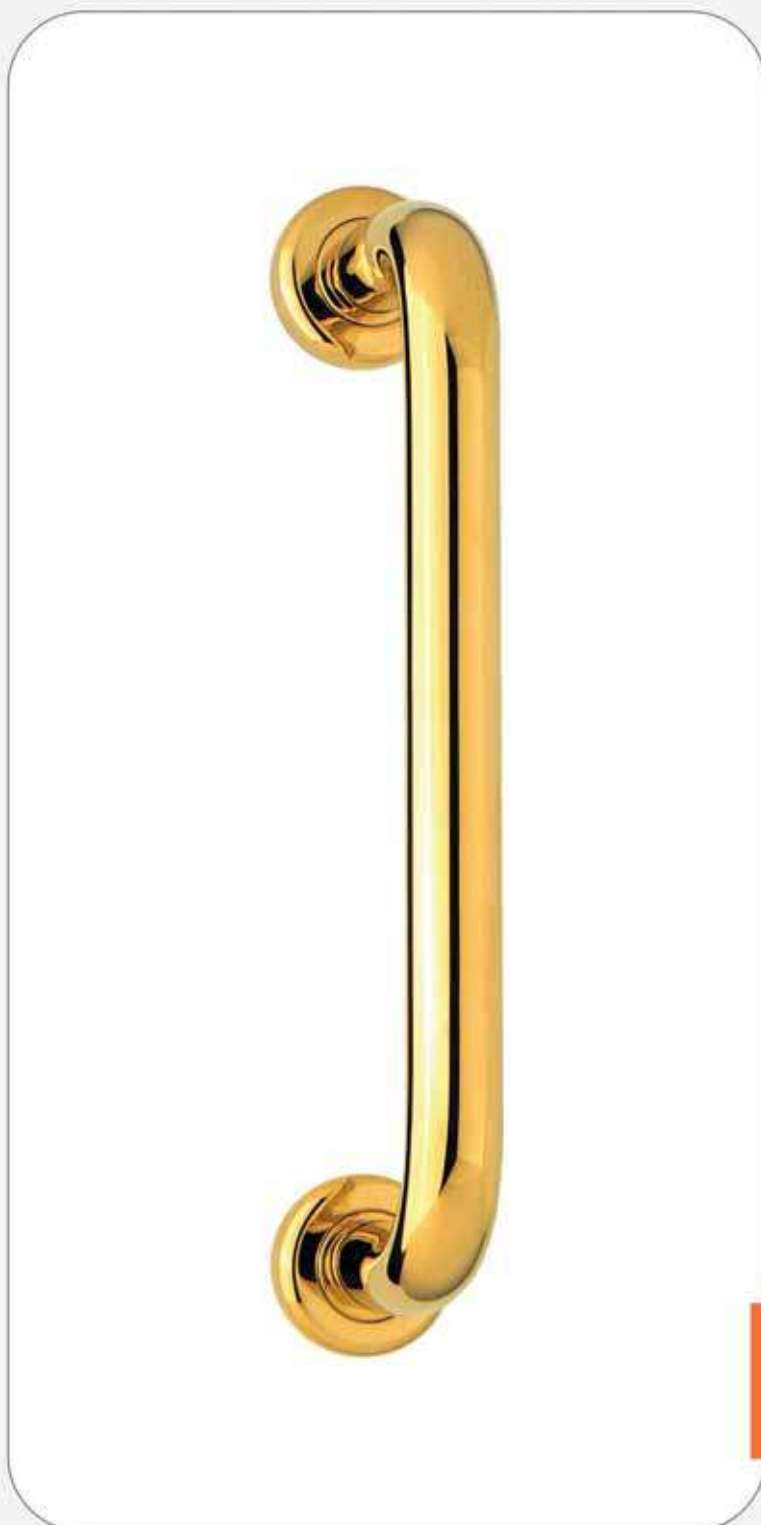

interasse maniglione:
art. 200 : interasse mm 240

modello accoppiato:
modello accoppiato art. 200C
modello accoppiato per vetro su richiesta

varianti:
con rosette ovali art. 200RO

finiture:
PVD ottone con trattamento PVD
OLV ottone lucido verniciato
SV ottone satinato verniciato
CS ottone cromato satinato
CR ottone cromato lucido
BG ottone bronzato graffiato

201 Soffio

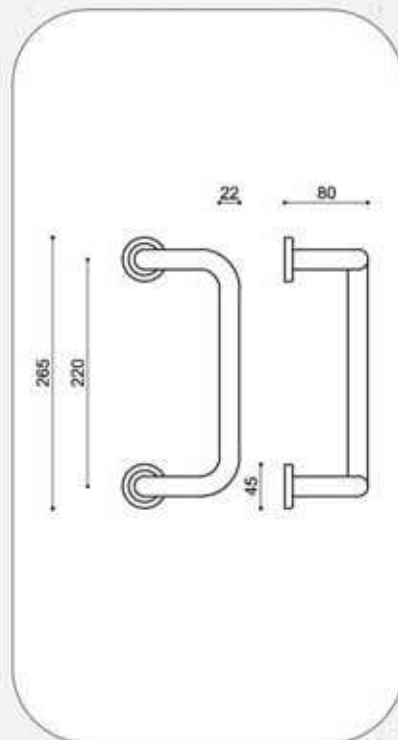

interasse maniglione:
art. 201 : interasse mm 220

modello accoppiato:
modello accoppiato art. 201C
modello accoppiato per vetro su richiesta.

varianti:
con rosette ovali art. 201RO

finiture:
PVD ottone con trattamento PVD
OLV ottone lucido verniciato
SV ottone satinato verniciato
CS ottone cromato satinato
CR ottone cromato lucido
BG ottone bronzato graffiato

202 Luna

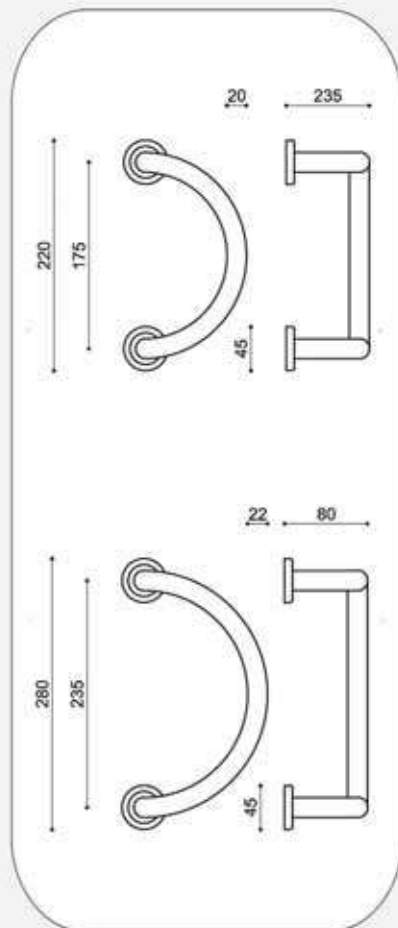

interasse maniglione:

art. 202 180 : interasse mm 175

art. 202 220 : interasse mm 235

modello accoppiato:

modello accoppiato art. 202 180C

modello accoppiato art. 202 220C

modello accoppiato per vetro su richiesta

varianti:

con rosette ovali art. 202 180RO

con rosette ovali art. 202 220RO

finiture:

PVD ottone con trattamento PVD

OLV ottone lucido verniciato

CS ottone cromato satinato

CR ottone cromato lucido

BG ottone bronzato graffiato

203 Splendid

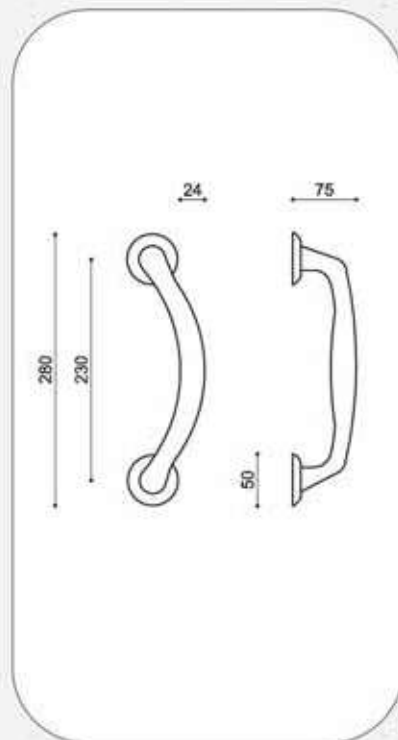

interasse maniglione:
art. 203 : interasse mm 230

modello accoppiato:
modello accoppiato art. 203C
modello accoppiato per vetro su richiesta.

- finiture:**
- PVD ottone con trattamento PVD
 - INOX ottone con trattamento PVD INOX
 - OLV ottone lucido verniciato
 - SV ottone satinato verniciato
 - CS ottone cromato satinato
 - CR ottone cromato lucido
 - ANT ottone bronzato antico
 - ORO ottone oro antico
 - ARG ottone argento antico
 - BG ottone bronzato graffiato

203B Splendid B

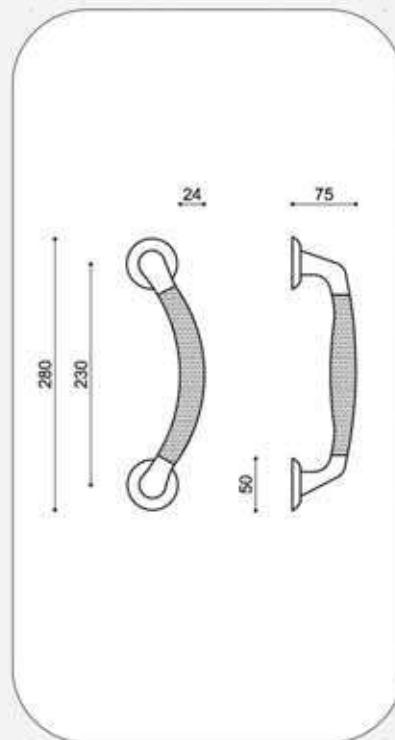

interasse maniglione:
art. 203B : interasse mm 230

modello accoppiato:
modello accoppiato art. 203BC
modello accoppiato per vetro su richiesta

finiture:
PVD/SAT ottone bi colore con tratt. PVD/SAT

OLV/OLS ottone bicolore lucido/satinato
CR/CS ottone bicolore cromo/satinato

204 Adry

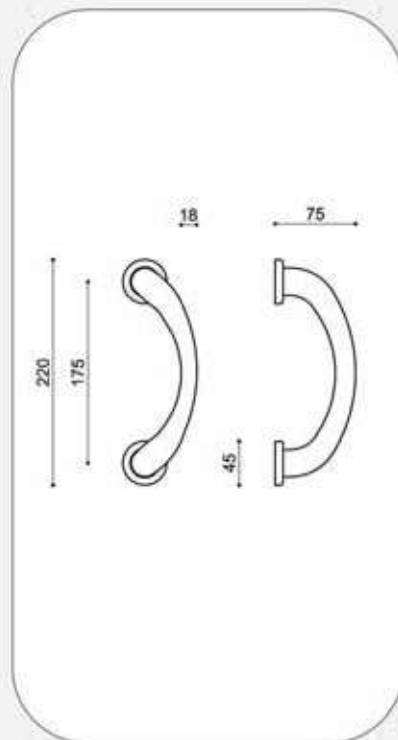

interasse maniglione:
art. 204 : interasse mm 175

modello accoppiato:
modello accoppiato art. 204C
modello accoppiato per vetro su richiesta.

- finiture:**
- PVD ottone con trattamento PVD
 - INOX ottone con trattamento PVD INOX
 - OLV ottone lucido verniciato
 - SV ottone satinato verniciato
 - CS ottone cromato satinato
 - CR ottone cromato lucido
 - BG ottone bronzato graffiato

205 Garda

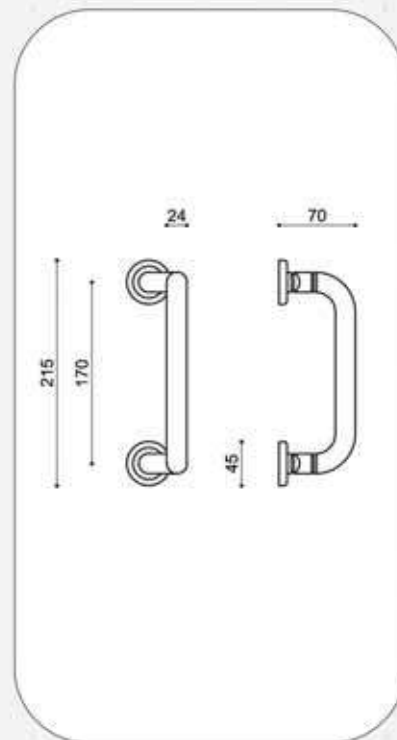

interasse maniglione:
art. 205 : interasse mm 170

varianti:
maniglione su placca P101 art. 205P

- finiture:**
- PVD ottone con trattamento PVD
 - OLV ottone lucido verniciato
 - SV ottone satinato verniciato
 - CS ottone cromato satinato
 - CR ottone cromato lucido
 - BG ottone bronzato graffiato

206 Idea

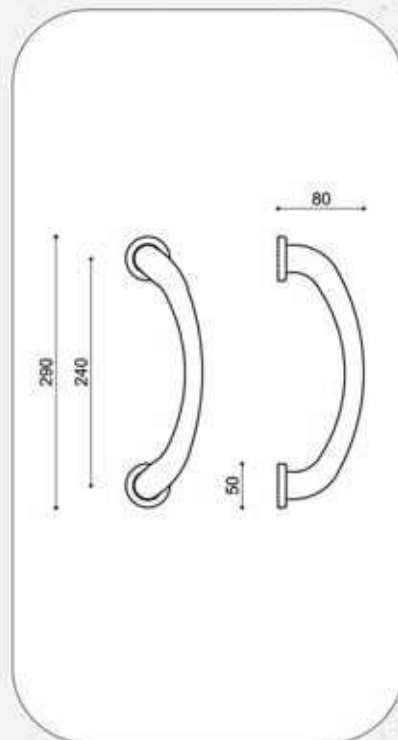

interasse maniglione:
art. 206 : interasse mm 240

modello accoppiato:
modello accoppiato art. 206C
modello accoppiato per vetro su richiesta.

- finiture:**
- PVD ottone con trattamento PVD
 - INOX ottone con trattamento INOX PVD
 - OLV ottone lucido verniciato
 - SV ottone satinato verniciato
 - CS ottone cromato satinato
 - CR ottone cromato lucido
 - BG ottone bronzato graffiato

206B Idea B

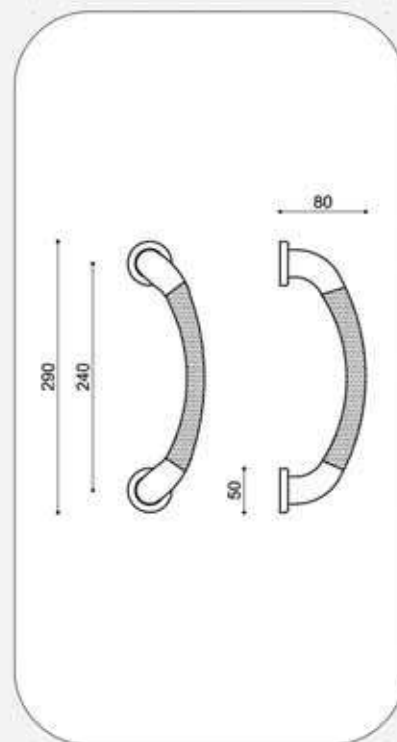
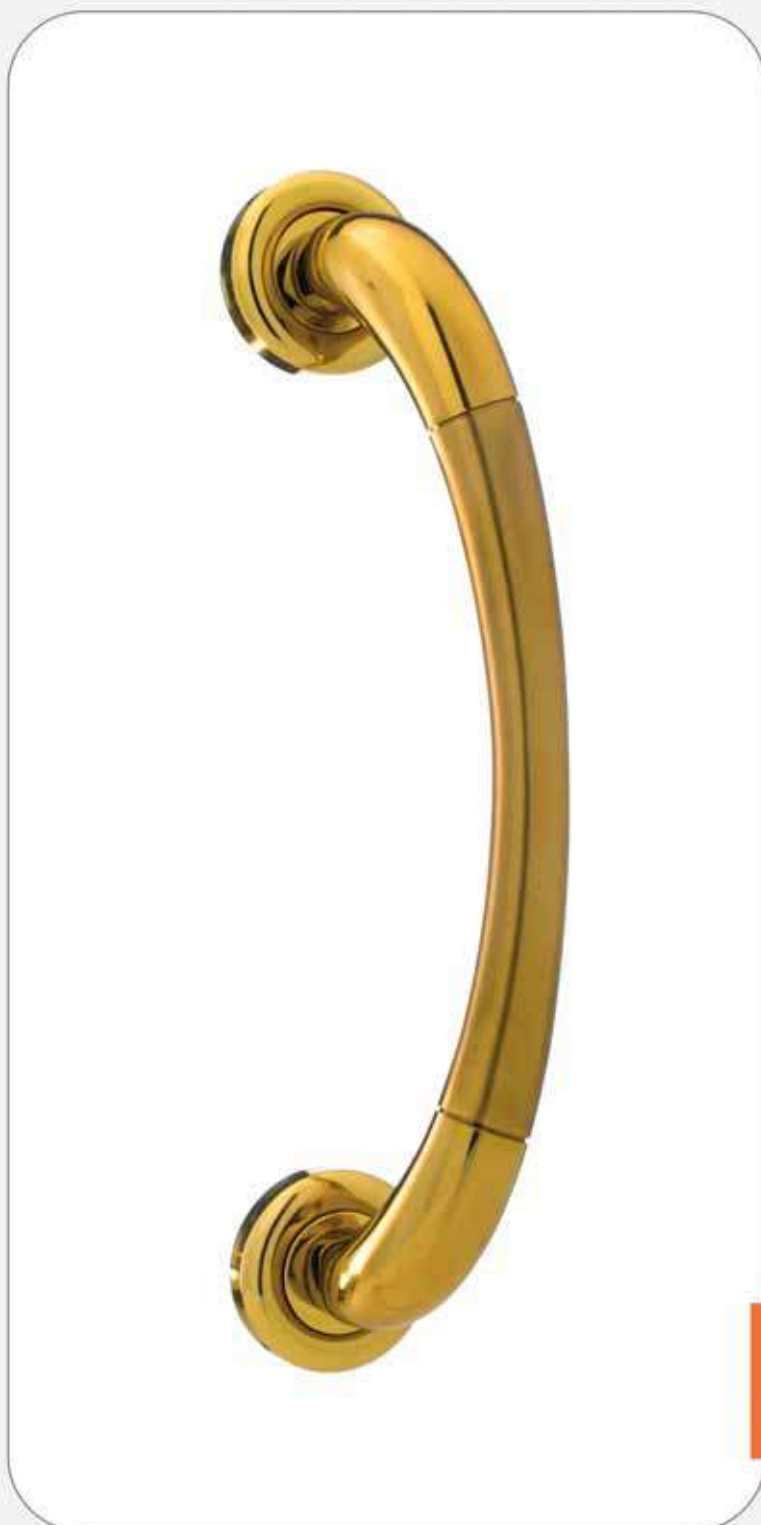

interasse maniglione:
art. 206B : interasse mm 240

modello accoppiato:
modello accoppiato art. 206BC
modello accoppiato per vetro su richiesta

finiture:
PVD/SAT ottone bi colore con tratt. PVD/SAT

OLV/OLS ottone bicolore lucido/satinato
CR/CS ottone bicolore cromo/satinato

207 Classic

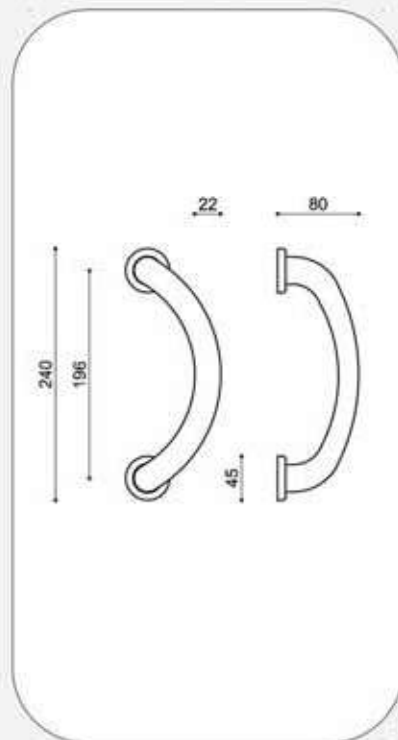

interasse maniglione:
art. 207 : interasse mm 196

modello accoppiato:
modello accoppiato art. 207C
modello accoppiato per vetro su richiesta

finiture:
PVD ottone con trattamento PVD
INOX ottone con trattamento PVD INOX

OLV ottone lucido verniciato
CS ottone cromato satinato
CR ottone cromato lucido
BG ottone bronzato graffiato

208 Eclisse

Ⓑ

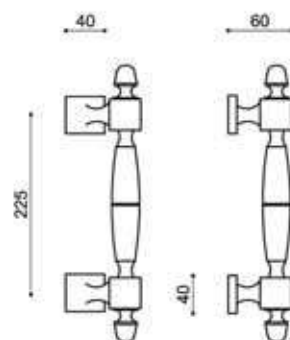

interasse maniglione:
art. 208 : interasse mm 225

fissaggio con perno passante

finiture:
OLV ottone lucido verniciato
BG ottone bronzato graffiato

209 Aurelia

Ⓑ

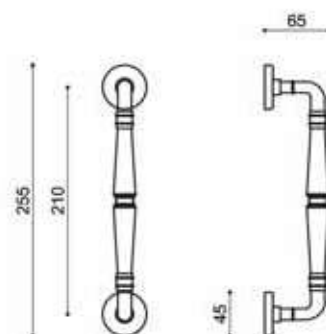

interasse maniglione:
art. 209 : interasse mm 210

varianti:
con rosette ovali art. 209RO

finiture:
OLV ottone lucido verniciato
CS ottone cromato satinato
CR ottone cromato lucido
ANT ottone bronzato antico
ORO ottone oro antico
ARG ottone argento antico
RAM ottone ramato antico
BG ottone bronzato graffiato

209Z Aurelia zancato

Ⓑ

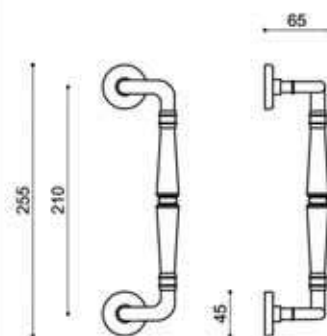

interasse maniglione:
art. 209Z : interasse mm 210

varianti:
con rosette ovali art. 209ZRO

finiture:

OLV	ottone lucido verniciato
CS	ottone cromato satinato
CR	ottone cromato lucido
ANT	ottone bronzato antico
ORO	ottone oro antico
ARG	ottone argento antico
RAM	ottone ramato antico
BG	ottone bronzato graffiato

210 Bingo

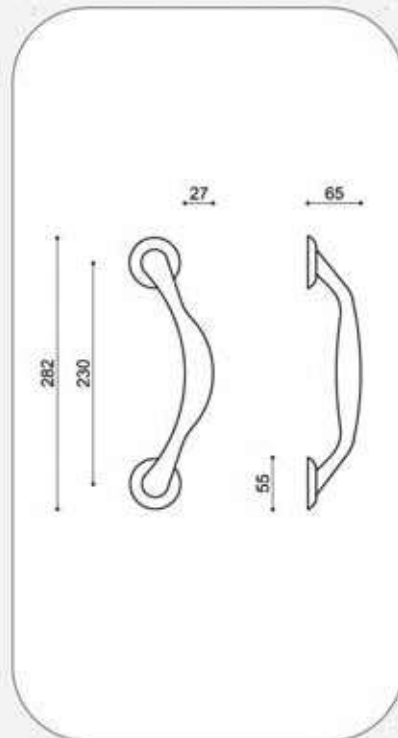

interasse maniglione:
art. 210 : interasse mm 230

finiture:

- PVD ottone con trattamento PVD
- INOX ottone con trattamento PVD INOX
- OLV ottone lucido verniciato
- SV ottone satinato verniciato
- CS ottone cromato satinato
- CR ottone cromato lucido
- ANT ottone bronzato antico
- ORO ottone oro antico
- ARG ottone argento antico
- RAM ottone ramato antico
- BG ottone bronzato graffiato

210B Bingo B

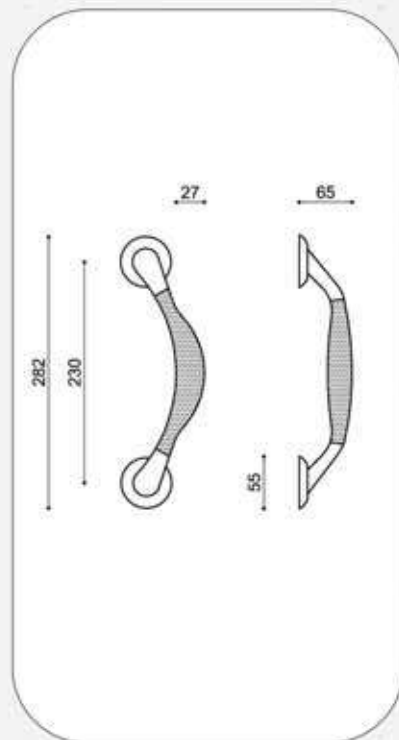

interasse maniglione:
art. 210B : interasse mm 230

finiture:
PVD/SAT ottone bi colore con tratt. PVD/SAT
OLV/OLS ottone bicolore lucido/satinato
CR/CS ottone bicolore cromo/satinato

211 Mito

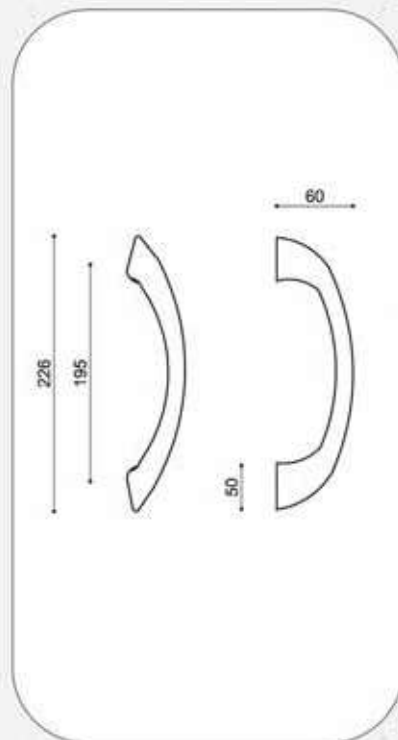

interasse maniglione:
art. 211 : interasse mm 196

modello accoppiato:
modello accoppiato art. 211C
modello accoppiato per vetro su richiesta.

finiture:

PVD ottone con trattamento PVD
INOX ottone con trattamento PVD INOX

OLV ottone lucido verniciato
SV ottone satinato verniciato
CS ottone cromato satinato
CR ottone cromato lucido
NKS ottone nikelato satinato verniciato
ANT ottone bronzato antico
ORO ottone oro antico
ARG ottone argento antico
RAM ottone ramato antico
BG ottone bronzato graffiato

211B Mito B

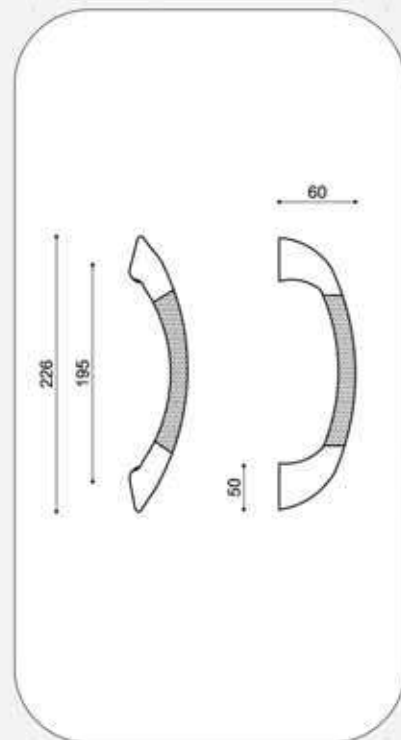

interasse maniglione:
art. 211B : interasse mm 196

modello accoppiato:
modello accoppiato art. 211BC
modello accoppiato per vetro su richiesta

finiture:
PVD/SAT ottone bi colore con tratt. PVD/SAT

OLV/OLS ottone bicolore lucido/satinato
CR/CS ottone bicolore cromo/satinato

212₂₀₀ Arco 200

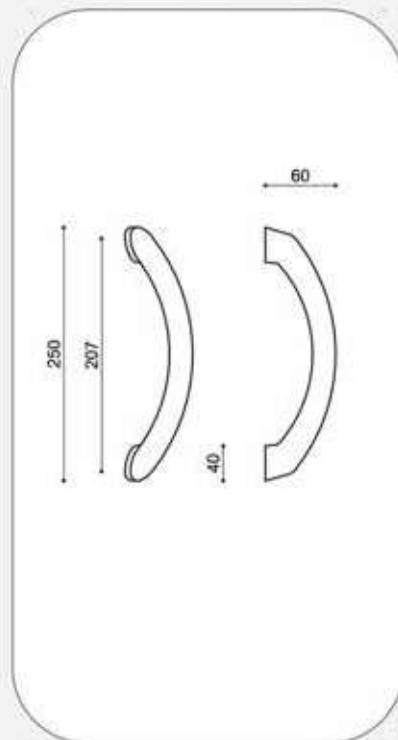
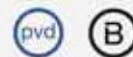

interasse maniglione:
art. 212 200 : interasse mm 207

modello accoppiato:
modello accoppiato art. 212 200C
modello accoppiato per vetro su richiesta

finiture:
PVD ottone con trattamento PVD
INOX ottone con trattamento PVD INOX
OLV ottone lucido verniciato
SV ottone satinato verniciato
CS ottone cromato satinato
CR ottone cromato lucido
BG ottone bronzato graffiato

212₃₀₀ Arco 300

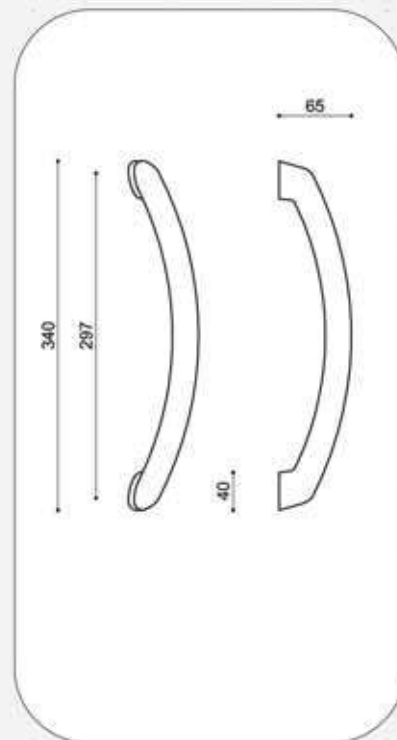

interasse maniglione:
art. 212 300 : interasse mm 297

modello accoppiato:
modello accoppiato art. 212 300C
modello accoppiato per vetro su richiesta

finiture:
PVD ottone con trattamento PVD
INOX ottone con trattamento PVD INOX

OLV ottone lucido verniciato
SV ottone satinato verniciato
CS ottone cromato satinato
CR ottone cromato lucido
BG ottone bronzato graffiato

213 Margherita

pvd B

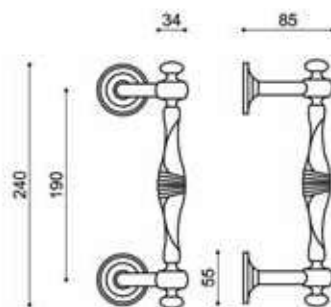

interasse maniglione:
art. 213 : interasse mm 190

finiture:
PVD ottone con trattamento PVD
OLV ottone lucido verniciato
CS ottone cromato satinato
ANT ottone bronzato antico
ORO ottone oro antico
ARG ottone argento antico
RAM ottone ramato antico
BG ottone bronzato graffiato

214 Clara

Ⓑ

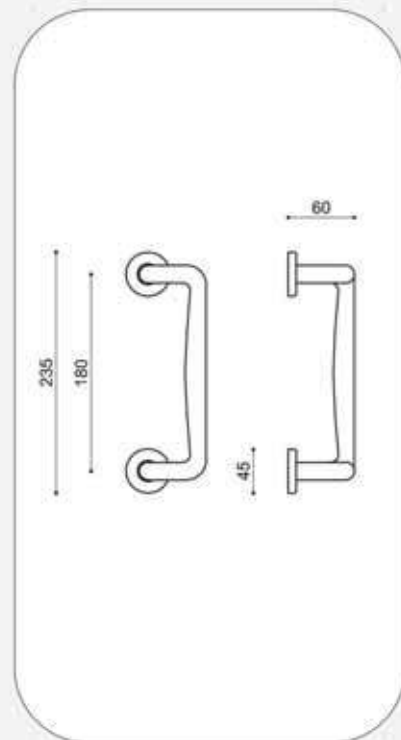

interasse maniglione:
art. 214 : interasse mm 180

finiture:
OLV ottone lucido verniciato
CS ottone cromato satinato
BG ottone bronzato graffiato

215 Lisso

Ⓑ

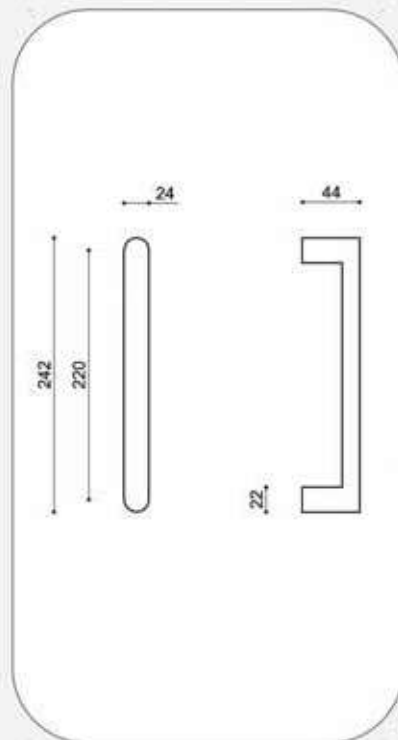
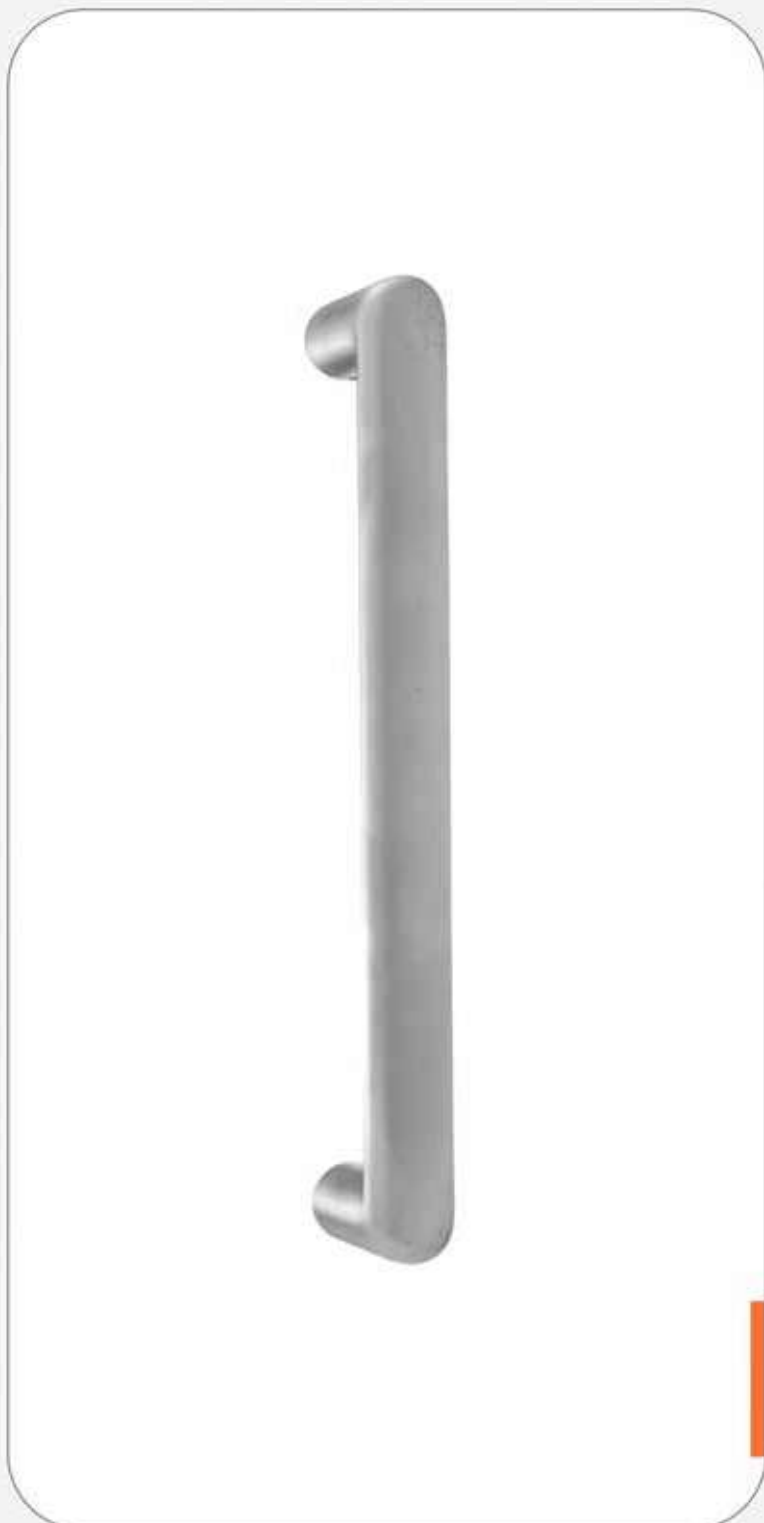

interasse maniglione:
art. 215 : interasse mm 220

modello accoppiato:
modello accoppiato art. 215C
modello accoppiato per vetro su richiesta.

varianti:
con rosette tonde d.45 mm art. 215R

finiture:
OLV ottone lucido verniciato
CS ottone cromato satinato
CR ottone cromato lucido

215B Lisso B

Ⓑ

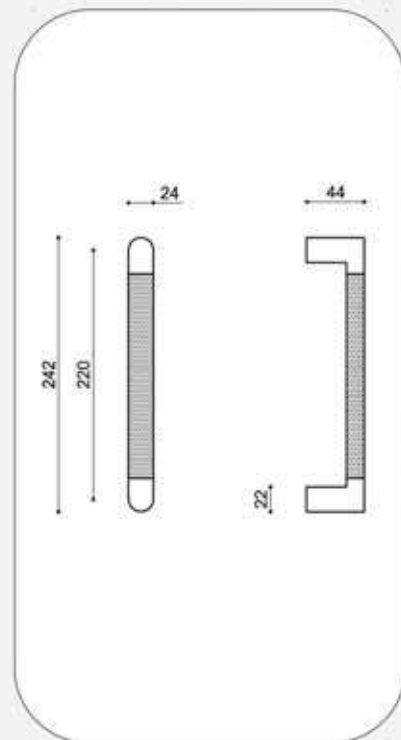
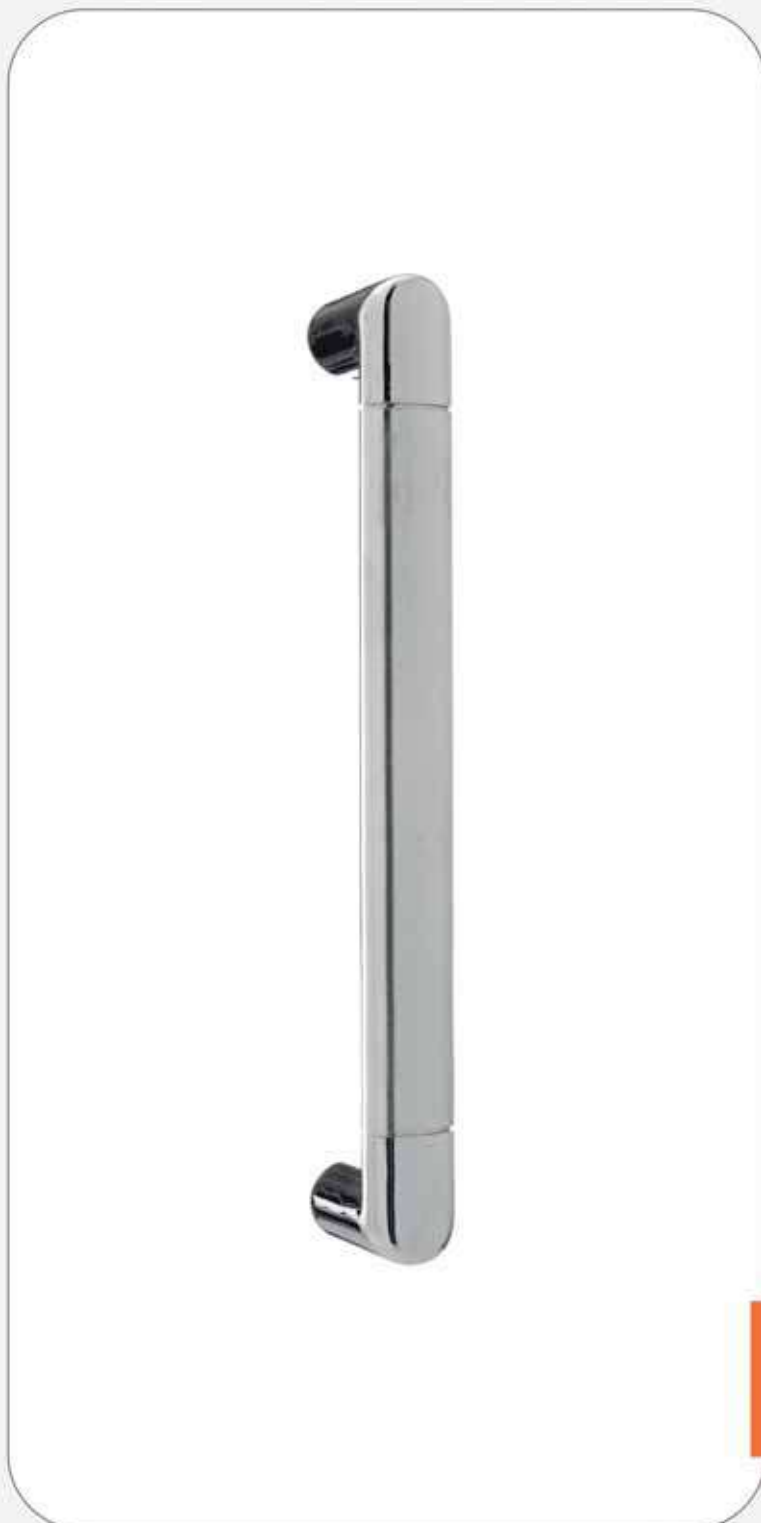

interasse maniglione:
art. 215B : interasse mm 220

modello accoppiato:
modello accoppiato art. 215BC
modello accoppiato per vetro su richiesta

varianti:
con rosette tonde d.45 mm art. 215BR

finiture:
OLV/OLS ottone bi colore lucido/satinato
CS/CS ottone bi colore cromosatinato

216 Light

Ⓑ

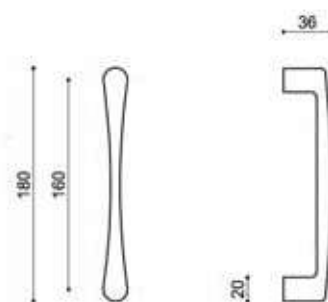
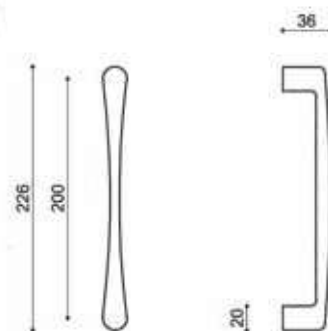

interasse maniglione:

art. 216 160 : interasse mm 160
art. 216 200 : interasse mm 200

modello accoppiato:

modello accoppiato art. 216 160C
modello accoppiato art. 216 200C
modello accoppiato per vetro su richiesta

finiture:

OLV ottone lucido verniciato
CS ottone cromato satinato
CR ottone cromato lucido
BG ottone bronzato graffiato

217 Easy

Ⓑ

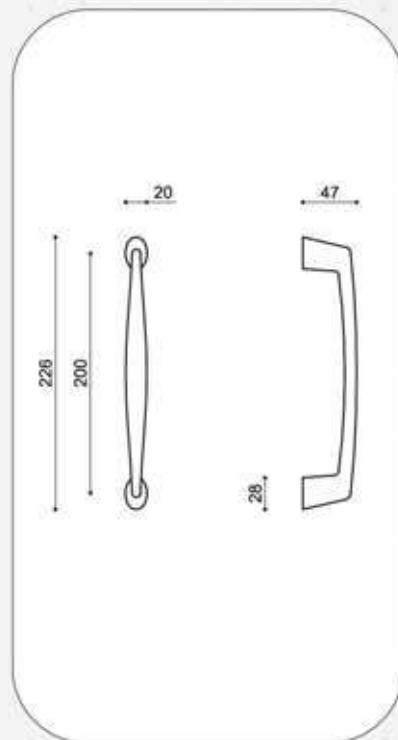

interasse maniglione:
art. 217 : interasse mm 200

modello accoppiato:
modello accoppiato art. 217C
modello accoppiato per vetro su richiesta

finiture:
OLV ottone lucido verniciato
CS ottone cromato satinato

218 Spigola

3

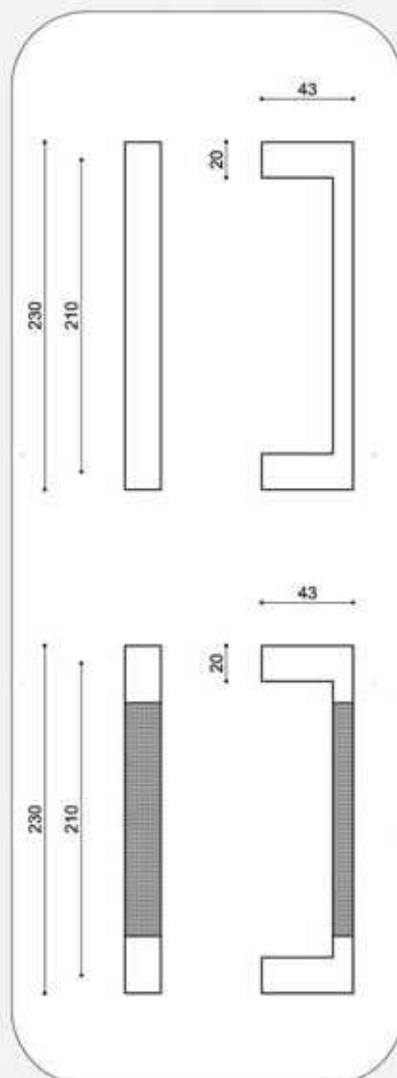

interasse maniglione:
art. 218 : interasse mm 210

modello accoppiato:
modello accoppiato art. 218C
modello accoppiato per vetro su richiesta

varianti:
con rosette quadre mm 45x45 art. 218RQ

finiture:
MCS maritech cromato satinato
MCR maritech cromato lucido
MCRCS maritech bi colore cromo/satinato

219 Spigola lungo

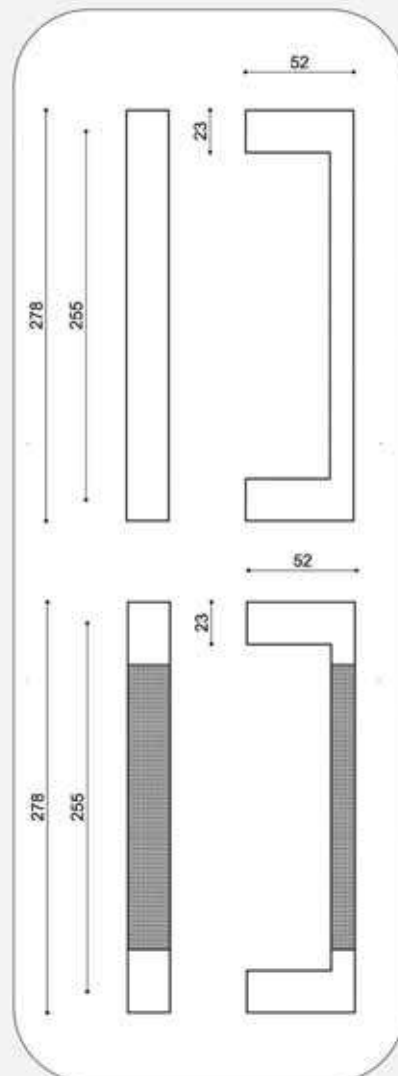
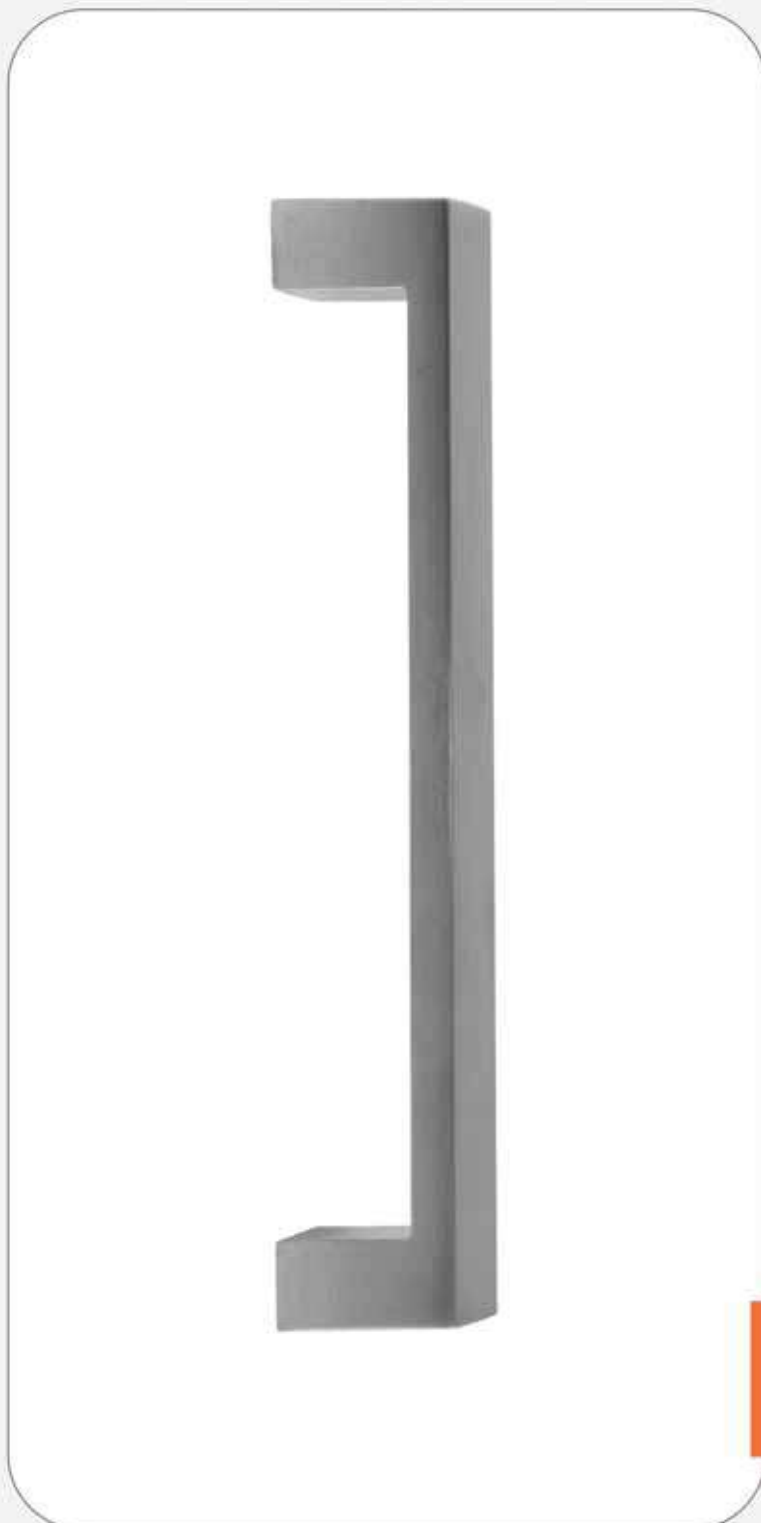

interasse maniglione:
art. 219 : interasse mm 255

modello accoppiato:
modello accoppiato art. 219C
modello accoppiato per vetro su richiesta

varianti:
con rosette quadre mm 45x45 art. 219RQ

finiture:
MCS maritech cromato satinato
MCR maritech cromato lucido
MCRCS maritech bi colore cromo/satinato

620_{HG} Staffa HG

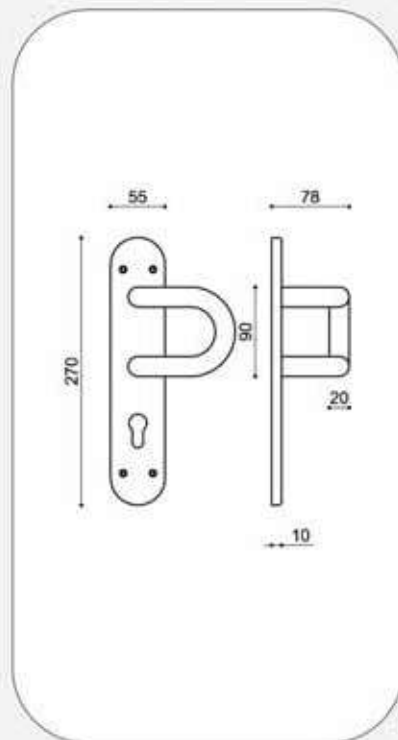

finiture:

- PVD ottone con trattamento PVD
- OLV ottone lucido verniciato
- CS ottone cromato satinato
- CR ottone cromato lucido
- BG ottone bronzato graffiato

620_{HS} Staffa HS

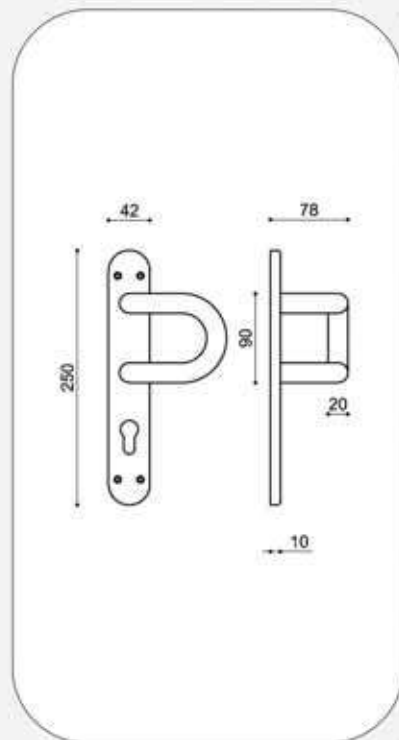

finiture:

PVD ottone con trattamento PVD

- OLV ottone lucido verniciato
- CS ottone cromato satinato
- CR ottone cromato lucido
- BG ottone bronzato graffiato

620_{HP} Staffa HP

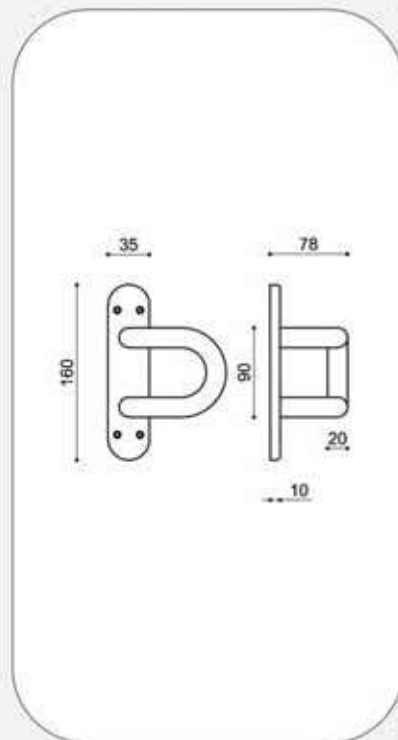

finiture:

PVD ottone con trattamento PVD

OLV ottone lucido verniciato

CS ottone cromato satinato

CR ottone cromato lucido

BG ottone bronzato graffiato

138^{PY} Spirit PY

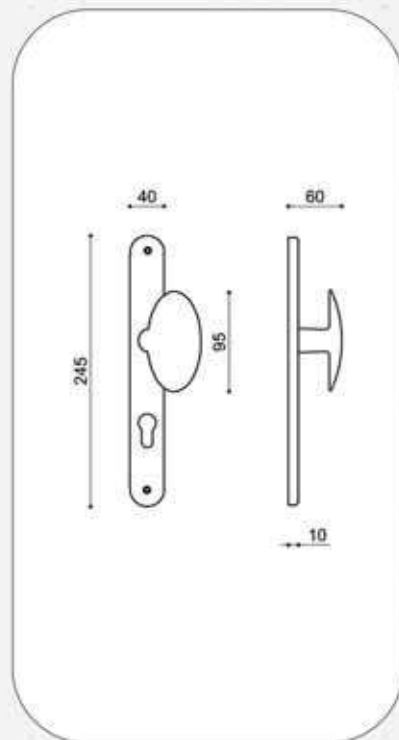

finiture:

- PVD ottone con trattamento PVD
- INOX ottone con trattamento PVD INOX

- OLV ottone lucido verniciato
- SV ottone satinato verniciato
- CS ottone cromato satinato
- CR ottone cromato lucido
- ANT ottone bronzato antico
- ORO ottone oro antico
- ARG ottone argento antico
- BG ottone bronzato graffiato

Maniglione accoppiato

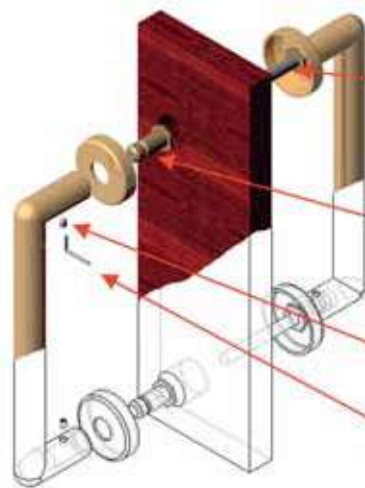

COMPONENTI PER IL MONTAGGIO:



TRONCONE



BUSSOLA CON DADO



GRANO



CHIAVETTA

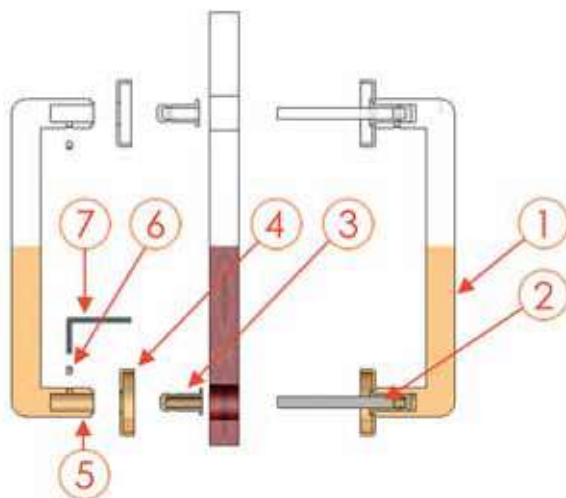

Sezione del montaggio dei maniglioni accoppiati.

MONTAGGIO:

Eeguire due fori passanti attraverso l'infisso, di distanza pari all'interasse del maniglione. Avvitare i tronconi (2) nel maniglione con le rosette già montate (1) e accostarlo all'infisso. avvitare sull'altro lato dell'infisso le bussole con dado (3) ed inserire le rosette (4). Ora infilare il maniglione senza le rosette montate (5) e fissarlo con gli appositi grani (6) e chiavetta (7).

Su richiesta disponibile anche il kit per il fissaggio della coppia su vetro

Maniglioni con rosette strette









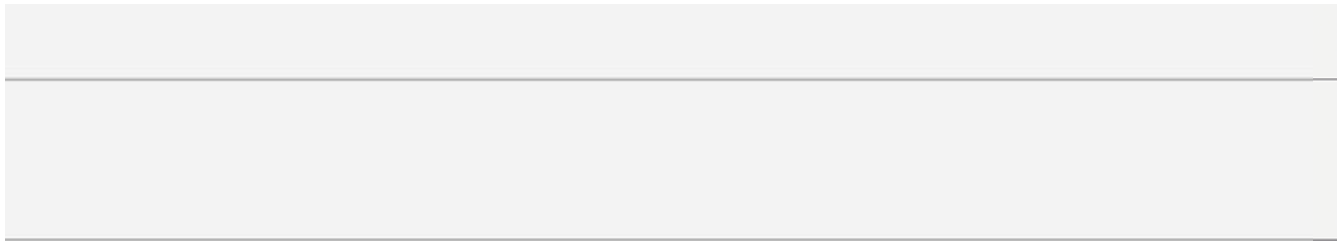









Caratteristica importante della gamma maniglioni è quella di poter variare il montaggio. Infatti su richiesta alcuni maniglioni hanno la possibilità di essere forniti con: rosetta ovale per i maniglioni tondeggianti, rosetta rettangolare per i maniglioni quadri. Questa variante viene utilizzata nelle situazioni di montaggio in cui i portoncini o le porte adottano uno spessore di battuta ridotto rispetto agli standard abituali.

La rosetta ovale ha una larghezza di 30 mm mentre la rettangolare di 32 mm





Maniglioni alzanti per scorrevoli

	2001 Spigola <i>pag. 178</i>		2005B Royal Junior B <i>pag. 185</i>
	2001B Spigola B <i>pag. 179</i>		2000R Royal R <i>pag. 186</i>
	2006 Spigola corto <i>pag. 180</i>		2000Z Royal Z <i>pag. 187</i>
	2006B Spigola corto B <i>pag. 181</i>		2004 Coppia speciale <i>pag. 188</i>
	2000 Royal <i>pag. 182</i>		2002 Placca Royal <i>pag. 189</i>
	2000B Royal B <i>pag. 183</i>		2003 Nicchia Royal <i>pag. 189</i>
	2005 Royal Junior <i>pag. 184</i>		2002Z Placca Royal Z <i>pag. 190</i>
			2003Z Nicchia Royal Z <i>pag. 190</i>
			2007 Placca quadra <i>pag. 191</i>
			2008 Nicchia quadra <i>pag. 191</i>

2001 Spigola

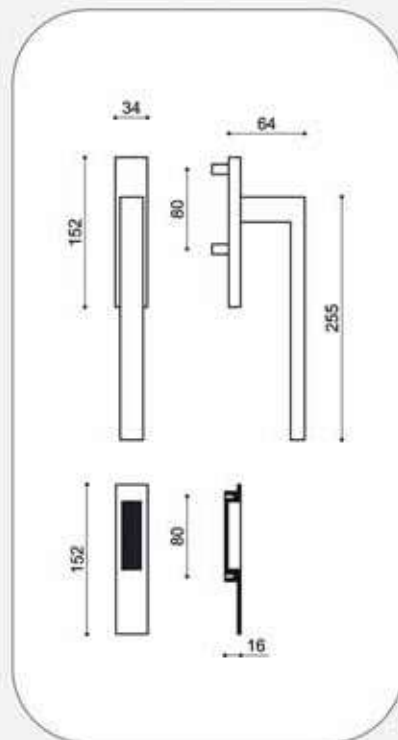

codici varianti:

modello standard: 2001

modello con foro yale: 2001Y

maniglione accoppiato:

modello accoppiato cieco: 2001C

modello accoppiato foro yale: 2001CY

finiture:

MCS

MCR

MNO

MBIA

maritech cromato satinato

maritech cromato lucido

maritech verniciato nero opaco

maritech verniciato bianco

2001B Spigola B

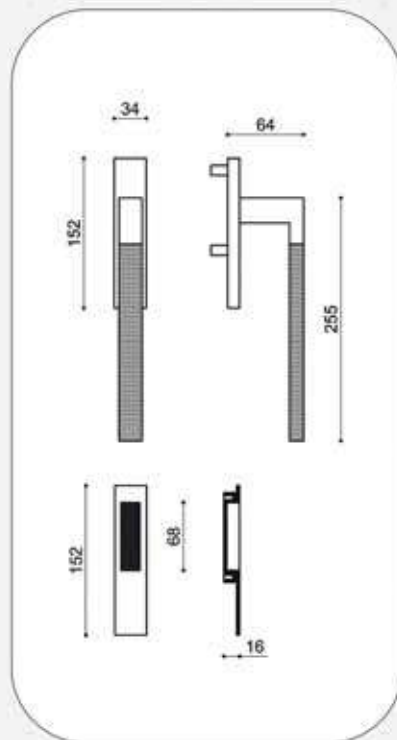

codici varianti:
modello standard: 2001B
modello con foro yale: 2001BY

maniglione accoppiato:
modello accoppiato cieco: 2001BC
modello accoppiato foro yale: 2001BCY

finiture:
MCR/CS maritech bicolore cromo/sat.

2006 Spigola corto

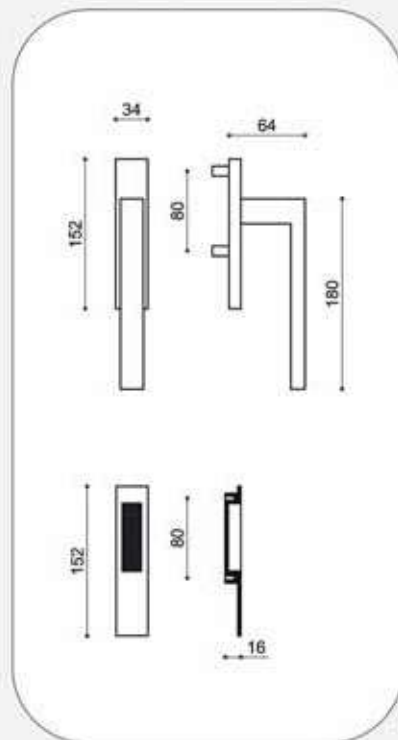

codici varianti:
modello standard: 2006
modello con foro yale: 2006Y

maniglione accoppiato:
modello accoppiato cieco: 2006C
modello accoppiato foro yale: 2006CY

finiture:
MCS maritech cromato satinato
MCR maritech cromato lucido
MNO maritech verniciato nero opaco
MBIA maritech verniciato bianco

2006B

Spigola corto B

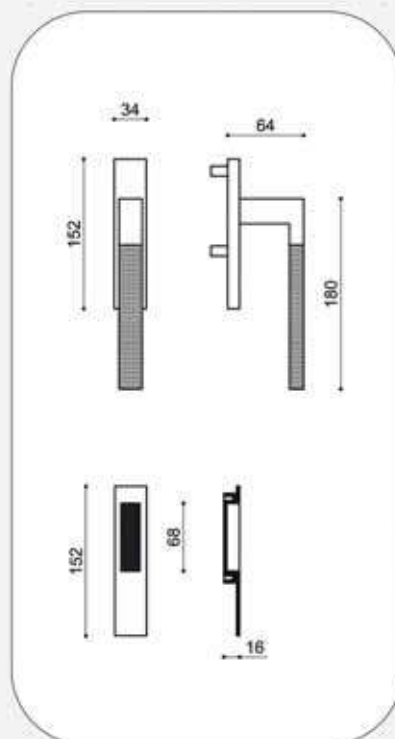

codici varianti:
modello standard: 2006B
modello con foro yale: 2006BY

maniglione accoppiato:
modello accoppiato cieco: 2006BC
modello accoppiato foro yale: 2006BCY

finiture:
MCR/CS maritech bicolore cromo/sat.

2000 Royal

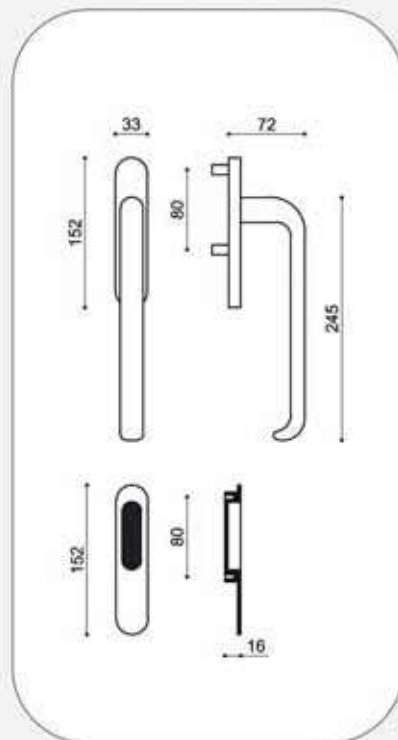

codici varianti:
 modello standard: 2000
 modello con foro yale: 2000Y

maniglione accoppiato:
 modello accoppiato cieco: 2000C
 modello accoppiato foro yale: 2000CY

finiture:
 PVD ottone con trattamento PVD
 INOX ottone con trattamento PVD INOX

OLV ottone lucido verniciato
 SV ottone satinato verniciato
 NKS ottone nikel satinato
 CS ottone cromato satinato
 CR ottone cromato lucido
 ANT ottone bronzo antico
 ORO ottone oro antico
 ARG ottone argento antico
 RAM ottone ramato antico
 BG ottone bronzato graffiato
 BV ottone bronzo verniciato
 BU ottone bronzo uniforme
 NL ottone verniciato nero lucido
 NO ottone verniciato nero opaco
 BIA ottone verniciato bianco

2000B

Royal B

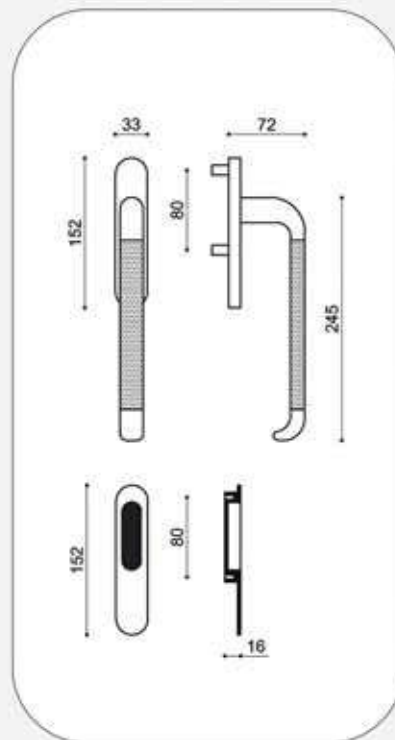

codici varianti:

modello standard: 2000B

modello con foro yale: 2000BY

maniglione accoppiato:

modello accoppiato cieco: 2000BC

modello accoppiato foro yale: 2000BCY

finiture:

PVD/SAT ottone bicolore PVD/SAT

OLV/OLS ottone bicolore lucido/satinato
CR/CS ottone bicolore cromo/satinato

2005 Royal Junior

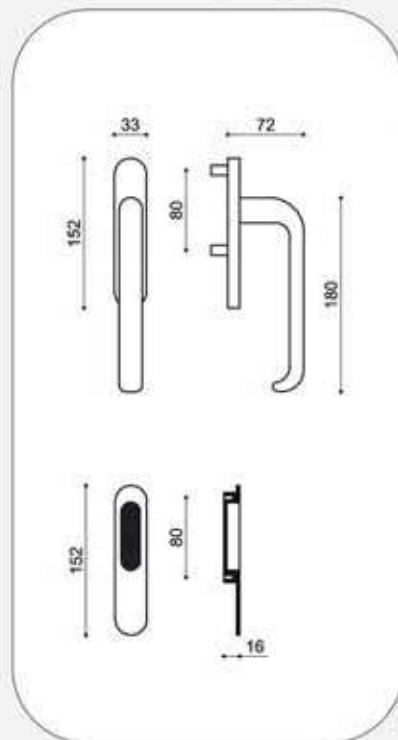

codici varianti:
 modello standard: 2005
 modello con foro yale: 2005Y

maniglione accoppiato:
 modello accoppiato cieco: 2005C
 modello accoppiato foro yale: 2005CY

finiture:
 PVD ottone con trattamento PVD
 INOX ottone con trattamento PVD INOX

OLV ottone lucido verniciato
 SV ottone satinato verniciato
 NKS ottone nickel satinato
 CS ottone cromato satinato
 CR ottone cromato lucido
 ANT ottone bronzo antico
 ORO ottone oro antico
 ARG ottone argento antico
 RAM ottone ramato antico
 BG ottone bronzato graffiato
 BV ottone bronzo verniciato
 BU ottone bronzo uniforme
 NL ottone verniciato nero lucido
 NO ottone verniciato nero opaco
 BIA ottone verniciato bianco

2005B Royal Junior B

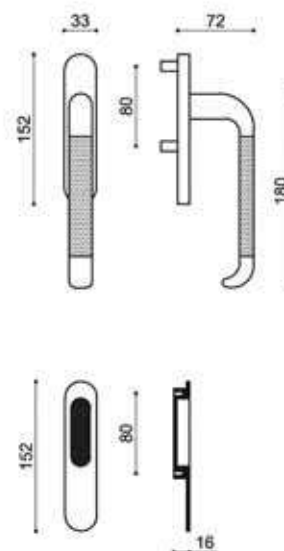

codici varianti:

modello standard: 2005B

modello con foro yale: 2005BY

maniglione accoppiato:

modello accoppiato cieco: 2005BC

modello accoppiato foro yale: 2005BCY

finiture:

PVD/SAT ottone bicolore PVD/SAT

OLV/OLS ottone bicolore lucido/satinato
CR/CS ottone bicolore cromo/satinato

2000R Royal R

Ⓑ

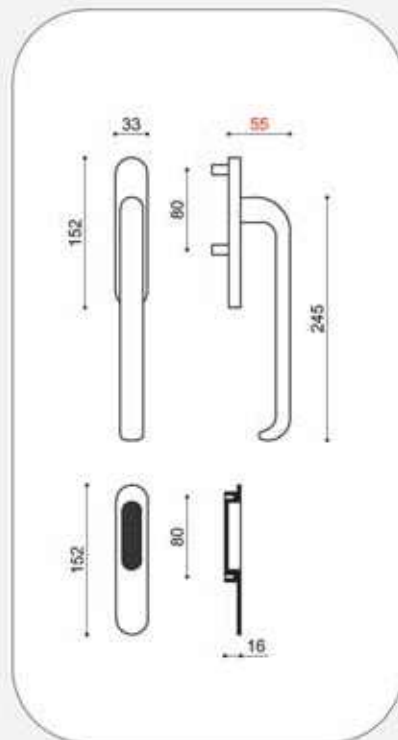

codici varianti:
modello standard: 2000R
modello con foro yale: 2000RY

maniglione accoppiato:
modello accoppiato cieco: 2000RC
modello accoppiato foro yale: 2000RCY

VERSIONE RIBASSATA

finiture:
OLV ottone lucido verniciato
CS ottone cromato satinato

2000Z

Royal Z

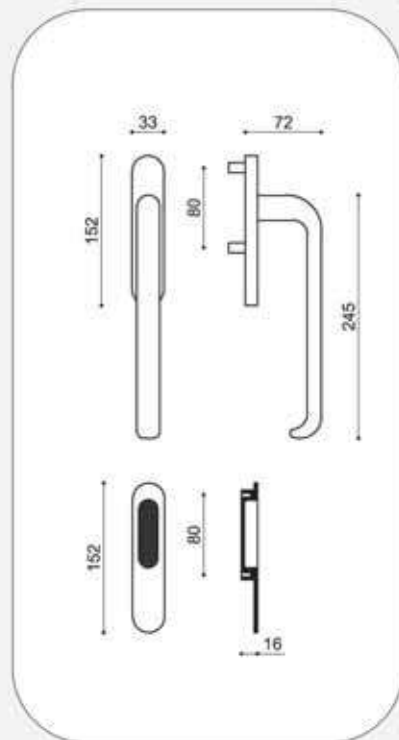

codici varianti:
modello standard: 2000Z
modello con foro yale: 2000ZY

maniglione accoppiato:
modello accoppiato cieco: 2000ZC
modello accoppiato foro yale: 2000ZCY

finiture:
MPVD maritech con trattamento PVD
MORO maritech oro lucido
MCS maritech cromato satinato

2004 Royal Coppia speciale

Ⓑ

Maniglione ribassato

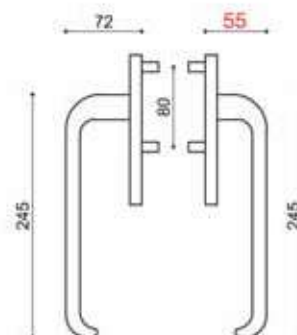

versioni:
modello accoppiato cieco: 2008CS
modello accoppiato foro yale: 2008CSY

**VERSIONE COPPIA SPECIALE
CON UN MANIGLIONE
ART. 2000 NORMALE E UNO
ART. 2000R RIBASSATO**

finiture:
OLV ottone lucido verniciato
CS ottone cromato satinato

2002 Placca Royal

pvd B

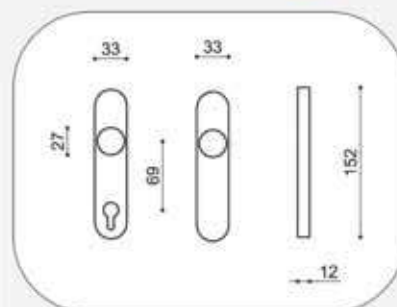

codici varianti:
 modello senza foro: 2002
 modello con foro yale: 2002Y

finiture:
 PVD ottone con trattamento PVD
 INOX ottone con trattamento PVD INOX

OLV ottone lucido verniciato
 SV ottone satinato verniciato
 NKS ottone nikel satinato
 CS ottone cromato satinato
 CR ottone cromato lucido
 ANT ottone bronzo antico
 ORO ottone oro antico
 ARG ottone argento antico
 RAM ottone ramato antico
 BG ottone bronzato graffiato
 BV ottone bronzo verniciato
 BU ottone bronzo uniforme
 NL ottone verniciato nero lucido
 NO ottone verniciato nero opaco
 BIA ottone verniciato bianco

2003 Nicchia Royal

pvd B

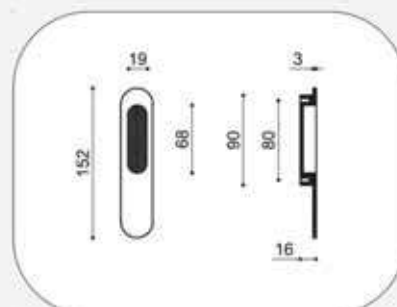

finiture:
 PVD ottone con trattamento PVD
 INOX ottone con trattamento PVD INOX

OLV ottone lucido verniciato
 SV ottone satinato verniciato
 NKS ottone nikel satinato
 CS ottone cromato satinato
 CR ottone cromato lucido
 ANT ottone bronzo antico
 ORO ottone oro antico
 ARG ottone argento antico
 RAM ottone ramato antico
 BG ottone bronzato graffiato
 BV ottone bronzo verniciato
 BU ottone bronzo uniforme
 NL ottone verniciato nero lucido
 NO ottone verniciato nero opaco
 BIA ottone verniciato bianco

2002Z Placca Royal Z

5

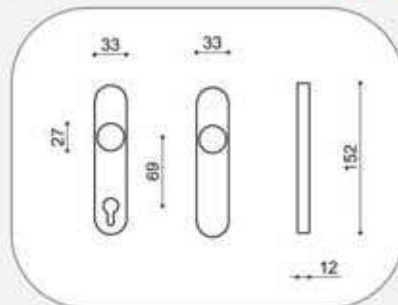

codici varianti:
modello senza foro: 2002Z
modello con foro yale: 2002ZY

finiture:
MORO maritech oro lucido
MCS maritech cromato satinato
MNO maritech verniciato nero opaco
MBIA maritech verniciato bianco

2003Z Nicchia Royal Z

5

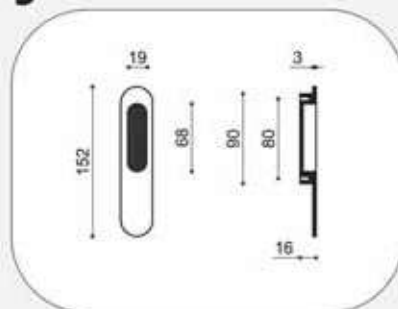

finiture:
MORO maritech oro lucido
MCS maritech cromato satinato
MNO maritech verniciato nero opaco
MBIA maritech verniciato bianco

2007 Placca Quadra

3

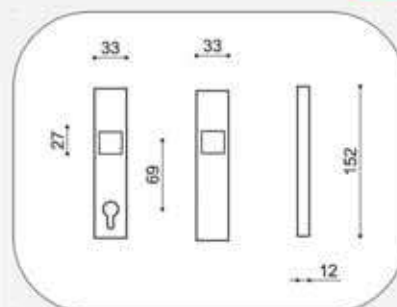

codici varianti:
modello senza foro: 2007
modello con foro yale: 2007Y

finiture:
MCS maritech cromato satinato
MCR maritech cromato lucido

2008 Nicchia Quadra

3

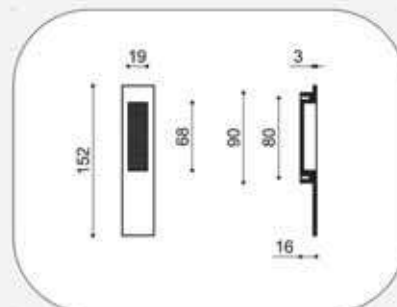

finiture:
MCS maritech cromato satinato
MCR maritech cromato lucido

Kit ferro quadro per maniglione alzante

kit ferro quadro e viti **Standard** su alzante singolo:

quadro 10x100 con angoli smussati per serratura L mm 65 ed angolo vivo per ingresso maniglione L mm 35
viti M5 lunghezza totale mm 95 seghettate con filettatura di 72 mm



kit ferro quadro e viti **Standard** su alzante accoppiato:

quadro 10x130 con angoli smussati per serratura
viti M5 lunghezza totale mm125 con filettatura di 23 mm
dadi M5 di fissaggio



extra:

kit ferro quadro e viti per alzante singolo a richiesta:

quadro 10x70 con angoli smussati per serratura
viti M5 lunghezza totale mm 75 con filettatura di 40 mm



vite speciale:

vite M5 lunghezza totale mm 125 con filettatura di 23 mm



Varianti maniglione alzante



MANIGLIONE ALZANTE STANDARD:

- COMPONENTI:
- n° 1 maniglione alzante
 - n° 1 movimento
 - n° 1 ferro quadro
 - n° 2 viti passanti
 - n° 1 placca coprimovimento
 - n° 1 nicchia

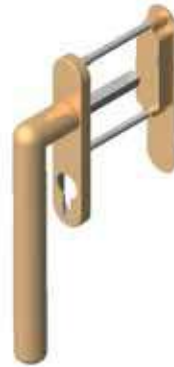

MANIGLIONE ALZANTE CON FORO YALE:

- COMPONENTI:
- n° 1 maniglione alzante
 - n° 1 movimento
 - n° 1 ferro quadro
 - n° 2 viti passanti
 - n° 1 placca coprimovimento con foro yale
 - n° 1 nicchia

LETTERA
VARIANTE: Y



MANIGLIONE ALZANTE SINGOLO:

- COMPONENTI:
- n° 1 maniglione alzante
 - n° 1 movimento
 - n° 1 ferro quadro
 - n° 2 viti passanti
 - n° 1 placca coprimovimento

LETTERA
VARIANTE: S



MANIGLIONE ALZANTE SINGOLO CON FORO YALE:

- COMPONENTI:
- n° 1 maniglione alzante
 - n° 1 movimento
 - n° 1 ferro quadro
 - n° 2 viti passanti
 - n° 1 placca coprimovimento con foro yale

LETTERA
VARIANTE: SY



MANIGLIONE ALZANTE ACCOPPIATO:

- COMPONENTI:
- n° 2 maniglioni alzante
 - n° 2 movimenti
 - n° 1 ferro quadro
 - n° 2 viti passanti
 - n° 2 placca coprimovimento

LETTERA
VARIANTE: C



MANIGLIONE ALZANTE ACCOPPIATO CON FORO YALE:

- COMPONENTI:
- n° 2 maniglioni alzante
 - n° 2 movimenti
 - n° 1 ferro quadro
 - n° 2 viti passanti
 - n° 2 placca coprimovimento con foro yale

LETTERA
VARIANTE: CY



Pomoli fissi

 126 Spigola <i>pag. 196</i>	 144 Special <i>pag. 201</i>
 127 Spigola small <i>pag. 196</i>	 149 Urano <i>pag. 201</i>
 136 Square <i>pag. 197</i>	 153 Smart <i>pag. 202</i>
 137 Cubo <i>pag. 197</i>	 155 Lux <i>pag. 202</i>
 138 Spirit <i>pag. 198</i>	 156 Ovotto <i>pag. 203</i>
 139 Lunik <i>pag. 198</i>	 157 Zaffiro <i>pag. 203</i>
 141 Sfera <i>pag. 199</i>	 158 Smeraldo <i>pag. 204</i>
 142 Cipolla <i>pag. 199</i>	 159 Cristal <i>pag. 204</i>
 143 65 Ideal 65 <i>pag. 200</i>	 159 RS Cristal RS <i>pag. 205</i>
 143 75 Idela 75 <i>pag. 200</i>	 167 Margherita <i>pag. 205</i>

126 Spigola

Ⓑ

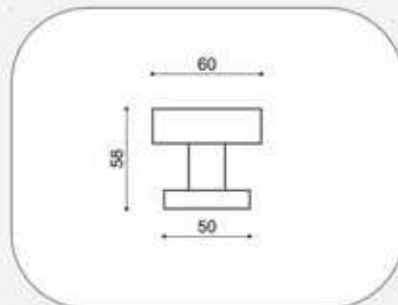

rosetta standard:
RQ50 rosetta quadra mm 50x50
varianti:
RR rosetta rettangolare

finiture:
CS ottone cromato satinato
CR ottone cromato lucido

127 Spigola small

Ⓑ

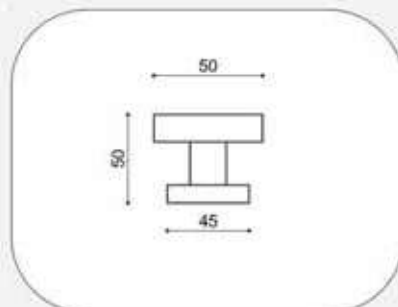

rosetta standard:
RQ45 rosetta quadra mm 45x45
varianti:
RR rosetta rettangolare

finiture:
CS ottone cromato satinato
CR ottone cromato lucido

136 Square

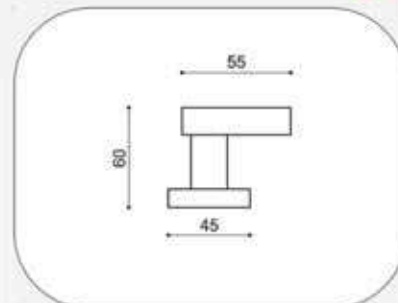

rosetta standard:
RQ45 rosetta quadra mm 45x45
varianti:
RR rosetta rettangolare

finiture:
MCS maritech cromato satinato
MCS maritech cromato lucido
MCR/CS maritech bi colore cromo/sat.

137 Cubo

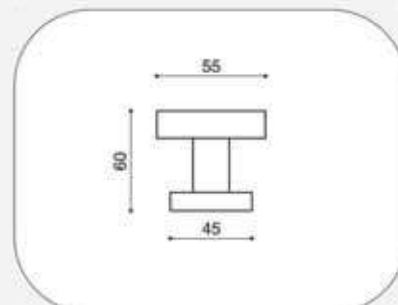

rosetta standard:
RQ45 rosetta quadra mm 45x45
varianti:
RR rosetta rettangolare

finiture:
MCS maritech cromato satinato
MCS maritech cromato lucido
MCR/CS maritech bi colore cromo/sat.

138 Spirit

pvd B

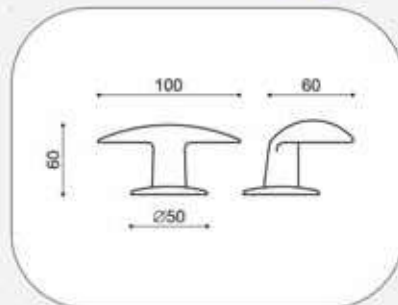

rosetta standard:
rosetta tonda d. 50 mm
varianti:
RO rosetta ovale

finiture:

PVD ottone con trattamento PVD
INOX ottone con trattamento PVD INOX

OLV ottone lucido verniciato
SV ottone satinato verniciato
CS ottone cromato satinato
CR ottone cromato lucido
ANT ottone bronzo antico
ORO ottone oro antico
ARG ottone argento antico
RAM ottone ramato antico
BG ottone bronzato graffiato

139 Lunik

pvd B

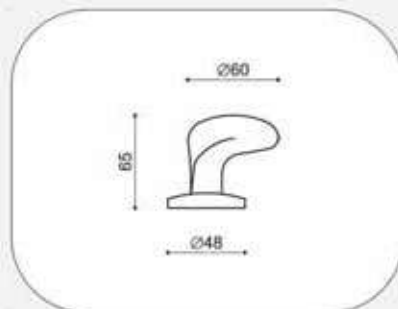

rosetta standard:
RB rosetta bombata d. 48 mm
varianti:
RO rosetta ovale

finiture:

PVD ottone con trattamento PVD
INOX ottone con trattamento PVD INOX

OLV ottone lucido verniciato
SV ottone satinato verniciato
CS ottone cromato satinato
CR ottone cromato lucido
BG ottone bronzato graffiato

141 Sfera

pvd B

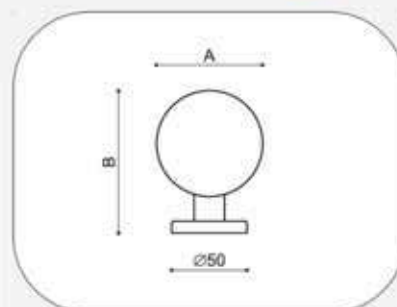

rosetta standard:
rosetta tonda d. 50 mm

varianti:
RO rosetta ovale

versioni:
art. 141 50 diametro A: 50 mm B: 75 mm
art. 141 60 diametro A: 60 mm B: 80 mm
art. 141 70 diametro A: 70 mm B: 90 mm
art. 141 80 diametro A: 80 mm B: 100 mm

finiture:
PVD ottone con trattamento PVD
INOX ottone con trattamento PVD INOX

OLV ottone lucido verniciato
SV ottone satinato verniciato
CS ottone cromato satinato
CR ottone cromato lucido
BG ottone bronzato graffiato

142 Cipolla

pvd B

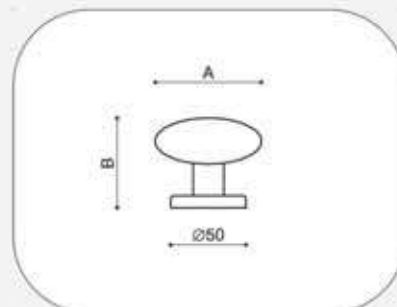

rosetta standard:
rosetta tonda d. 50 mm

varianti:
RO rosetta ovale
R80 rosone d. 80 mm

versioni:
art. 142 60 diametro A: 60 mm B: 60 mm
art. 142 70 diametro A: 70 mm B: 65 mm

finiture:
PVD ottone con trattamento PVD
INOX ottone con trattamento PVD INOX

OLV ottone lucido verniciato
SV ottone satinato verniciato
CS ottone cromato satinato
CR ottone cromato lucido
BG ottone bronzato graffiato

143₆₅ Ideal d.65

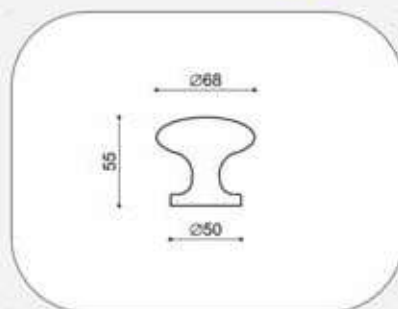

rosetta standard:
rosetta incorporata d. 50 mm

- finiture:**
- PVD ottone con trattamento PVD
 - INOX ottone con trattamento PVD INOX
 - OLV ottone lucido verniciato
 - SV ottone satinato verniciato
 - CS ottone cromato satinato
 - CR ottone cromato lucido
 - ANT ottone bronzo antico
 - ORO ottone oro antico
 - ARG ottone argento antico
 - RAM ottone ramato antico
 - BG ottone bronzato graffiato
 - BU ottone bronzato uniforme

143₇₅ Ideal d.75

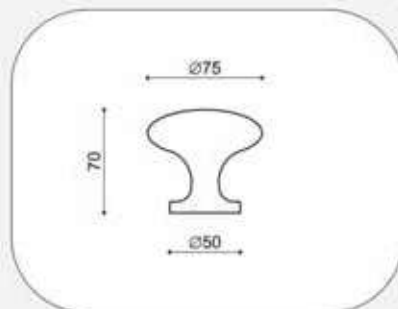

rosetta standard:
rosetta incorporata d. 50 mm

- finiture:**
- PVD ottone con trattamento PVD
 - INOX ottone con trattamento PVD INOX
 - OLV ottone lucido verniciato
 - SV ottone satinato verniciato
 - CS ottone cromato satinato
 - CR ottone cromato lucido
 - ANT ottone bronzo antico
 - ORO ottone oro antico
 - ARG ottone argento antico
 - RAM ottone ramato antico
 - BG ottone bronzato graffiato
 - BU ottone bronzato uniforme

144 Special

pvd B

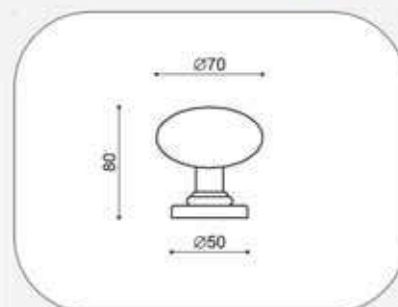

rosetta standard:
rosetta tonda d. 50 mm

finiture:
PVD ottone con trattamento PVD
INOX ottone con trattamento PVD INOX

OLV ottone lucido verniciato
SV ottone satinato verniciato
CS ottone cromato satinato
CR ottone cromato lucido
BG ottone bronzato graffiato

149 Urano

B

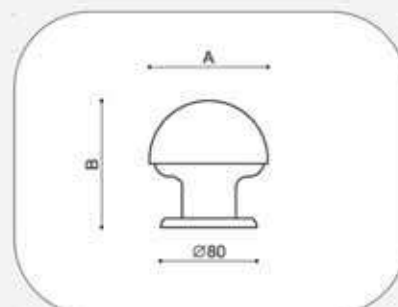

rosetta standard:
rosetta tonda d. 80 mm

versioni:
art. 149 60 diametro A: 60 mm B: 60 mm
art. 149 70 diametro A: 70 mm B: 70 mm
art. 149 80 diametro A: 80 mm B: 80 mm

finiture:
OLV ottone lucido verniciato
CS ottone cromato satinato
BG ottone bronzato graffiato

153 Smart

ⓑ

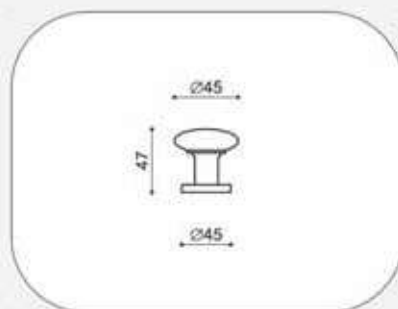

rosetta standard:
rosetta tonda d. 45 mm
varianti:
RO rosetta ovale

finiture:
OLV ottone lucido verniciato
CS ottone cromato satinato
CR ottone cromato lucido
BG ottone bronzato graffiato

155 Lux

pvd ⓑ

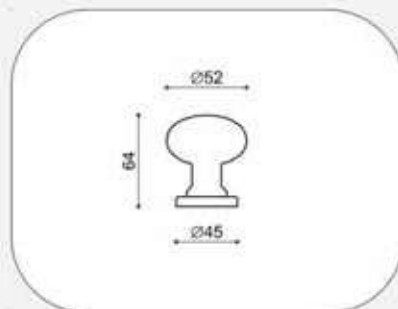

rosetta standard:
rosetta tonda d. 45 mm
varianti:
RO rosetta ovale

finiture:
PVD ottone con trattamento PVD
OLV ottone lucido verniciato
SV ottone satinato verniciato
CS ottone cromato satinato
CR ottone cromato lucido
ANT ottone bronzo antico
ORO ottone oro antico
ARG ottone argento antico
RAM ottone ramato antico
BG ottone bronzato graffiato

156 Ovotto

ⓑ

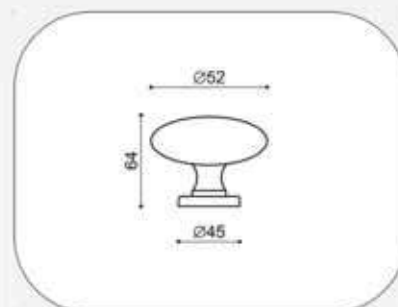

rosetta standard:
rosetta tonda d. 45 mm
varianti:
RO rosetta ovale

finiture:
OLV ottone lucido verniciato
CS ottone cromato satinato
CR ottone cromato lucido
BG ottone bronzato graffiato

157 Zaffiro

pvd ⓑ



rosetta standard:
rosetta incorporata d. 50 mm
versioni:
art. 157 65 diametro A: 68 mm B: 55 mm
art. 157 75 diametro A: 75 mm B: 70 mm

finiture:
PVD ottone con trattamento PVD
PVD/SAT ottone bi colore con tratt. PVD/SAT

OLV ottone lucido verniciato
OLV/OLS ottone bi colore lucido/satinato
CS ottone cromato satinato
CR ottone cromato lucido
CR/CS ottone bi colore cromo/satinato
BG ottone bronzato graffiato

158 Smeraldo

pvd B



rosetta standard:
rosetta incorporata d. 50 mm
versioni:
art. 158 65 diametro A: 68 mm B: 55 mm
art. 158 75 diametro A: 75 mm B: 70 mm

finiture:
PVD ottone con trattamento PVD
OLV ottone lucido verniciato
CS ottone cromato satinato
CR ottone cromato lucido

159 Cristal

pvd B



rosetta standard:
rosetta tonda d. 50 mm

finiture:
PVD ottone con trattamento PVD
OLV ottone lucido verniciato
SV ottone satinato verniciato
CS ottone cromato satinato
CR ottone cromato lucido
ANT ottone bronzo antico
ORO ottone oro antico
ARG ottone argento antico
RAM ottone ramato antico
BG ottone bronzato graffiato

159^{RS} Cristal RS

pvd B

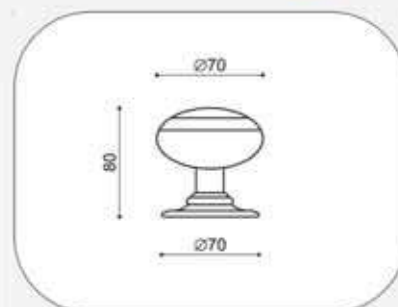

rosetta standard:
rosetta sagomata d. 70 mm

finiture:

PVD ottone con trattamento PVD

- OLV ottone lucido verniciato
- CS ottone cromato satinato
- CR ottone cromato lucido
- ANT ottone bronzo antico
- ORO ottone oro antico
- ARG ottone argento antico
- RAM ottone ramato antico

167 Margherita

pvd B

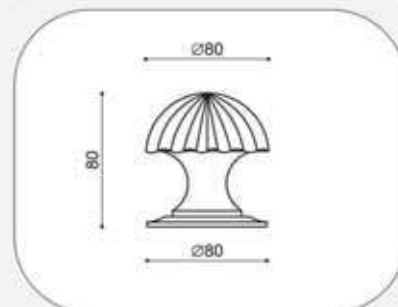

rosetta standard:
rosetta sagomata d. 80 mm

finiture:

PVD ottone con trattamento PVD

- OLV ottone lucido verniciato
- CS ottone cromato satinato
- CR ottone cromato lucido
- ANT ottone bronzo antico
- ORO ottone oro antico
- ARG ottone argento antico
- RAM ottone ramato antico
- BG ottone bronzato graffiato

Pomoli a coppia



136C
coppia Square
pag. 209



137C
coppia Cubo
pag. 209



139C
coppia Lunik
pag. 210



141C
coppia Sfera
pag. 210



142C
coppia Cipolla
pag. 211



153C
coppia Smart
pag. 211



155C
coppia Lux
pag. 212



156C
coppia Ovotto
pag. 212



126C
coppia Spigola
pag. 208



1260C
coppia Uovo
pag. 213



127C
coppia Spigola
small
pag. 208



2260C
coppia Sirio
pag. 213

126C coppia Spigola

Ⓑ



coppia girevole con molla o senza molla

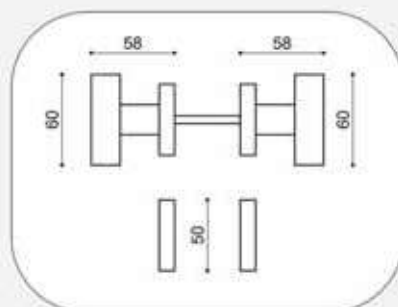

rosetta standard:
RQ50 rosetta quadra mm 50x50
varianti:
RR rosetta rettangolare

finiture:
CS ottone cromato satinato
CR ottone cromato lucido

127C coppia Spigola small

Ⓑ



coppia girevole con molla o senza molla

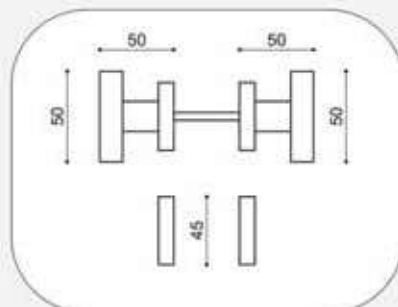

rosetta standard:
RQ45 rosetta quadra mm 45x45
varianti:
RR rosetta rettangolare

finiture:
CS ottone cromato satinato
CR ottone cromato lucido

136C coppia Square



coppia girevole con molla o senza molla

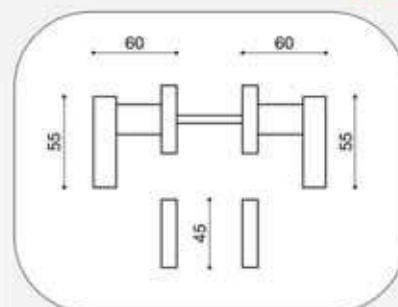

rosetta standard:
RQ45 rosetta quadra mm 45x45
varianti:
RR rosetta rettangolare

finiture:
MCS maritech cromato satinato
MCS maritech cromato lucido
MCR/CS maritech bi colore cromo/sat.

137C coppia Cubo



coppia girevole con molla o senza molla

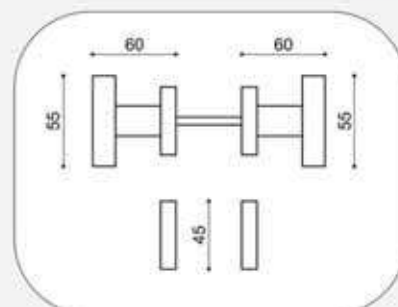

rosetta standard:
RQ45 rosetta quadra mm 45x45
varianti:
RR rosetta rettangolare

finiture:
MCS maritech cromato satinato
MCS maritech cromato lucido
MCR/CS maritech bi colore cromo/sat.

139C coppia Lunik



coppia girevole con molla o senza molla

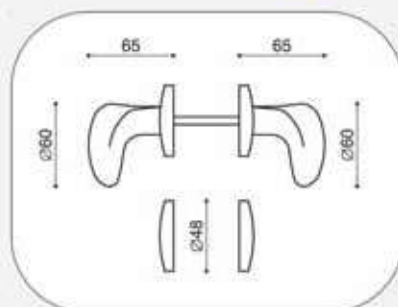

rosetta standard:
 RB rosetta bombata d. 48 mm
varianti:
 RO rosetta ovale

finiture:
 PVD ottone con trattamento PVD
 INOX ottone con trattamento PVD INOX

OLV ottone lucido verniciato
 SV ottone satinato verniciato
 CS ottone cromato satinato
 CR ottone cromato lucido
 BG ottone bronzato graffiato

141C coppia Sfera



coppia girevole con molla o senza molla

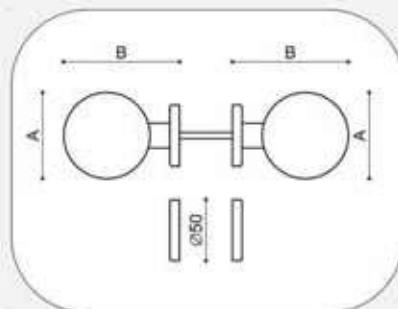

rosetta standard:
 rosetta tonda d. 50 mm
varianti:
 RO rosetta ovale
versioni:
 art. 141C 50 diametro A: 50 mm B: 75 mm
 art. 141C 60 diametro A: 60 mm B: 80 mm
 art. 141C 70 diametro A: 70 mm B: 90 mm

finiture:
 PVD ottone con trattamento PVD

OLV ottone lucido verniciato
 CS ottone cromato satinato
 CR ottone cromato lucido
 BG ottone bronzato graffiato

142C coppia Cipolla

(pvd) (B)



coppia girevole con molla o senza molla

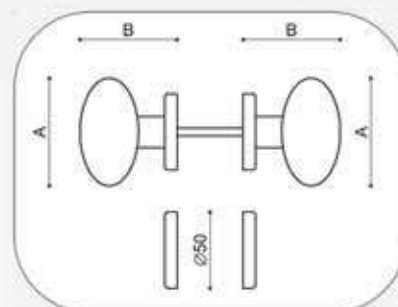

rosetta standard:

rosetta tonda d. 50 mm

varianti:

RO rosetta ovale

versioni:

art. 142C 60 diametro A: 60 mm B: 60 mm

art. 142C 70 diametro A: 70 mm B: 65 mm

finiture:

PVD ottone con trattamento PVD

- OLV ottone lucido verniciato
- SV ottone satinato verniciato
- CS ottone cromato satinato
- CR ottone cromato lucido
- BG ottone bronzato graffiato

153C coppia Smart

(B)



coppia girevole con molla o senza molla

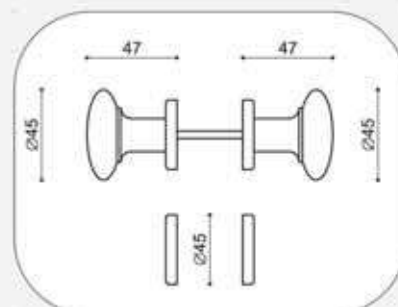

rosetta standard:

rosetta tonda d. 45 mm

varianti:

RO rosetta ovale

finiture:

- OLV ottone lucido verniciato
- CS ottone cromato satinato
- CR ottone cromato lucido
- BG ottone bronzato graffiato

155C coppia Lux

pvd (B)



coppia girevole con molla o senza molla

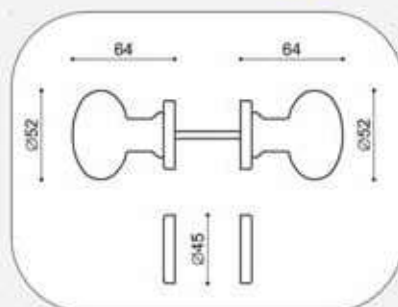

rosetta standard:
rosetta tonda d. 45 mm
varianti:
RO rosetta ovale

finiture:

- PVD ottone con trattamento PVD
- OLV ottone lucido verniciato
- SV ottone satinato verniciato
- CS ottone cromato satinato
- CR ottone cromato lucido
- ANT ottone bronzo antico
- ORO ottone oro antico
- ARG ottone argento antico
- RAM ottone ramato antico
- BG ottone bronzato graffiato

156C coppia Ovotto

(B)



coppia girevole con molla o senza molla

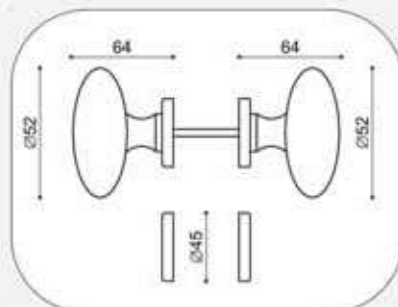

rosetta standard:
rosetta tonda d. 45 mm
varianti:
RO rosetta ovale

finiture:

- OLV ottone lucido verniciato
- CS ottone cromato satinato
- CR ottone cromato lucido
- BG ottone bronzato graffiato

1260C coppia Uovo

pvd B



coppia girevole con molla o senza molla

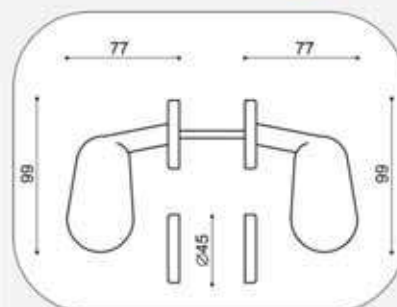

rosetta standard:
rosetta tonda d. 45 mm
varianti:
RB rosetta bombata d. 48 mm
RO rosetta ovale

finiture:
PVD ottone con trattamento PVD
OLV ottone lucido verniciato
SV ottone satinato verniciato
CS ottone cromato satinato
CR ottone cromato lucido
ANT ottone bronzo antico
BG ottone bronzato graffiato

2260C coppia Sirio

pvd B



coppia girevole con molla o senza molla

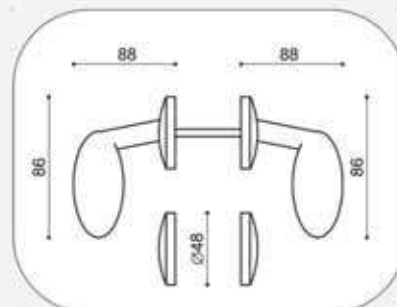

rosetta standard:
rosetta bombata d. 48 mm
varianti:
RO rosetta ovale

finiture:
PVD ottone con trattamento PVD
OLV ottone lucido verniciato
SV ottone satinato verniciato
CS ottone cromato satinato
CR ottone cromato lucido
ANT ottone bronzo antico
ORO ottone oro antico
ARG ottone argento antico
BG ottone bronzato graffiato

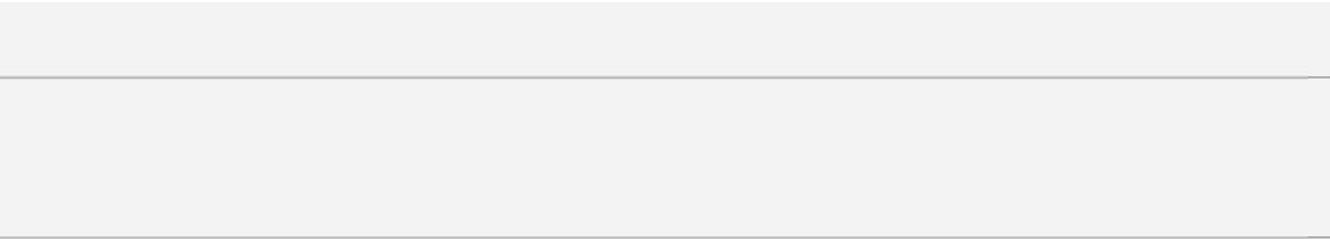



Battenti



120
Seven
pag. 216



125
Anello
pag. 216



130
Margherita
pag. 217



135
Barocco
pag. 217



140
Classic
pag. 218



145
Lion
pag. 218

120 Seven

pvd (B)

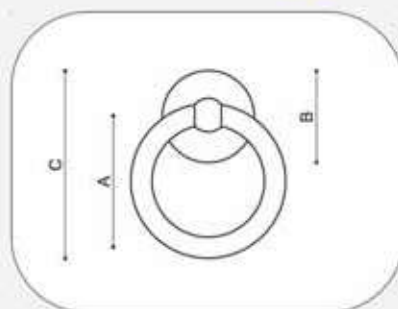

A: 110 mm
B: 80 mm
C: 170 mm

finiture:

PVD ottone con trattamento PVD

OLV ottone lucido verniciato

CS ottone cromato satinato

CR ottone cromato lucido

ANT ottone bronzo antico

ORO ottone oro antico

ARG ottone argento antico

RAM ottone ramato antico

BG ottone bronzato graffiato

125 Anello

(B)

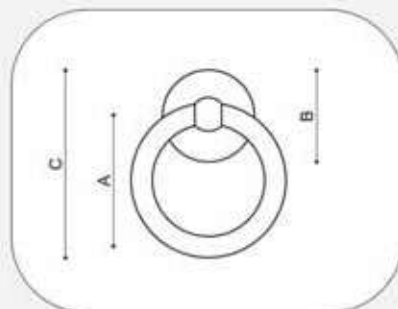

versioni:

art. 125 90 battente anello d. 90 mm
A: 80 mm B: 60 mm C: 115 mm

art. 125 110 battente anello d. 110 mm
A: 95 mm B: 80 mm C: 140 mm

art. 125 130 battente anello d. 130 mm
A: 115 mm B: 80 mm C: 160 mm

finiture:

OLV ottone lucido verniciato

CS ottone cromato satinato

CR ottone cromato lucido

130 Margherita

pvd (B)

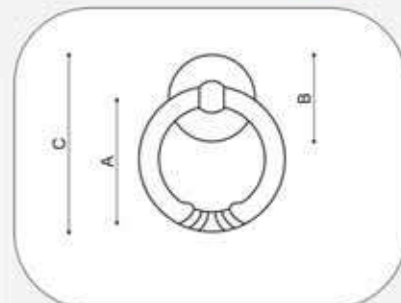

versioni:

art. 130 100 battente margherita d. 100 mm
A: 85 mm B: 60 mm C: 125 mm

art. 130 120 battente margherita d. 120 mm
A: 108 mm B: 80 mm C: 155 mm

finiture:

PVD ottone con trattamento PVD

OLV ottone lucido verniciato

CS ottone cromato satinato

CR ottone cromato lucido

ANT ottone bronzo antico

ORO ottone oro antico

ARG ottone argento antico

RAM ottone ramato antico

BG ottone bronzato graffiato

135 Barocco

(B)

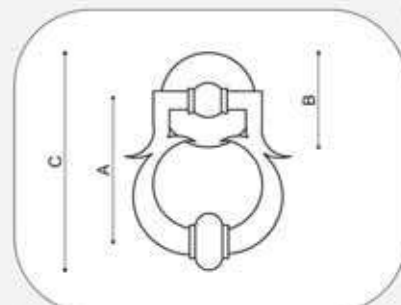

versioni:

art. 135 120 battente barocco d. 120 mm
A: 95 mm B: 80 mm C: 150 mm

art. 135 150 battente barocco d. 150 mm
A: 120 mm B: 80 mm C: 170 mm

art. 135 180 battente barocco d. 180 mm
A: 150 mm B: 105 mm C: 190 mm

finiture:

OLV ottone lucido verniciato

CS ottone cromato satinato

BS ottone bronzato sfumato

140 Classic

Ⓑ

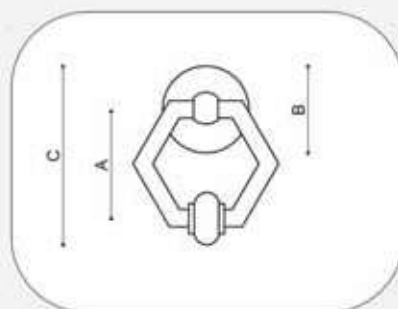

versioni:

art. 140 100 battente classic d. 100 mm
A: 75 mm B: 80 mm C: 125 mm

art. 140 120 battente classic d. 120 mm
A: 90 mm B: 80 mm C: 155 mm

finiture:

OLV ottone lucido verniciato
CS ottone cromato satinato
CR ottone cromato lucido

145 Lion

Ⓑ

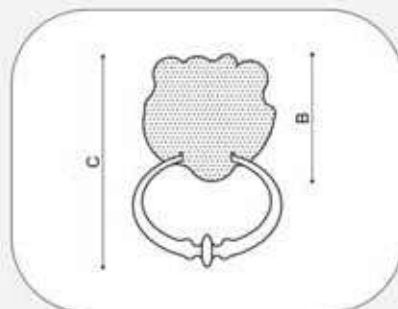

versioni:

art. 145 90 battente lion d. 90 mm
B: 90 mm C: 120 mm

art. 145 120 battente lion d. 120 mm
B: 120 mm C: 180 mm

finiture:

OLV ottone lucido verniciato
CS ottone cromato satinato
ANT ottone bronzo antico
ORO ottone oro antico
ARG ottone argento antico
BG ottone bronzato graffiato

Fissaggio battenti

fissaggio pasante

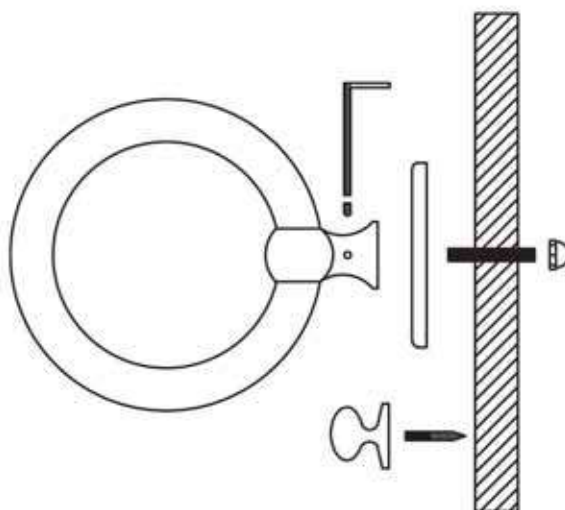

fissaggio con piastrino

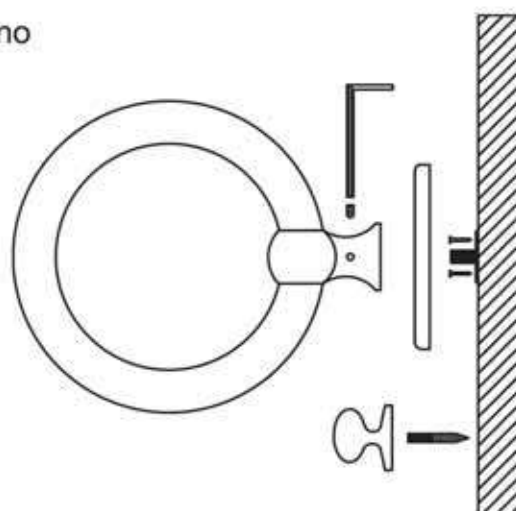



Sicurezza

 300 Bocchetta <i>pag. 222</i>	 1507 Placchetta <i>pag. 227</i>	 1522 Pomolo <i>pag. 232</i>
 301 Bocchetta <i>pag. 222</i>	 1508 Placchetta <i>pag. 227</i>	 1523 Pomolino <i>pag. 232</i>
 302 Placchetta <i>pag. 223</i>	 1509 Placchetta <i>pag. 228</i>	 1903 Quadro esp. <i>pag. 233</i>
 303 Placchetta <i>pag. 223</i>	 2510 Placchetta <i>pag. 228</i>	 1920 Quadro niples <i>pag. 233</i>
 304 Placchetta <i>pag. 224</i>	 1511 Placchetta <i>pag. 229</i>	 1200 Bocchetta tonda <i>pag. 234</i>
 1501 Bocchetta <i>pag. 224</i>	 156 Ovotto <i>pag. 229</i>	 1210 Bocchetta tonda <i>pag. 234</i>
 1502 Bocchetta <i>pag. 225</i>	 165 Olivetta <i>pag. 230</i>	 1230 Bocchetta tonda <i>pag. 235</i>
 1503 Bocchetta <i>pag. 225</i>	 153 Smart <i>pag. 230</i>	 1235 Bocchetta ovale <i>pag. 235</i>
 1505 Placchetta <i>pag. 226</i>	 155 Lux <i>pag. 231</i>	 H Porte Hotel <i>pag. 236</i>
 1506 Placchetta <i>pag. 226</i>	 1521 Pomolo <i>pag. 231</i>	 H Porte Hotel <i>pag. 237</i>

300 Bocchetta di sicurezza d. 50

pvd (B)

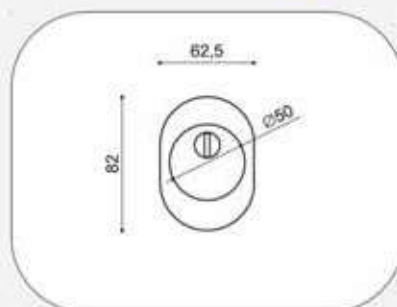

Bocchetta di sicurezza d. 50 mm con sottobocchetta in acciaio temprato antitrapano

finiture:

PVD ottone con trattamento PVD

OLV ottone lucido verniciato

CS ottone cromato satinato

CR ottone cromato lucido

BG ottone bronzato graffiato

301 Bocchetta di sicurezza d. 46

pvd (B)

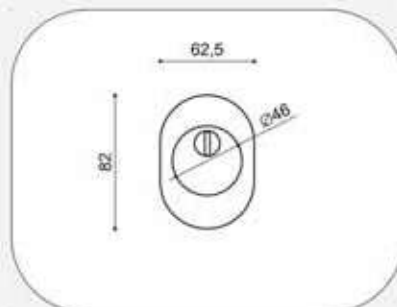

Bocchetta di sicurezza d. 50 mm con sottobocchetta in acciaio temprato antitrapano

finiture:

PVD ottone con trattamento PVD

OLV ottone lucido verniciato

CS ottone cromato satinato

CR ottone cromato lucido

BG ottone bronzato graffiato

302 Placchetta foro tondo

pvd B

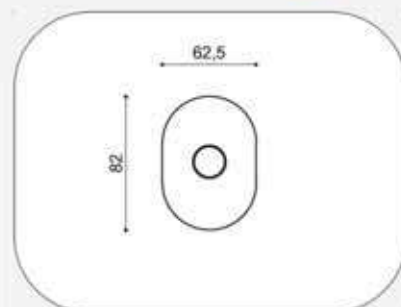

finiture:
PVD ottone con trattamento PVD
OLV ottone lucido verniciato
CS ottone cromato satinato
CR ottone cromato lucido
BG ottone bronzato graffiato

303 Placchetta foro yale

pvd B

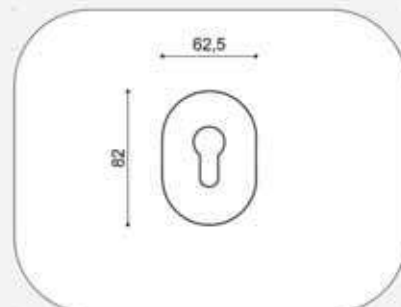

finiture:
PVD ottone con trattamento PVD
OLV ottone lucido verniciato
CS ottone cromato satinato
CR ottone cromato lucido
BG ottone bronzato graffiato

304 Placchetta per pom. limitatore

pvd (B)

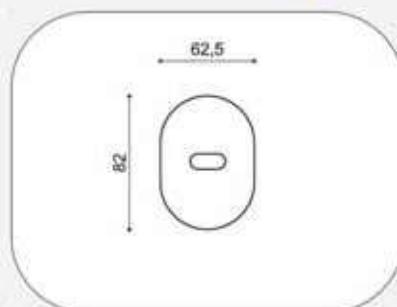

finiture:

PVD ottone con trattamento PVD

OLV ottone lucido verniciato

CS ottone cromato satinato

CR ottone cromato lucido

BG ottone bronzato graffiato

1501 Bocchetta a baionetta mm10

pvd (B)

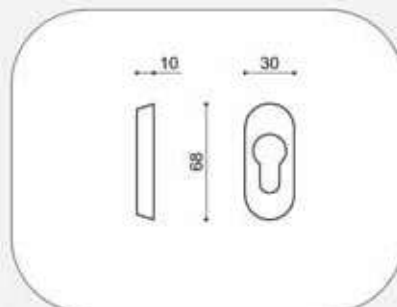

bocchetta di sicurezza ovale con foro yale e fori vite nascosti, montaggio a baionetta

finiture:

PVD ottone con trattamento PVD

OLV ottone lucido verniciato

CS ottone cromato satinato

CR ottone cromato lucido

BG ottone bronzato graffiato

1502 Bocchetta a baionetta mm 10

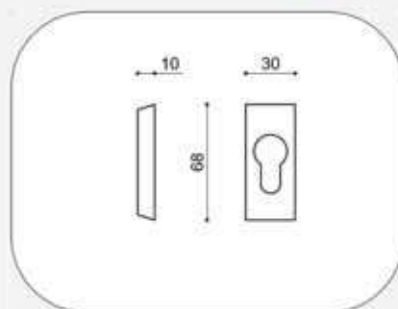

bocchetta di sicurezza rettangolare con foro yale e fori vite nascosti, montaggio a baionetta

finiture:

PVD ottone con trattamento PVD

OLV ottone lucido verniciato

CS ottone cromato satinato

CR ottone cromato lucido

BG ottone bronzato graffiato

1503 Bocchetta a baionetta mm 6

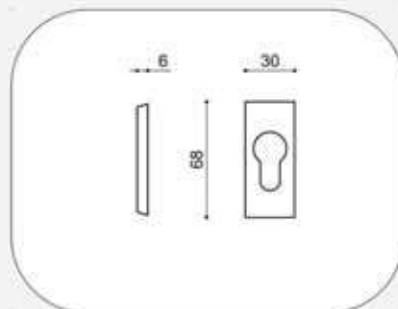

bocchetta di sicurezza rettangolare con foro yale e fori vite nascosti, montaggio a baionetta

finiture:

PVD ottone con trattamento PVD

OLV ottone lucido verniciato

CS ottone cromato satinato

CR ottone cromato lucido

BG ottone bronzato graffiato

1505 Placchetta foro yale

Ⓑ

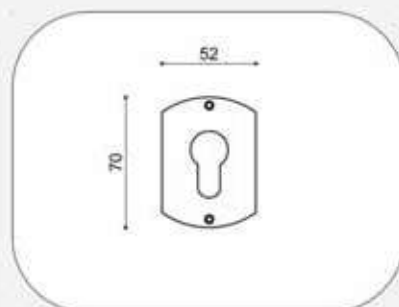

finiture:

OLV	ottone lucido verniciato
CS	ottone cromato satinato
CR	ottone cromato lucido
BG	ottone bronzato graffiato

1506 Placchetta doppia mappa

Ⓑ

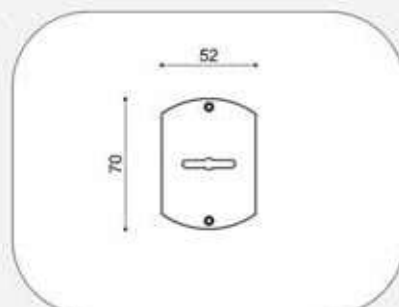

finiture:

OLV	ottone lucido verniciato
CS	ottone cromato satinato
CR	ottone cromato lucido
BG	ottone bronzato graffiato

1507 Placchetta doppia mappa con toppa ⓑ

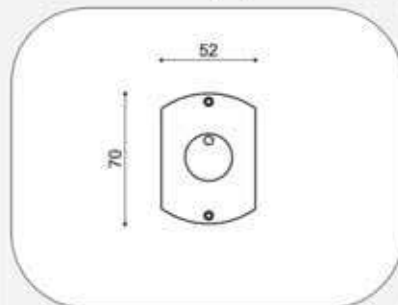

finiture:
OLV ottone lucido verniciato
CS ottone cromato satinato
CR ottone cromato lucido
BG ottone bronzato graffiato

1508 Placchetta foro yale ⓑ

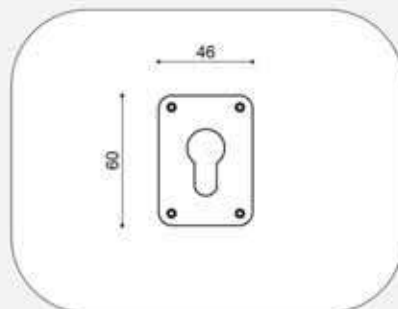

finiture:
OLV ottone lucido verniciato
CS ottone cromato satinato
CR ottone cromato lucido
BG ottone bronzato graffiato

1509 Placchetta doppia mappa

Ⓑ

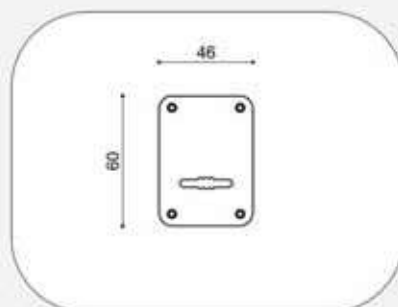

finiture:
OLV ottone lucido verniciato
CS ottone cromato satinato
CR ottone cromato lucido
BG ottone bronzato graffiato

1510 Placchetta doppia mappa con toppa

Ⓑ

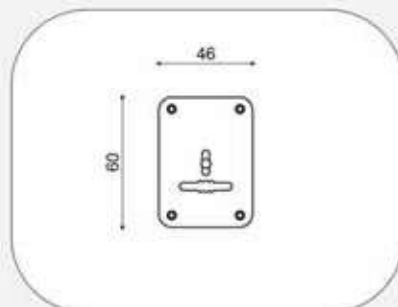

finiture:
OLV ottone lucido verniciato
CS ottone cromato satinato
CR ottone cromato lucido
BG ottone bronzato graffiato

1511 Placchetta con foro 10,3 mm

(B)

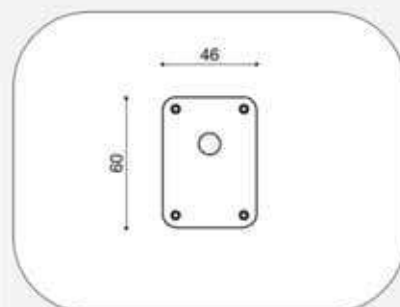

finiture:
OLV ottone lucido verniciato
CS ottone cromato satinato
CR ottone cromato lucido
BG ottone bronzato graffiato

156 Pomolo ovotto

(B)

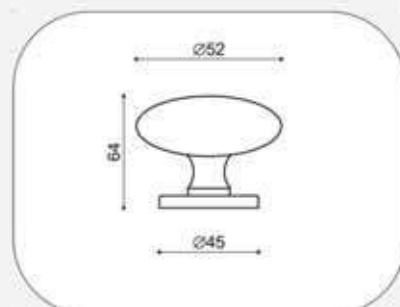

rosetta standard:
rosetta tonda d. 45 mm
varianti:
RO rosetta ovale

finiture:
OLV ottone lucido verniciato
CS ottone cromato satinato
CR ottone cromato lucido
BG ottone bronzato graffiato

165 Pomolo olivetta

(B)

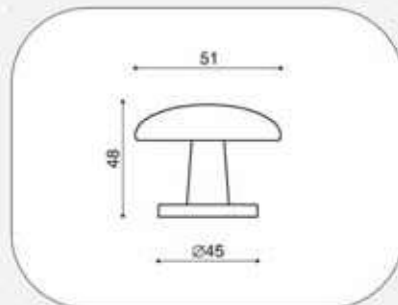

rosetta standard:
rosetta tonda d. 45 mm
varianti:
RO rosetta ovale

finiture:
OLV ottone lucido verniciato
CS ottone cromato satinato
CR ottone cromato lucido
BG ottone bronzato graffiato

153 Pomolo smart

(B)



rosetta standard:
rosetta tonda d. 45 mm
varianti:
RO rosetta ovale

finiture:
OLV ottone lucido verniciato
CS ottone cromato satinato
CR ottone cromato lucido
BG ottone bronzato graffiato

155 Pomolo lux

pvd (B)

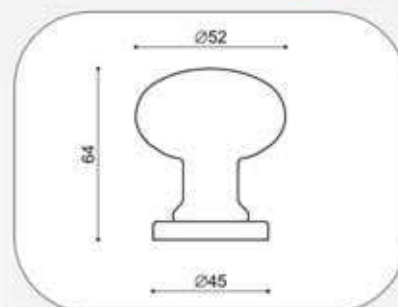

rosetta standard:
rosetta tonda d. 45 mm
varianti:
RO rosetta ovale

finiture:
PVD ottone con trattamento PVD
OLV ottone lucido verniciato
SV ottone satinato verniciato
CS ottone cromato satinato
CR ottone cromato lucido
ANT ottone bronzo antico
ORO ottone oro antico
ARG ottone argento antico
RAM ottone ramato antico
BG ottone bronzato graffiato

1521 Pomolo limitatore d.40 mm

(B)

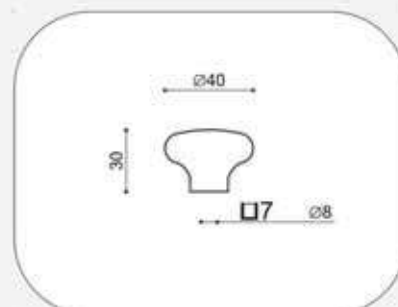

standard:
senza rosetta
varianti:
R45 rosetta tonda d. 45mm

finiture:
OLV ottone lucido verniciato
CS ottone cromato satinato
CR ottone cromato lucido

1522 Pomolo limitatore d.48 mm

(B)

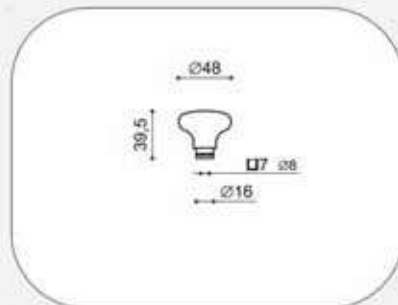

standard:
R45 rosetta tonda d. 45 mm
varianti:
RO rosetta ovale

finiture:
OLV ottone lucido verniciato
CS ottone cromato satinato
CR ottone cromato lucido

1523 Pomolino di rotazione farfalla

(B)

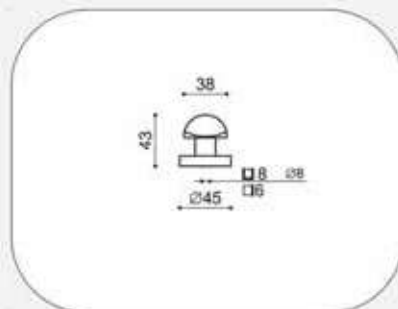

standard:
R45 rosetta tonda d. 45 mm
varianti:
RO rosetta ovale
SR senza rosetta

speciale:
SV senza rosetta e senza vasetto

finiture:
OLV ottone lucido verniciato
CS ottone cromato satinato
CR ottone cromato lucido
BG ottone bronzato graffiato

1903 Quadro ad espansione

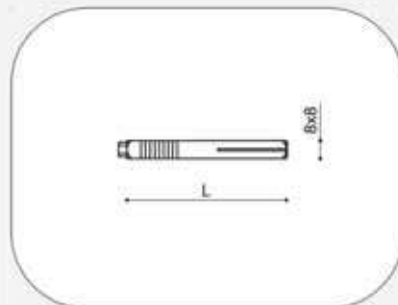

versioni:

- art. 1903-65 quadro ad espansione L : mm 65
- art. 1903-80 quadro ad espansione L : mm 80
- art. 1903-90 quadro ad espansione L : mm 90

finiture:

ferro zincato argento

1920 Quadro con niples

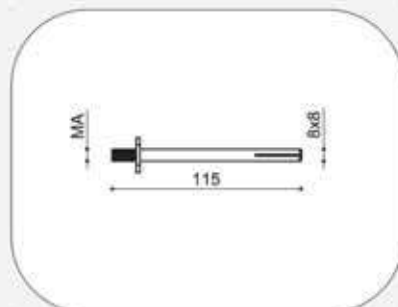

versioni:

- art. 1920 quadro con niples MA 10
- art. 1921 quadro con niples MA 12
- art. 1922 quadro con niples MA 14

finiture:

ferro + ottone zincato argento

1200 Bocchetta di sicurezza d. 55

pvd (B)

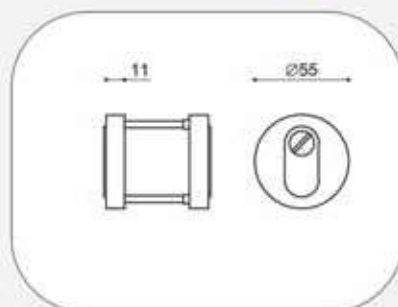

bocchetta di sicurezza d. 55 mm con cilindro regolabile per sporgenze da 10 a 15 mm con sottobocchetta in acciaio temprato antitrapano

finiture:

PVD ottone con trattamento PVD

OLV ottone lucido verniciato

CS ottone cromato satinato

CR ottone cromato lucido

BG ottone bronzato graffiato

1210 Bocchetta di sicurezza d. 52

pvd (B)

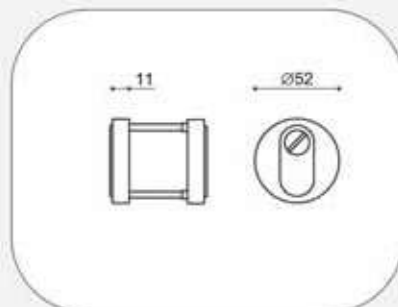

bocchetta di sicurezza d. 52 mm con cilindro regolabile per sporgenze da 10 a 15 mm con sottobocchetta in acciaio temprato antitrapano

finiture:

PVD ottone con trattamento PVD

OLV ottone lucido verniciato

CS ottone cromato satinato

CR ottone cromato lucido

BG ottone bronzato graffiato

1230 Bocchetta di sicurezza d. 52

pvd (B)

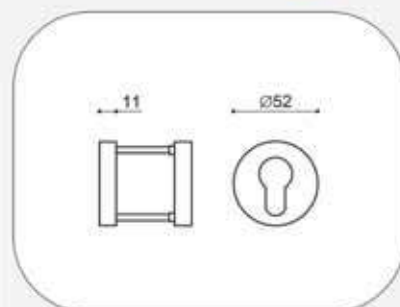

bocchetta di sicurezza d. 52 mm con foro yale con sottobocchetta in acciaio temprato antitrapano

finiture:

PVD ottone con trattamento PVD

OLV ottone lucido verniciato

CS ottone cromato satinato

CR ottone cromato lucido

BG ottone bronzato graffiato

1235 Bocchetta di sicurezza ovale

pvd (B)

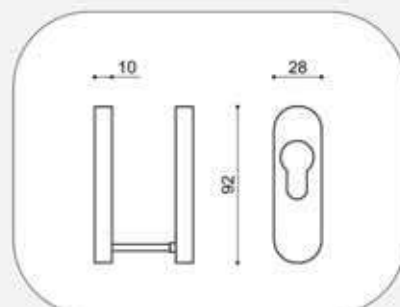

bocchetta di sicurezza ovale con foro yale con sottobocchetta in acciaio temprato antitrapano

finiture:

PVD ottone con trattamento PVD

OLV ottone lucido verniciato

CS ottone cromato satinato

CR ottone cromato lucido

BG ottone bronzato graffiato

— porte hotel

KIT PORTA INGRESSO:

Grazie all'assortimento dei prodotti si possono realizzare kit per porta d'ingresso / porte hotel personalizzati, abbinando maniglia / pomolo con i vari montaggi su rosetta e placca in modo da aver un prodotto specifico per ogni esigenza, personalizzabile anche il sistema di fissaggio che può esser realizzato tramite quadro ad espansione, quadro nipples o quadro con piastrino.



sistemi di fissaggio disponibili pag. 366/367/368
maniglia / pomolo : gamma completa Mariva

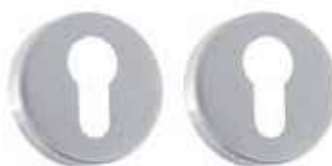

— porte hotel

KIT PORTA INTERNA:

Grazie all'assortimento dei prodotti si possono realizzare kit per porta d'ingresso / porte hotel personalizzati, abbinando maniglia / pomolo con i vari montaggi su rosetta e placca in modo da aver un prodotto specifico per ogni esigenza, personalizzabile anche nel sistema del nottolino Wc abbinando il libero occupato con finestra o con pulsante di emergenza in ottone





Supporti corrimano



103
Supporto
pag. 240



107
Supporto
pag. 240



108
Supporto
pag. 241



108C
Supporto
pag. 241



109
Supporto
pag. 242



110
Supporto
pag. 242



111
Supporto
pag. 243



112
Supporto
pag. 243



113
Supporto
pag. 244



114
Supporto
pag. 244



115
Supporto per tubo
pag. 245



116
Supporto per tubo
pag. 245



119
Finale per tubo
pag. 246



1115
Tubo per corr.
pag. 246



1800
Supporto easy
pag. 247



1805
Anello di giunzione
pag. 247



1810
Finale con vite
pag. 248



1815
Finale con vite
pag. 248



1816
Supp. per corda
pag. 249



1817
Finale per corda
pag. 249

103

Supporto corrimano testa piana

Ⓑ

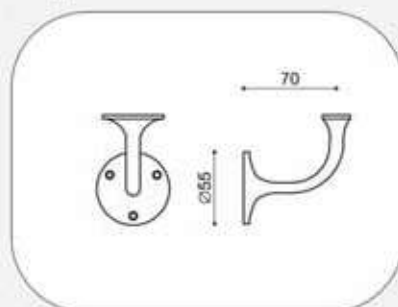

finiture:

- OLV ottone lucido verniciato
- CS ottone cromato satinato
- CR ottone cromato lucido
- BV ottone bronzato verniciato

107

Supporto corrimano quadro

Ⓑ

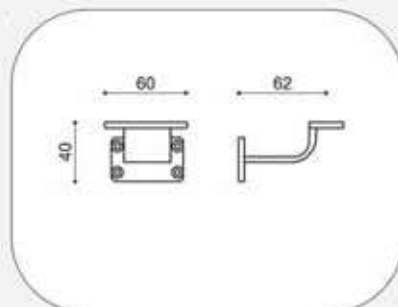

finiture:

- OLV ottone lucido verniciato
- SV ottone satinato verniciato
- CS ottone cromato satinato
- CR ottone cromato lucido
- NKS ottone nickel satinato verniciato
- ANT ottone bronzo antico
- ORO ottone oro antico
- ARG ottone argento antico
- BV ottone bronzato verniciato

108

Supporto corrimano testa piana

Ⓑ

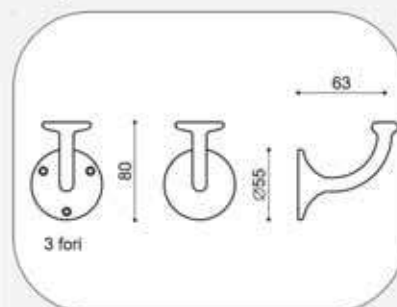

versione standard:
art. 108 supporto con troncone M8
variante:
art. 1083F supporto con 3 fori vite

finiture:
OLV ottone lucido verniciato
CS ottone cromato satinato
CR ottone cromato lucido
ANT ottone bronzo antico
BV ottone bronzato verniciato

108C

Supporto corrimano testa concava

Ⓑ

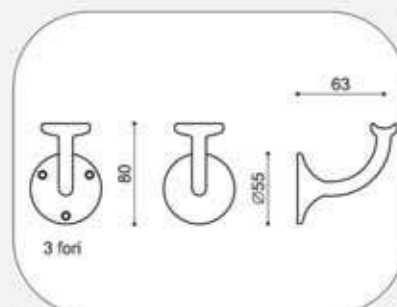

versione standard:
art. 108C supporto con troncone M8
variante:
art. 108C3F supporto con 3 fori vite

finiture:
OLV ottone lucido verniciato
CS ottone cromato satinato
CR ottone cromato lucido
ANT ottone bronzo antico
BV ottone bronzato verniciato

109 Supporto corrimano testa concava

ⓑ

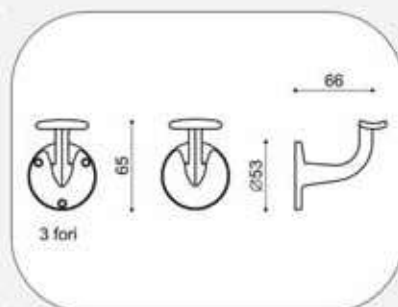

versione standard:

art. 109 supporto con troncone M8

variante:

art. 1093F supporto con 3 fori vite

finiture:

OLV	ottone lucido verniciato
CS	ottone cromato satinato
CR	ottone cromato lucido
NKS	ottone nikel satinato verniciato
ANT	ottone bronzato antico
ORO	ottone oro antico
ARG	ottone argento antico
BV	ottone bronzato verniciato
NO	ottone verniciato nero opaco

110 Supporto corrimano testa piana

ⓑ

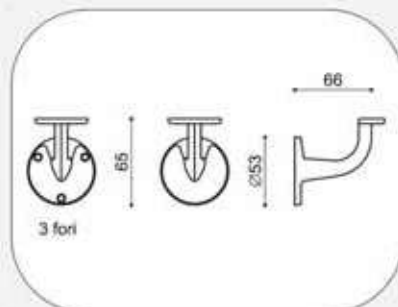

versione standard:

art. 110 supporto con troncone M8

variante:

art. 1103F supporto con 3 fori vite

finiture:

OLV	ottone lucido verniciato
CS	ottone cromato satinato
CR	ottone cromato lucido
NKS	ottone nikel satinato verniciato
ANT	ottone bronzato antico
ORO	ottone oro antico
ARG	ottone argento antico
BV	ottone bronzato verniciato
NO	ottone verniciato nero opaco

111

Supporto corrimano testa piana

Ⓑ

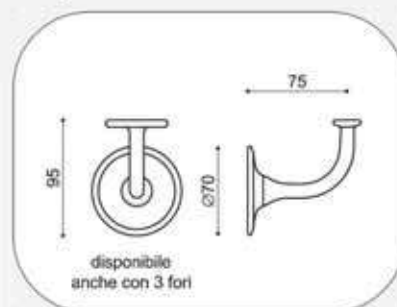

versione standard:
art. 111 supporto con troncone M8
variante:
art. 1113F supporto con 3 fori vite

finiture:
OLV ottone lucido verniciato
CS ottone cromato satinato
CR ottone cromato lucido
NKS ottone nikel satinato verniciato
ANT ottone bronzato antico
BV ottone bronzato verniciato
NO ottone verniciato nero opaco

112

Supporto corrimano testa concava

Ⓑ

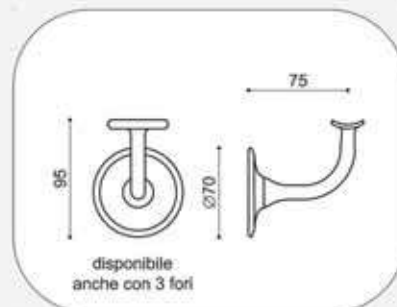

versione standard:
art. 112 supporto con troncone M8
variante:
art. 1123F supporto con 3 fori vite

finiture:
OLV ottone lucido verniciato
CS ottone cromato satinato
CR ottone cromato lucido
NKS ottone nikel satinato verniciato
ANT ottone bronzato antico
BV ottone bronzato verniciato
NO ottone verniciato nero opaco

113

Supporto corrimano testa piana

ⓑ

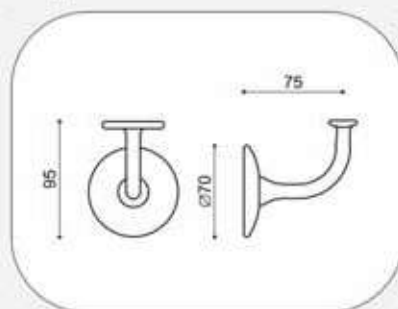

finiture:

- OLV ottone lucido verniciato
- CS ottone cromato satinato
- CR ottone cromato lucido
- BV ottone bronzato verniciato

114

Supporto corrimano testa concava

ⓑ

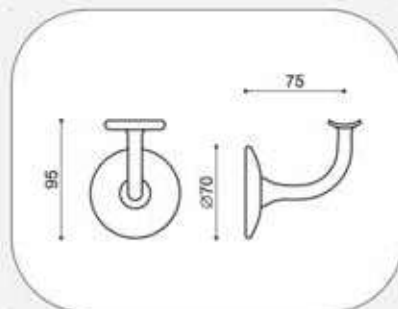

finiture:

- OLV ottone lucido verniciato
- CS ottone cromato satinato
- CR ottone cromato lucido
- BV ottone bronzato verniciato

115 Supporto corrimano per tubo

Ⓑ

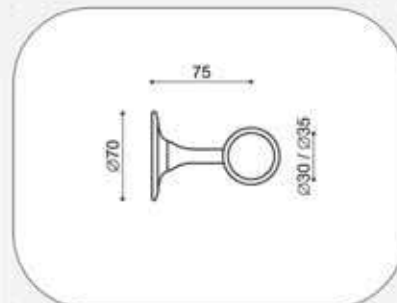

versioni:
art. 115 30 supporto per tubo d. 30 mm
art. 115 35 supporto per tubo d. 35 mm

finiture:
OLV ottone lucido verniciato
CS ottone cromato satinato

116 Supporto corrimano per tubo

Ⓑ

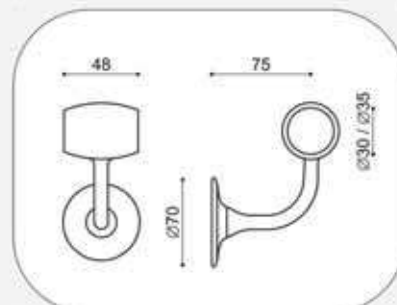

versioni:
art. 116 30 supporto per tubo d. 30 mm
art. 116 35 supporto per tubo d. 35 mm

finiture:
OLV ottone lucido verniciato
CS ottone cromato satinato

119

Finale per tubo

Ⓑ

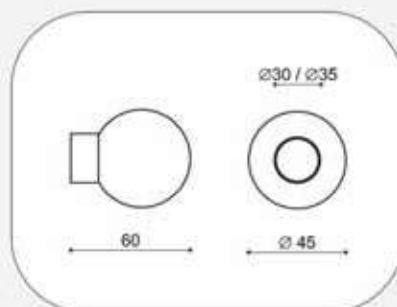

versioni:
art. 119 30 supporto per tubo d. 30 mm
art. 119 35 supporto per tubo d. 35 mm

finiture:
OLV ottone lucido verniciato
CS ottone cromato satinato

1115

Tubo per corrimano

Ⓑ

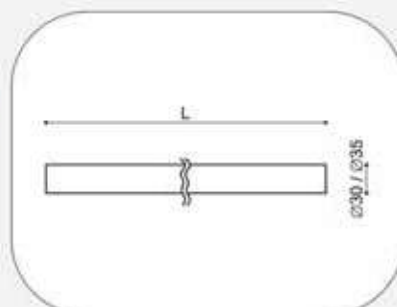

versioni:
art. 1115 30 tubo d. 30 mm
art. 1115 35 tubo d. 35 mm

lunghezze disponibili:
150 cm
200 cm
250 cm
300 cm

finiture:
OLV ottone lucido verniciato
CS ottone cromato satinato

1800 Supporto corrimano Easy

Ⓑ

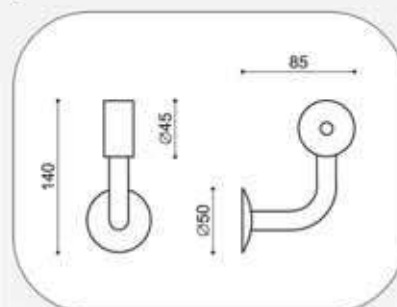

finiture:
OLV ottone lucido verniciato
CS ottone cromato satinato

1805 Anello di giunzione d. 50 mm

Ⓑ

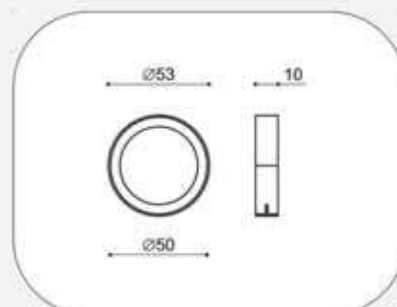

finiture:
OLV ottone lucido verniciato
CS ottone cromato satinato
BIA ottone verniciato bianco
NERO ottone verniciato nero

1810 Finale con vite interna

ⓑ

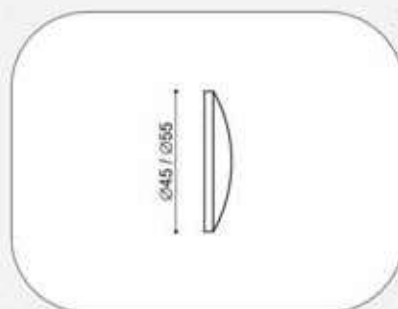

versioni:

art. 1810 45 : diametro 45 mm
art. 1810 55 : diametro 55 mm

finiture:

OLV ottone lucido verniciato
CS ottone cromato satinato
CR ottone cromato lucido
BV ottone bronzato verniciato

1815 Finale con vite esterna

ⓑ



versioni:

art. 1815 45 : diametro 45 mm
art. 1815 50 : diametro 50 mm

finiture:

OLV ottone lucido verniciato
CS ottone cromato satinato
CR ottone cromato lucido
BV ottone bronzato verniciato

1816 Supporto per corda d. 30

Ⓑ

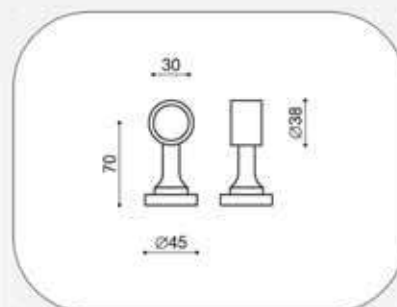

finiture:
OLV ottone lucido verniciato
CS ottone cromato satinato
CR ottone cromato lucido

1817 Finale per corda d. 30

Ⓑ

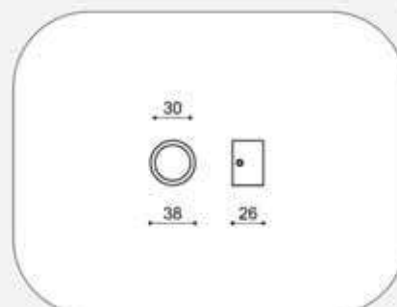

finiture:
OLV ottone lucido verniciato
CS ottone cromato satinato
CR ottone cromato lucido



50

pag. 252



5050

pag. 252



4050

pag. 253



8050

pag. 253



51

pag. 254



5051

pag. 254



4051

pag. 255



8051

pag. 255



53

pag. 256



5053

pag. 256

kit Ovali e Rettangolari per porte scorrevoli



4053
pag. 257



70
pag. 262



4071
pag. 267



8053
pag. 257



5070
pag. 262



8071
pag. 267



53C
pag. 258



4070
pag. 263



71B
pag. 268



5053C
pag. 258



8070
pag. 263



5071B
pag. 268



4053C
pag. 259



70B
pag. 264



4071B
pag. 269



8053C
pag. 259



5070B
pag. 264



8071B
pag. 269



53Y
pag. 260



4070B
pag. 265



4070BC
pag. 270



5053Y
pag. 260



8070B
pag. 265



8070BC
pag. 270



4053Y
pag. 261



71
pag. 266



4071BC
pag. 271



8053Y
pag. 261



5071
pag. 266



8071BC
pag. 271

50

Kit ovale con pomolino ribassato

(B)

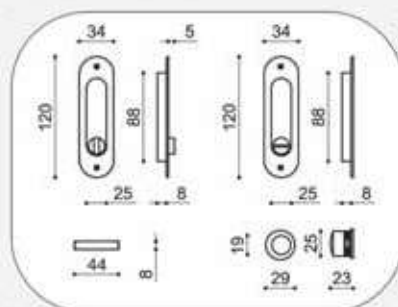

versioni:

50CS : con serratura art. 1690 pag. 299
50SS : senza serratura

finiture:

OLV ottone lucido verniciato
SV ottone satinato verniciato
CS ottone cromato satinato
CR ottone cromato lucido
ANT ottone bronzo antico
ORO ottone oro antico
ARG ottone argento antico
RAM ottone ramato antico
BG ottone bronzato graffiato

5050

Kit ovale con pomolino ribassato

(S)

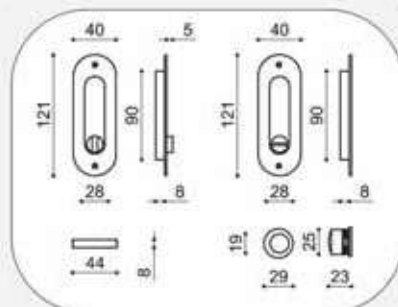

versioni:

5050CS : con serratura art. 1690 pag. 299
5050SS : senza serratura

finiture:

MORO maritech oro lucido
MCS maritech cromato satinato

4050 Kit rettangolare con pom. ribassato

(B)

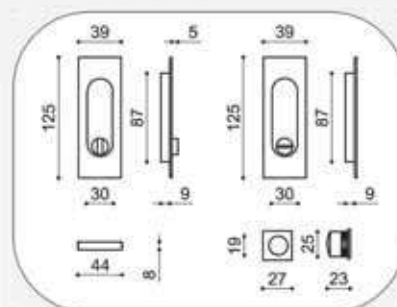
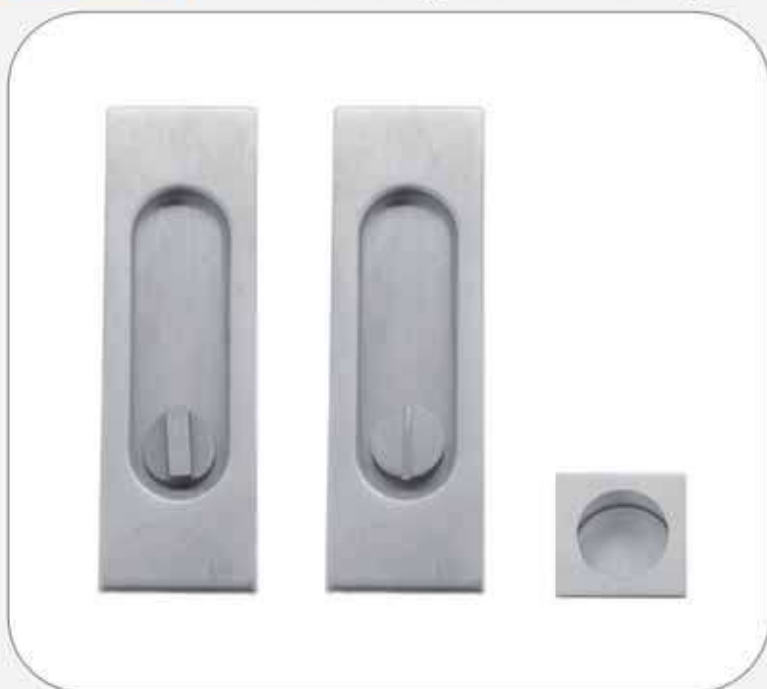

versioni:

4050CS : con serratura art. 1690 pag. 299
4050SS : senza serratura

finiture:

OLV ottone lucido verniciato
CS ottone cromato satinato
CR ottone cromato lucido

8050 Kit ovale con pomolino ribassato

(B)

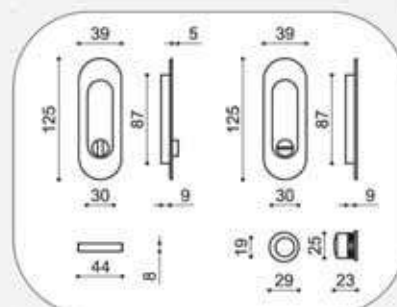

versioni:

8050CS : con serratura art. 1690 pag. 299
8050SS : senza serratura

finiture:

OLV ottone lucido verniciato
CS ottone cromato satinato
CR ottone cromato lucido
BG ottone bronzato graffiato

51 Kit ovale cieco

Ⓑ

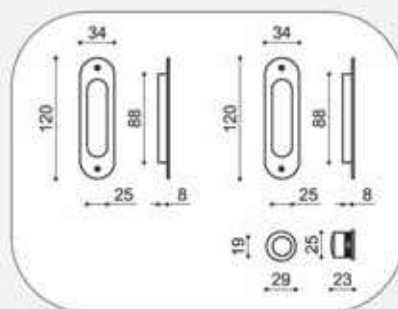

finiture:

- OLV ottone lucido verniciato
- SV ottone satinato verniciato
- CS ottone cromato satinato
- CR ottone cromato lucido
- ANT ottone bronzo antico
- ORO ottone oro antico
- ARG ottone argento antico
- RAM ottone ramato antico
- BG ottone bronzato graffiato

5051 Kit ovale cieco

Ⓜ

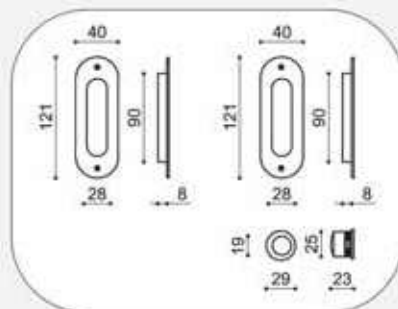

finiture:

- MORO maritech oro lucido
- MCS maritech cromato satinato

4051 Kit rettangolare cieco

(B)

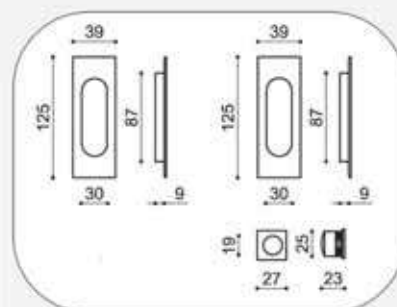

finiture:
 OLV ottone lucido verniciato
 CS ottone cromato satinato
 CR ottone cromato lucido

8051 Kit ovale cieco

(B)

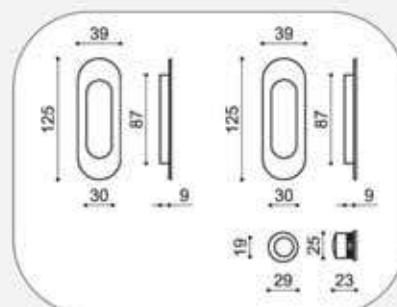

finiture:
 OLV ottone lucido verniciato
 CS ottone cromato satinato
 CR ottone cromato lucido
 BG ottone bronzato graffiato

53

Kit ovale con foro chiave basso

ⓑ

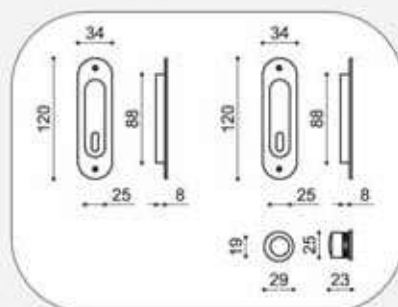

versioni:
 53CS : con serratura art. 1680 pag. 298
 e chiave snodata
 53SS : senza serratura

finiture:
 OLV ottone lucido verniciato
 SV ottone satinato verniciato
 CS ottone cromato satinato
 CR ottone cromato lucido
 ANT ottone bronzo antico
 ORO ottone oro antico
 ARG ottone argento antico
 RAM ottone ramato antico
 BG ottone bronzato graffiato

5053

Kit ovale con foro chiave basso

Ⓜ

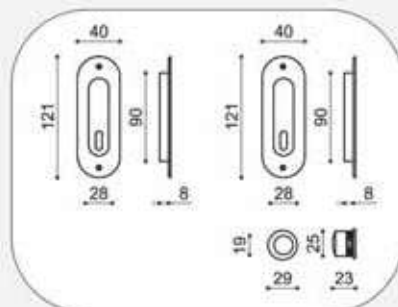

versioni:
 5053CS : con serratura art. 1680 pag. 298
 e chiave snodata
 5053SS : senza serratura

finiture:
 MORO maritech oro lucido
 MCS maritech cromato satinato

4053 Kit rettangolare con foro chiave basso [ⓑ]

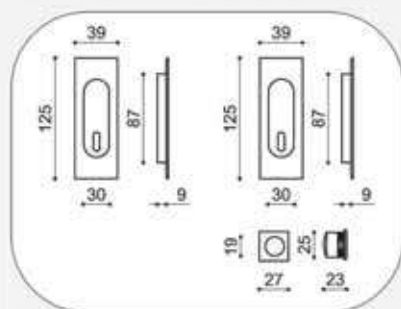

versioni:

4053CS : con serratura art. 1680 pag. 298
e chiave snodata

4053SS : senza serratura

finiture:

OLV : ottone lucido verniciato
CS : ottone cromato satinato
CR : ottone cromato lucido

8053 Kit ovale con foro chiave basso [ⓑ]

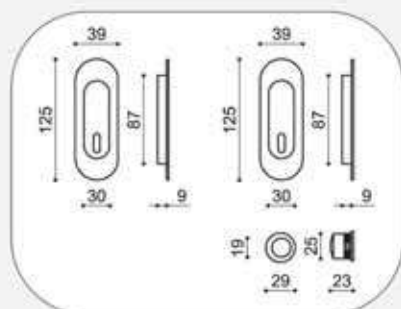

versioni:

8053CS : con serratura art. 1680 pag. 298
e chiave snodata

8053SS : senza serratura

finiture:

OLV : ottone lucido verniciato
CS : ottone cromato satinato
CR : ottone cromato lucido
BG : ottone bronzato graffiato

53C Kit ovale con foro chiave centrale

(B)

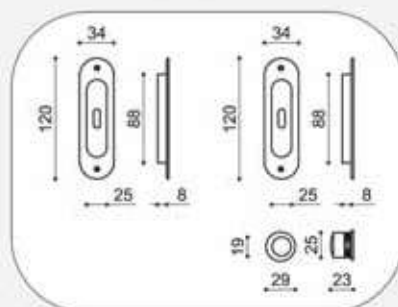

versioni:
 53CCS : con serratura art. 1680 pag. 298
 e chiave snodata
 53CSS : senza serratura

finiture:
 OLV ottone lucido verniciato
 SV ottone satinato verniciato
 CS ottone cromato satinato
 CR ottone cromato lucido
 ANT ottone bronzo antico
 ORO ottone oro antico
 ARG ottone argento antico
 RAM ottone ramato antico
 BG ottone bronzato graffiato

5053C Kit ovale con foro chiave centrale

(S)

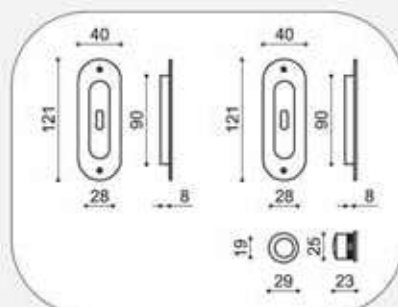

versioni:
 5053CCS : con serratura art. 1680 pag. 298
 e chiave snodata
 5053CSS : senza serratura

finiture:
 MORO maritech oro lucido
 MCS maritech cromato satinato

4053C Kit rett. con foro chiave centrale

Ⓑ

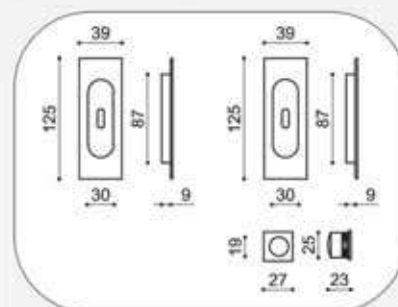

versioni:

4053CCS : con serratura art. 1680 pag. 298
e chiave snodata
4053CSS : senza serratura

finiture:

OLV ottone lucido verniciato
CS ottone cromato satinato
CR ottone cromato lucido

8053C Kit ovale con foro chiave centrale

Ⓑ

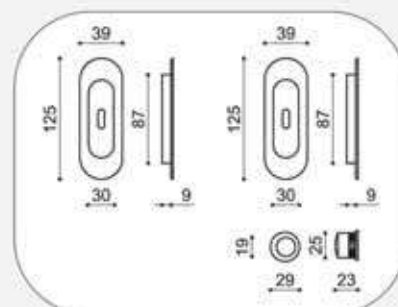

versioni:

8053CCS : con serratura art. 1680 pag. 298
e chiave snodata
8053CSS : senza serratura

finiture:

OLV ottone lucido verniciato
CS ottone cromato satinato
CR ottone cromato lucido
BG ottone bronzato graffiato

53Y Kit ovale con foro chiave yale

Ⓑ

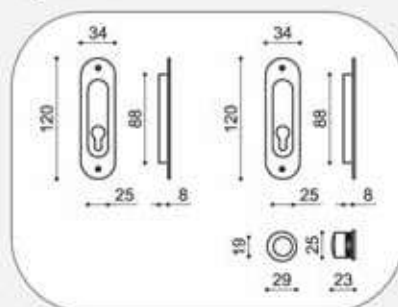

versioni:

53YCS : con serratura art. 1680Y pag. 298
senza cilindro
53YSS : senza serratura

finiture:

OLV ottone lucido verniciato
SV ottone satinato verniciato
CS ottone cromato satinato
CR ottone cromato lucido
ANT ottone bronzo antico
ORO ottone oro antico
ARG ottone argento antico
RAM ottone ramato antico
BG ottone bronzato graffiato

5053Y Kit ovale con foro chiave yale

Ⓜ

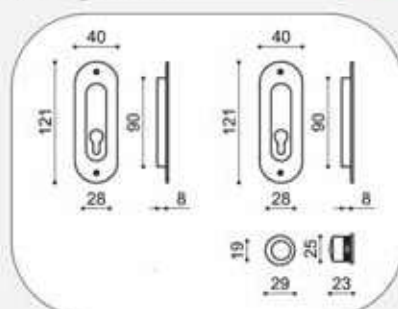

versioni:

5053YCS : con serratura art. 1680Y pag. 298
senza cilindro
5053YSS : senza serratura

finiture:

MORO maritech oro lucido
MCS maritech cromato satinato

4053Y

Kit rettangolare con foro chiave yale [ⓑ]

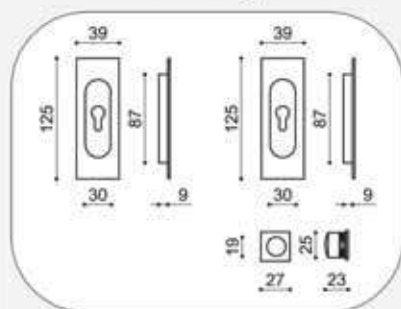

versioni:

4053YCS : con serratura art. 1680Y pag. 298
senza cilindro

4053YSS : senza serratura

finiture:

OLV : ottone lucido verniciato
CS : ottone cromato satinato
CR : ottone cromato lucido

8053Y

Kit ovale con foro chiave yale [ⓑ]

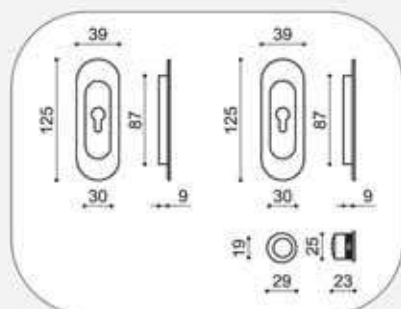

versioni:

8053YCS : con serratura art. 1680Y pag. 298
senza cilindro

8053YSS : senza serratura

finiture:

OLV : ottone lucido verniciato
CS : ottone cromato satinato
CR : ottone cromato lucido
BG : ottone bronzato graffiato

70 Kit ovale con pendente

(B)

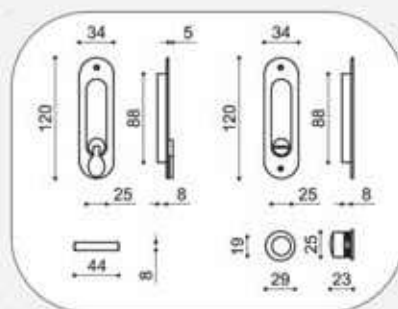

versioni:

70CS : con serratura art. 1690 pag. 299
70SS : senza serratura

finiture:

OLV ottone lucido verniciato
SV ottone satinato verniciato
CS ottone cromato satinato
CR ottone cromato lucido
ANT ottone bronzo antico
ORO ottone oro antico
ARG ottone argento antico
RAM ottone ramato antico
BG ottone bronzato graffiato

5070 Kit ovale con pendente

(S)

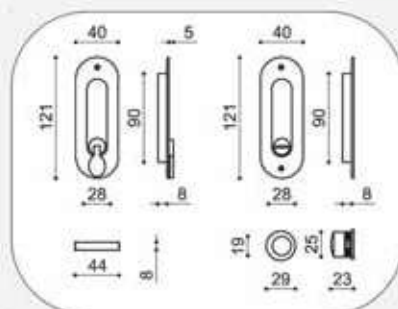

versioni:

5070CS : con serratura art. 1690 pag. 299
5070SS : senza serratura

finiture:

MORO maritech oro lucido
MCS maritech cromato satinato

4070 Kit rettangolare con pendente

(B)

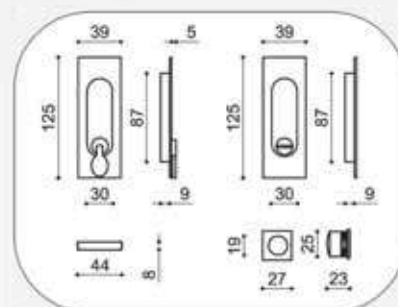

versioni:
4070CS : con serratura art. 1690 pag. 299
4070SS : senza serratura

finiture:
OLV ottone lucido verniciato
CS ottone cromato satinato
CR ottone cromato lucido

8070 Kit ovale con pendente

(B)

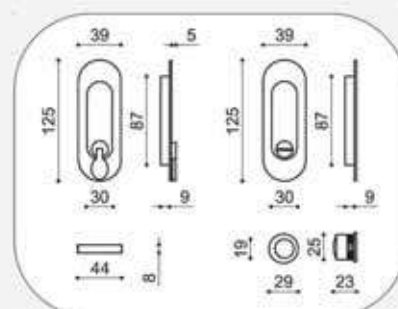

versioni:
8070CS : con serratura art. 1690 pag. 299
8070SS : senza serratura

finiture:
OLV ottone lucido verniciato
CS ottone cromato satinato
CR ottone cromato lucido
BG ottone bronzato graffiato

70B Kit ovale con pendente basso

(B)

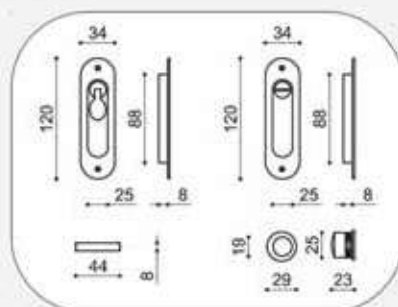

versioni:

70BCS : con serratura art. 1690 pag. 299
70BSS : senza serratura

finiture:

OLV ottone lucido verniciato
SV ottone satinato verniciato
CS ottone cromato satinato
CR ottone cromato lucido
ANT ottone bronzo antico
ORO ottone oro antico
ARG ottone argento antico
RAM ottone ramato antico
BG ottone bronzato graffiato

5070B Kit ovale con pendente basso

(S)

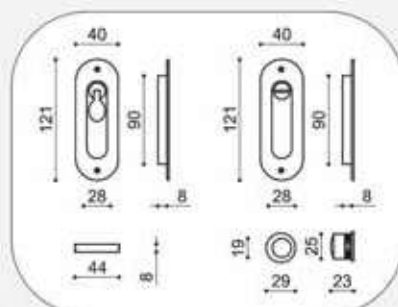

versioni:

5070BCS : con serratura art. 1690 pag. 299
5070BSS : senza serratura

finiture:

MORO maritech oro lucido
MCS maritech cromato satinato

4070B Kit rettangolare con pendente basso [ⓑ]

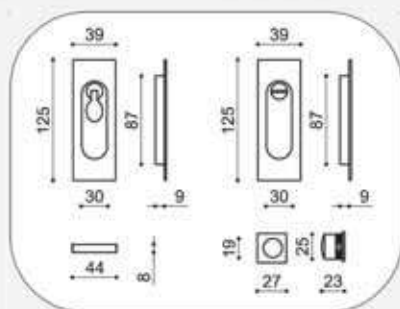

versioni:
 4070BCS : con serratura art. 1690 pag. 299
 4070BSS : senza serratura

finiture:
 OLV : ottone lucido verniciato
 CS : ottone cromato satinato
 CR : ottone cromato lucido

8070B Kit ovale con pendente basso [ⓑ]

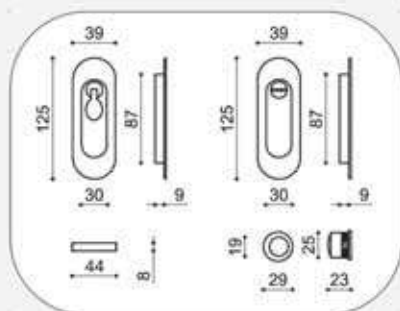

versioni:
 8070BCS : con serratura art. 1690 pag. 299
 8070BSS : senza serratura

finiture:
 OLV : ottone lucido verniciato
 CS : ottone cromato satinato
 CR : ottone cromato lucido
 BG : ottone bronzato graffiato

71

Kit ovale con due pendenti

Ⓑ

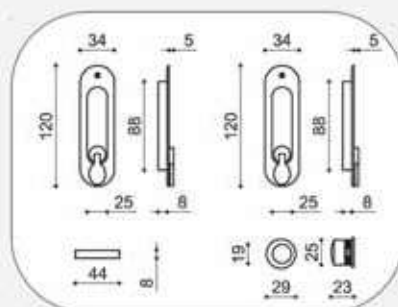

versioni:

71CS : con serratura art. 1690 pag. 299
 71SS : senza serratura

finiture:

OLV ottone lucido verniciato
 SV ottone satinato verniciato
 CS ottone cromato satinato
 CR ottone cromato lucido
 ANT ottone bronzo antico
 ORO ottone oro antico
 ARG ottone argento antico
 RAM ottone ramato antico
 BG ottone bronzato graffiato

5071

Kit ovale con due pendenti

Ⓜ

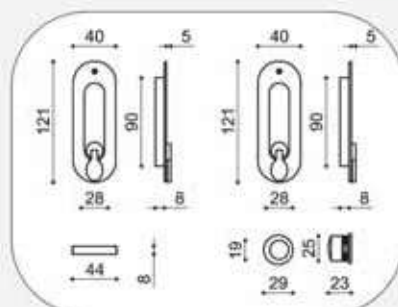

versioni:

5071CS : con serratura art. 1690 pag. 299
 5071SS : senza serratura

finiture:

MORO maritech oro lucido
 MCS maritech cromato satinato

4071 Kit rettangolare con due pendenti

Ⓑ

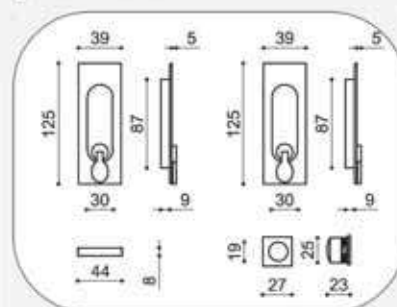

versioni:

4071CS : con serratura art. 1690 pag. 299
4071SS : senza serratura

finiture:

OLV ottone lucido verniciato
CS ottone cromato satinato
CR ottone cromato lucido

8071 Kit ovale con due pendenti

Ⓑ

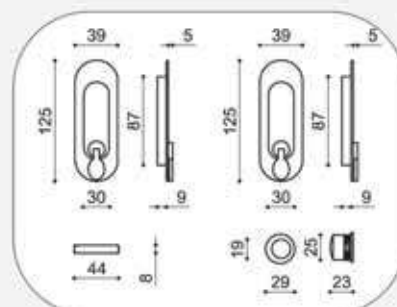

versioni:

8071CS : con serratura art. 1690 pag. 299
8071SS : senza serratura

finiture:

OLV ottone lucido verniciato
CS ottone cromato satinato
CR ottone cromato lucido
BG ottone bronzato graffiato

71B Kit ovale con due pendenti bassi

ⓑ

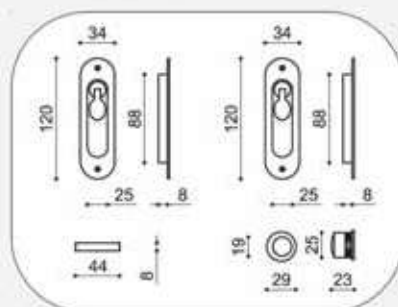

versioni:

71BCS : con serratura art. 1690 pag. 299
71BSS : senza serratura

finiture:

OLV ottone lucido verniciato
SV ottone satinato verniciato
CS ottone cromato satinato
CR ottone cromato lucido
ANT ottone bronzo antico
ORO ottone oro antico
ARG ottone argento antico
RAM ottone ramato antico
BG ottone bronzato graffiato

5071B Kit ovale con due pendenti bassi

Ⓜ

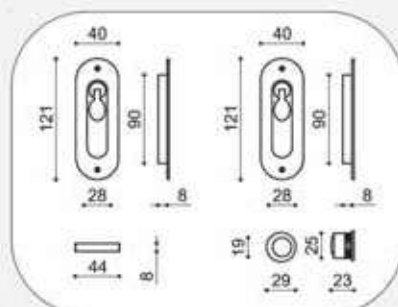

versioni:

5071BCS : con serratura art. 1690 pag. 299
5071BSS : senza serratura

finiture:

MORO maritech oro lucido
MCS maritech cromato satinato

4071B Kit rett. con due pendenti bassi

Ⓑ

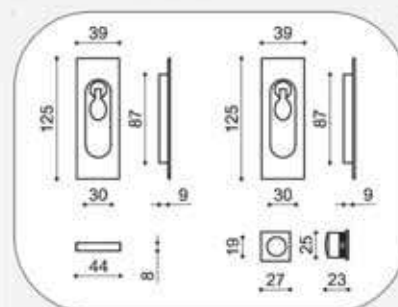

versioni:

4071BCS : con serratura art. 1690 pag. 299
4071BSS : senza serratura

finiture:

OLV : ottone lucido verniciato
CS : ottone cromato satinato
CR : ottone cromato lucido

8071B Kit ovale con due pendenti bassi

Ⓑ

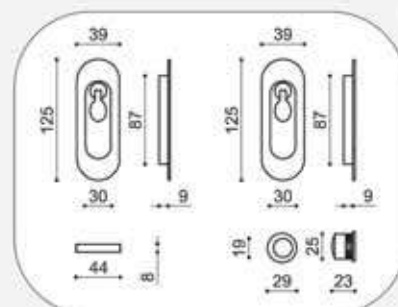

versioni:

8071BCS : con serratura art. 1690 pag. 299
8071BSS : senza serratura

finiture:

OLV : ottone lucido verniciato
CS : ottone cromato satinato
CR : ottone cromato lucido
BG : ottone bronzato graffiato

4070^{BC} Kit rett. con pend. basso centrale

ⓑ

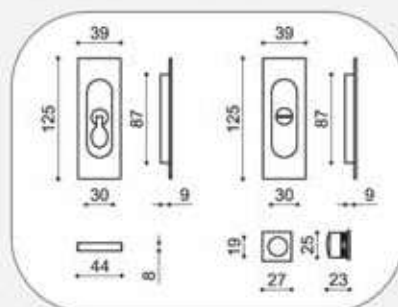

versioni:
 4070BCCS : con serratura art. 1690 pag. 299
 4070BCSS : senza serratura

finiture:
 OLV ottone lucido verniciato
 CS ottone cromato satinato
 CR ottone cromato lucido

8070^{BC} Kit ovale con pend. basso centrale

ⓑ

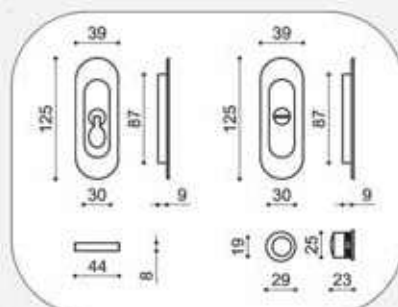

versioni:
 8070BCCS : con serratura art. 1690 pag. 299
 8070BCSS : senza serratura

finiture:
 OLV ottone lucido verniciato
 CS ottone cromato satinato
 CR ottone cromato lucido
 BG ottone bronzato graffiato

4071^{BC} Kit rett. con due pend. bassi cent. ⓑ

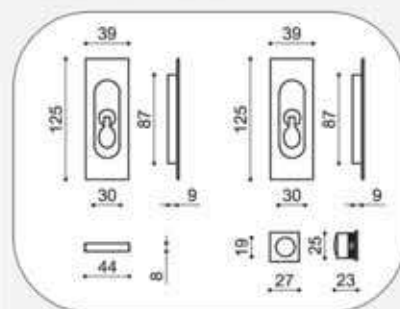

versioni:
 4071BCCS : con serratura art. 1690 pag. 299
 4071BCSS : senza serratura

finiture:
 OLV : ottone lucido verniciato
 CS : ottone cromato satinato
 CR : ottone cromato lucido



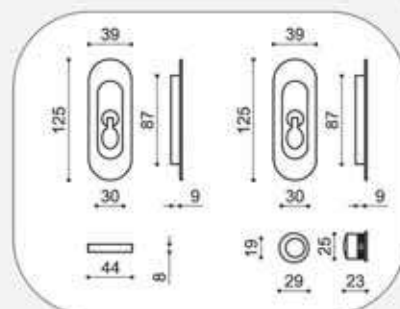





















8071^{BC} Kit ovale con due pend. bassi cent. ⓑ



versioni:
 8071BCCS : con serratura art. 1690 pag. 299
 8071BCSS : senza serratura

finiture:
 OLV : ottone lucido verniciato
 CS : ottone cromato satinato
 CR : ottone cromato lucido
 BG : ottone bronzato graffiato

Kit tondi per porte scorrevoli

	 2055 <i>pag. 278</i>	 85i <i>pag. 283</i>
	 2056 <i>pag. 278</i>	 86i <i>pag. 283</i>
	 55 <i>pag. 279</i>	 1074F <i>pag. 284</i>
	 56 <i>pag. 279</i>	 1054F <i>pag. 284</i>
	 81 <i>pag. 280</i>	 85F <i>pag. 285</i>
 K1 <i>pag. 274-275</i>	 82 <i>pag. 280</i>	 85iF <i>pag. 285</i>
 2074 <i>pag. 276</i>	 55Y <i>pag. 281</i>	 77 <i>pag. 286</i>
 1074 <i>pag. 276</i>	 1064 <i>pag. 281</i>	 77B <i>pag. 286</i>
 74 <i>pag. 277</i>	 85 <i>pag. 282</i>	 8532 <i>pag. 287</i>
 54 <i>pag. 277</i>	 86 <i>pag. 282</i>	 8632 <i>pag. 287</i>

— K1: caratteristiche tecniche - vantaggi

- Impugnatura che permette di **spingere e tirare** il nottolino



Grazie al nuovo nottolino si ha una presa notevolmente migliorata che oltre al normale utilizzo di apertura/chiusura della serratura e dello spostamento della scorrevole permette di essere utilizzato anche sulle porte pieghevoli dove è necessario tirare la porta.

- Nuovo pomolino d'emergenza più **sicuro**

Col nuovo pomolino d'emergenza si ha sempre la certezza di avere il taglio cacciavite libero dalla vite di regolazione, questo garantisce una maggiore sicurezza in caso di necessità. Inoltre, grazie alla forma rialzata è possibile, azionare la serratura anche con l'ausilio di una pinza, garantendo una doppia sicurezza.



K1 - spessori porta

new

- Regolazione standard di 12 mm: per porte con **spessore da 38 a 50 mm**

Grazie al nuovo sistema a doppio quadro si ha una regolazione standard di 12 mm, che permette di utilizzare lo stesso kit per porte di spessore compreso tra i 38 ed i 50 mm senza la necessità di dover tagliare o allungare i quadri.

Grazie a questo sistema si ha un notevole risparmio del tempo di montaggio e senza possibilità di errori.

Con l'ausilio di una riduzione il kit può essere utilizzato per porte di spessore fino a 56 mm



K1 Kit tondo con pomolino basso reg.

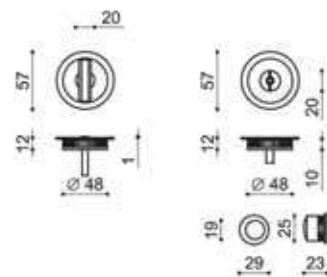

versioni:

K1CS : con serratura art. 1690 pag. 271

K1SS : senza serratura

spessore porta standard:

di serie da 38 a 50 mm

disponibile riduzione e vite per aumentare lo spessore fino a 56 mm utilizzando lo stesso kit K1

finiture:

MORO maritech oro lucido

MCS maritech cromato satinato

MCR maritech cromato lucido

MBG maritech bronzato graffiato

2074 Kit tondo con pomolino basso reg.

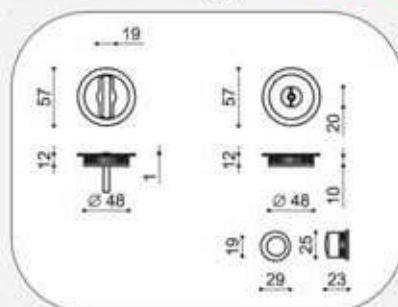

versioni:
 2074CS : con serratura art. 1690 pag. 299
 2074SS : senza serratura
spessore porta standard:
 di serie da 39 a 44 mm

disponibile anche da 44 a 48 mm
 su richiesta spessori speciali

finiture:
 MPVD maritech con trattamento PVD

MORO maritech oro lucido
MCS maritech cromato satinato
MCR maritech cromato lucido

1074 Kit tondo con pomolino basso reg.

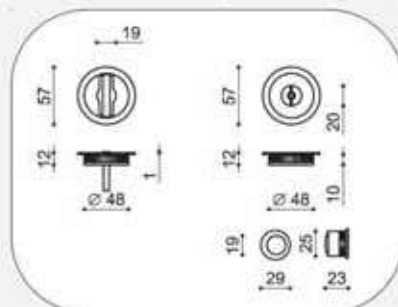

versioni:
 1074CS : con serratura art. 1690 pag. 299
 1074SS : senza serratura
spessore porta standard:
 di serie da 39 a 44 mm
 disponibile anche da 44 a 48 mm
 su richiesta spessori speciali

finiture:
 OLV ottone lucido verniciato
 SV ottone satinato verniciato
 CS ottone cromato satinato
 CR ottone cromato lucido
 ANT ottone bronzo antico
 ORO ottone oro antico
 ARG ottone argento antico
 RAM ottone ramato antico
 BG ottone bronzato graffiato

74

Kit tondo con pomolino basso

B

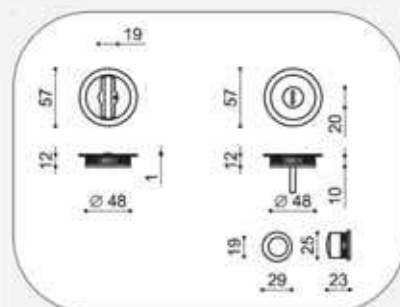

versioni:
art. 74CS: con serratura art. 1690 p. 299
art. 74SS: senza serratura

finiture:
OLV ottone lucido verniciato
SV ottone satinato verniciato
CS ottone cromato satinato
CR ottone cromato lucido
ANT ottone bronzo antico
ORO ottone oro antico
ARG ottone argento antico
RAM ottone ramato antico
BG ottone bronzato graffiato

54

Kit tondo con pomolino

B

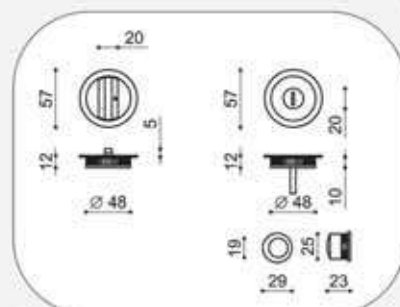

versioni:
art. 54CS: con serratura art. 1690 p. 299
art. 54SS: senza serratura

finiture:
OLV ottone lucido verniciato
SV ottone satinato verniciato
CS ottone cromato satinato
CR ottone cromato lucido
ANT ottone bronzo antico
ORO ottone oro antico
ARG ottone argento antico
RAM ottone ramato antico
BG ottone bronzato graffiato

2055 Kit tondo con foro chiave

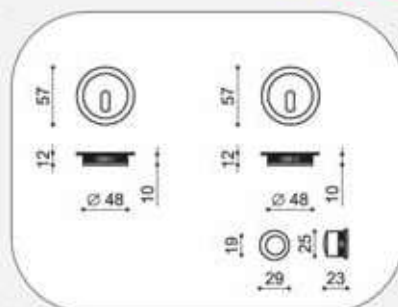

versioni:
 art. 2055CS: con serr. art. 1680 p. 298
 art. 2055SS: senza serratura

finiture:
 MPVD maritech con trattamento PVD

MORO maritech oro lucido
 MCS maritech cromato satinato
 MCR maritech cromato lucido

2056 Kit tondo cieco

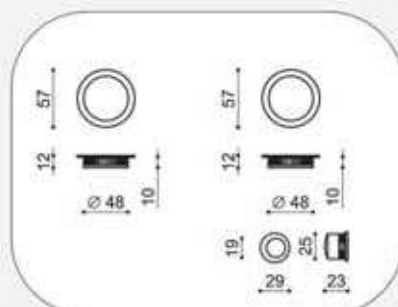

versioni:
 art. 2056SS: senza serratura

finiture:
 MPVD maritech con trattamento PVD

MORO maritech oro lucido
 MCS maritech cromato satinato
 MCR maritech cromato lucido

55

Kit tondo con foro chiave

(B)

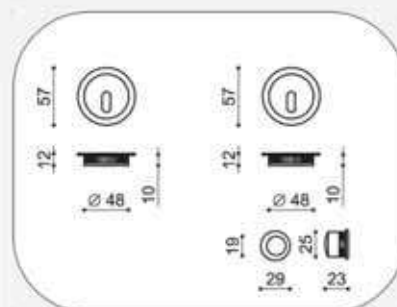

versioni:
art. 55CS: con serr. art. 1680 p. 298
art. 55SS: senza serratura

finiture:
OLV ottone lucido verniciato
SV ottone satinato verniciato
CS ottone cromato satinato
CR ottone cromato lucido
ANT ottone bronzo antico
ORO ottone oro antico
ARG ottone argento antico
RAM ottone ramato antico
BG ottone bronzato graffiato
BV ottone bronzo verniciato
BU ottone bronzo uniforme
NO ottone verniciato nero opaco
BIA ottone verniciato bianco

56

Kit tondo cieco

(B)

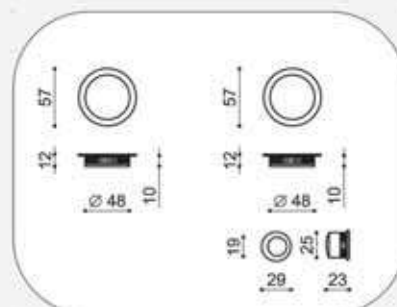

versioni:
art. 56SS: senza serratura

finiture:
OLV ottone lucido verniciato
SV ottone satinato verniciato
CS ottone cromato satinato
CR ottone cromato lucido
ANT ottone bronzo antico
ORO ottone oro antico
ARG ottone argento antico
RAM ottone ramato antico
BG ottone bronzato graffiato
BV ottone bronzo verniciato
BU ottone bronzo uniforme
NO ottone verniciato nero opaco
BIA ottone verniciato bianco

81

Kit tondo con due pomolini

Ⓑ

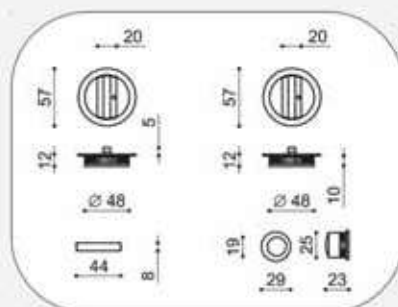

versioni:
art. 81CS: con serratura art. 1690 p. 299
art. 81SS: senza serratura

finiture:
OLV ottone lucido verniciato
SV ottone satinato verniciato
CS ottone cromato satinato
CR ottone cromato lucido
ANT ottone bronzo antico
ORO ottone oro antico
ARG ottone argento antico
RAM ottone ramato antico
BG ottone bronzato graffiato

82

Kit tondo con due pomolini bassi

Ⓑ

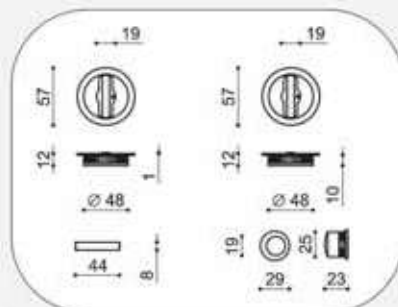

versioni:
art. 82CS: con serratura art. 1690 p. 299
art. 82SS: senza serratura

finiture:
OLV ottone lucido verniciato
SV ottone satinato verniciato
CS ottone cromato satinato
CR ottone cromato lucido
ANT ottone bronzo antico
ORO ottone oro antico
ARG ottone argento antico
RAM ottone ramato antico
BG ottone bronzato graffiato

55Y Kit tondo con foro yale

(B)

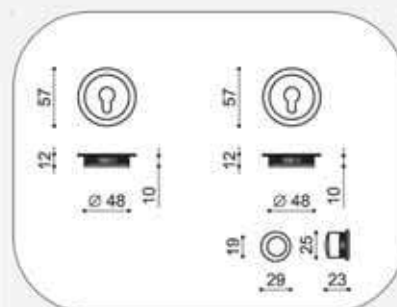

versioni:
art. 55YCS: con serr. art. 1680Y p. 298
art. 55YS: senza serratura

finiture:
OLV ottone lucido verniciato
CS ottone cromato satinato
CR ottone cromato lucido
BG ottone bronzato graffiato

1064 Kit tondo ribassato con pomolino

(B)

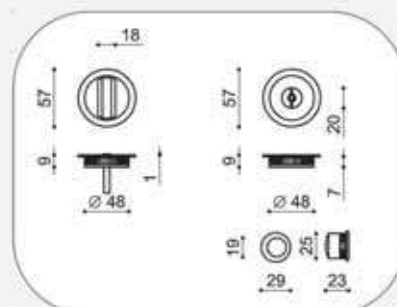

versioni:
art. 1064CS: con serr. art. 1690 p. 29
art. 1064SS: senza serratura
spessore porta standard:
da 35 a 39

soluzione per spessori ridotti

finiture:
OLV ottone lucido verniciato
SV ottone satinato verniciato
CS ottone cromato satinato
CR ottone cromato lucido
BG ottone bronzato graffiato

85

Kit tondo con anello esterno

(B)

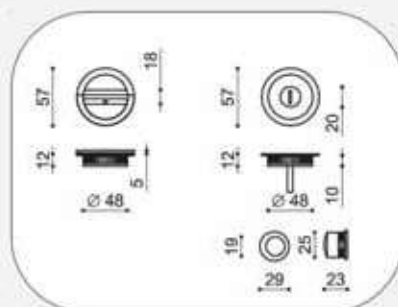

versioni:
 art. 85CS: con serratura art. 1690 p. 299
 art. 85SS: senza serratura
 art. 85SSSD: senza serr. e senza ditale

finiture:
 OLV ottone lucido verniciato
 CS ottone cromato satinato
 CR ottone cromato lucido
 BG ottone bronzato graffiato

86

Kit tondo con due anelli esterni

(B)

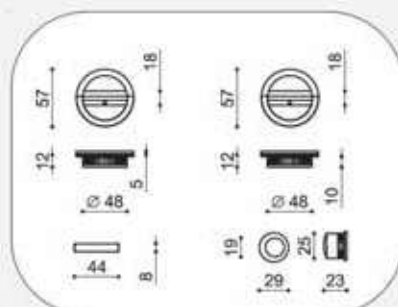

versioni:
 art. 86CS: con serratura art. 1690 p. 299
 art. 86SS: senza serratura
 art. 86SSSD: senza serr. e senza ditale

finiture:
 OLV ottone lucido verniciato
 CS ottone cromato satinato
 CR ottone cromato lucido
 BG ottone bronzato graffiato

85i Kit tondo con anello interno

(B)

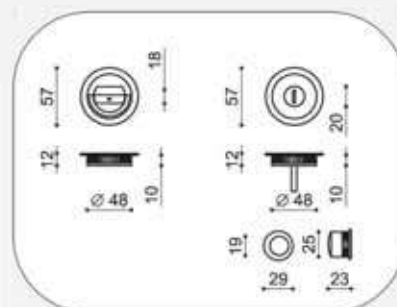

versioni:
 art. 85iCS: con serratura art. 1690 p. 299
 art. 85iSS: senza serratura
 art. 85iSSSD: senza serr. e senza ditale

finiture:
 OLV ottone lucido verniciato
 CS ottone cromato satinato
 CR ottone cromato lucido
 BG ottone bronzato graffiato

86i Kit tondo con due anelli interni

(B)

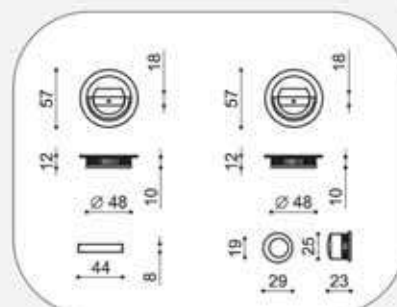

versioni:
 art. 86iCS: con serratura art. 1690 p. 299
 art. 86iSS: senza serratura
 art. 86iSSSD: senza serr. e senza ditale

finiture:
 OLV ottone lucido verniciato
 CS ottone cromato satinato
 CR ottone cromato lucido
 BG ottone bronzato graffiato

1074F

Kit tondo con pom.basso con fin.

ⓑ

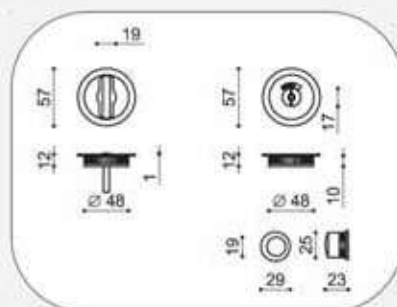

versioni:
art. 1074FCS: con serratura art. 1690 p. 299
art. 1074FSS: senza serratura

finiture:
OLV ottone lucido verniciato
CS ottone cromato satinato
CR ottone cromato lucido
BG ottone bronzato graffiato

1054F

Kit tondo con pom. con finestra

ⓑ

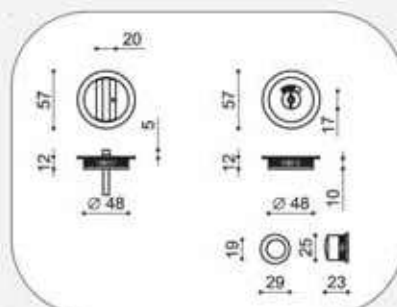

versioni:
art. 1054FCS: con serratura art. 1690 p. 299
art. 1054FSS: senza serratura

finiture:
OLV ottone lucido verniciato
CS ottone cromato satinato
CR ottone cromato lucido
BG ottone bronzato graffiato

85F Kit tondo con anello esterno e finestra [ⓑ]

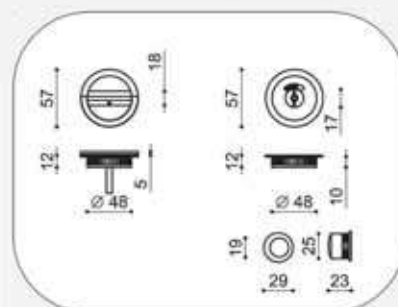

versioni:
 art. 85FCS: con serratura art. 1690 p. 299
 art. 85FSS: senza serratura
 art. 85FSSD: senza serr. e senza ditale

finiture:
 OLV ottone lucido verniciato
 CS ottone cromato satinato
 CR ottone cromato lucido
 BG ottone bronzato graffiato

85iF Kit tondo con anello interno e finestra [ⓑ]

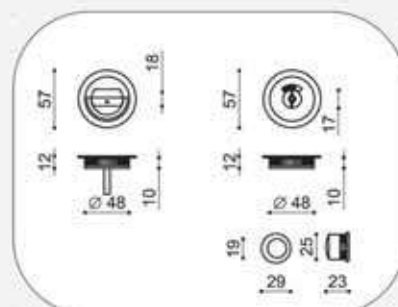

versioni:
 art. 85iFCS: con serratura art. 1690 p. 299
 art. 85iFSS: senza serratura
 art. 85iFSSD: senza serr. e senza ditale

finiture:
 OLV ottone lucido verniciato
 CS ottone cromato satinato
 CR ottone cromato lucido
 BG ottone bronzato graffiato

77

Kit tondo con pendente

(B)

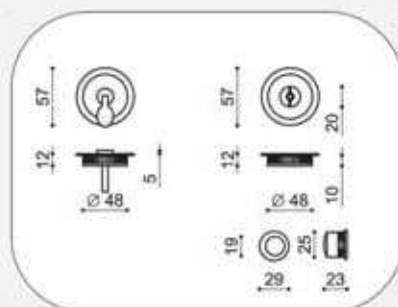

versioni:
 art. 77CS: con serratura art. 1690 p. 299
 art. 77SS: senza serratura

finiture:
 OLV ottone lucido verniciato
 CS ottone cromato satinato
 CR ottone cromato lucido
 BG ottone bronzato graffiato

77B

Kit tondo **ribassato** con pendente

(B)

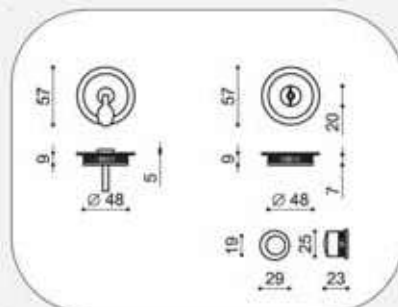

versioni:
 art. 77BCS: con serratura art. 1690 p. 299
 art. 77BSS: senza serratura
spessore porta standard:
 da 35 a 39 mm

soluzione per spessori ridotti

finiture:
 OLV ottone lucido verniciato
 CS ottone cromato satinato
 CR ottone cromato lucido
 BG ottone bronzato graffiato

8532 Kit tondo d. 32 con anello interno

(B)

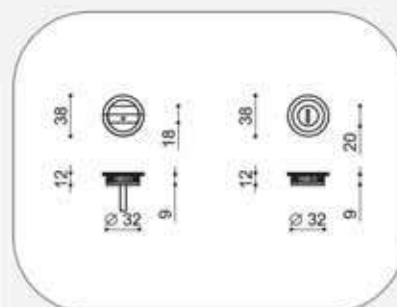

versioni:
 art. 8532CS: con serratura art. 1690 p. 299
 art. 8532SS: senza serratura
spessore porta standard:
 da 38 a 48 mm *tagliando il quadro

finiture:
 OLV ottone lucido verniciato
 CS ottone cromato satinato
 CR ottone cromato lucido

8632 Kit tondo d.32 con due anelli interni

(B)

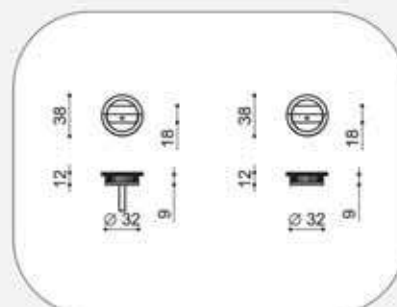

versioni:
 art. 8632CS: con serratura art. 1690 p. 299
 art. 8632SS: senza serratura
spessore porta standard:
 da 38 a 48 mm *tagliando il quadro

finiture:
 OLV ottone lucido verniciato
 CS ottone cromato satinato
 CR ottone cromato lucido

Kit quadri per porte scorrevoli

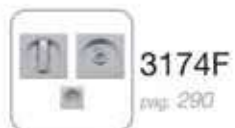

3174 Kit quadro con pomolino basso reg.

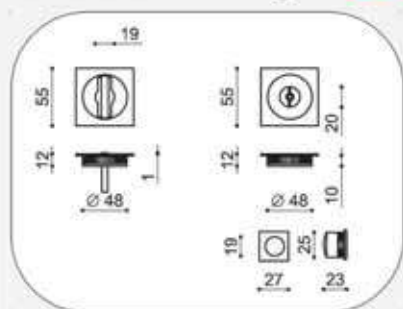

versioni:

3174CS : con serratura art. 1690 pag. 299

3174SS : senza serratura

spessore porta standard:

di serie da 39 a 44 mm

disponibile anche da 44 a 48 mm

su richiesta spessori speciali

finiture:

MORO maritech oro lucido

MCS maritech cromato satinato

MCR maritech cromato lucido

3174F Kit quadro con pom. basso e fin.

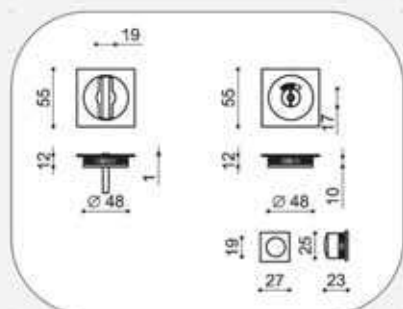

versioni:

3174FCS : con serratura art. 1690 pag. 299

3174FSS : senza serratura

spessore porta standard:

di serie da 39 a 44 mm

disponibile anche da 44 a 48 mm

su richiesta spessori speciali

finiture:

MORO maritech oro lucido

MCS maritech cromato satinato

MCR maritech cromato lucido

3055 Kit quadro con foro chiave

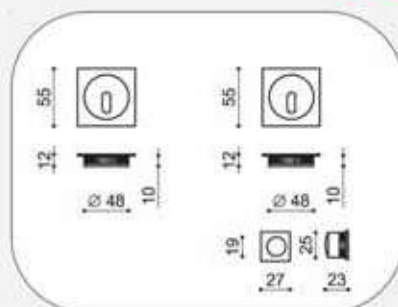

versioni:
art. 3055CS: con serr. art. 1680 p. 298
art. 3055SS: senza serratura

finiture:
MORO maritech oro lucido
MCS maritech cromato satinato
MCR maritech cromato lucido

3056 Kit quadro cieco

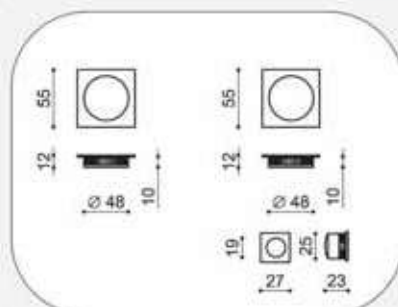

versioni:
art. 3056SS: senza serratura

finiture:
MORO maritech oro lucido
MCS maritech cromato satinato
MCR maritech cromato lucido

3054 Kit quadro con pomolino

3

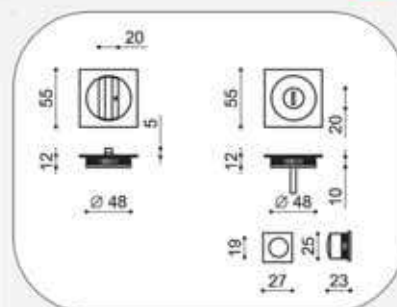

versioni:
3054CS : con serratura art. 1690 pag. 299
3054SS : senza serratura

finiture:
MORO maritech oro lucido
MCS maritech cromato satinato
MCR maritech cromato lucido

3085i Kit quadro con anello interno

3

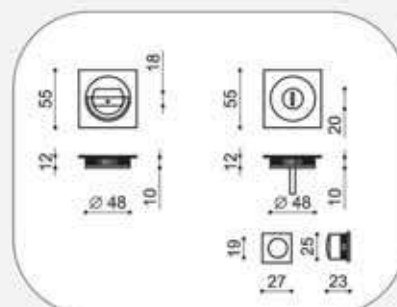

versioni:
3085ICS : con serratura art. 1690 pag. 299
3085ISS : senza serratura

finiture:
MORO maritech oro lucido
MCS maritech cromato satinato
MCR maritech cromato lucido

3085iF

Kit quadro con anello int. e finestra

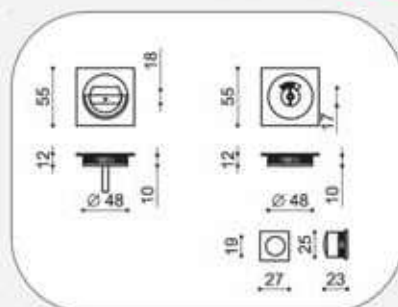

versioni:

3085iFCS : con serratura art. 1690 pag. 299
3085iFSS : senza serratura

finiture:

MORO maritech oro lucido
MCS maritech cromato satinato
MCR maritech cromato lucido

3086i

Kit quadro con due anelli interni

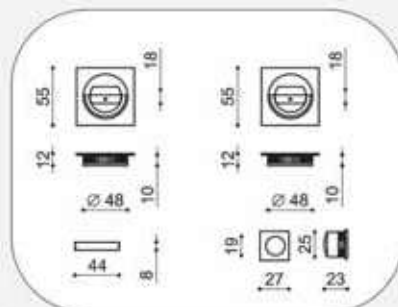

versioni:

3086iCS : con serratura art. 1690 pag. 299
3086iSS : senza serratura

finiture:

MORO maritech oro lucido
MCS maritech cromato satinato
MCR maritech cromato lucido

3085

Kit quadro con anello

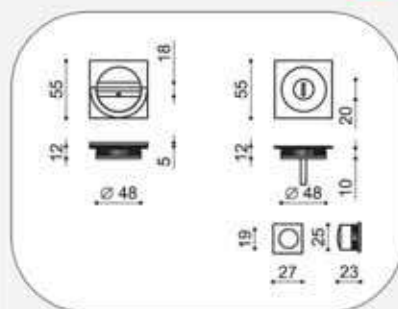

versioni:

3085CS : con serratura art. 1690 pag. 299
3085SS : senza serratura

finiture:

MORO maritech oro lucido
MCS mantech cromato satinato
MCR maritech cromato lucido

3086

Kit quadro con due anelli

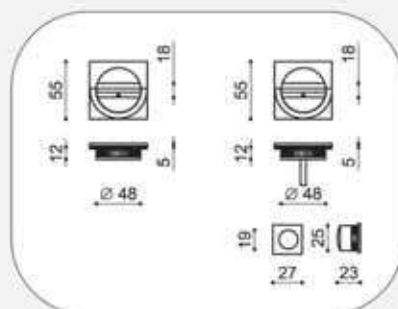

versioni:

3086CS : con serratura art. 1690 pag. 299
3086SS : senza serratura

finiture:

MORO maritech oro lucido
MCS maritech cromato satinato
MCR maritech cromato lucido

3085F

Kit quadro con anello e finestra

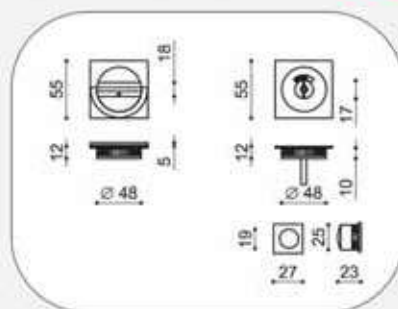

versioni:

3085FCS : con serratura art. 1690 pag. 299
3085FSS : senza serratura

finiture:

MORO maritech oro lucido
MCS maritech cromato satinato
MCR maritech cromato lucido

3055Y

Kit quadro con foro yale

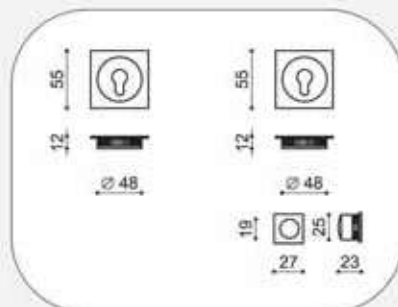

versioni:

3055YCS : con serratura art. 1690 pag. 298
3055YSS : senza serratura

finiture:

MORO maritech oro lucido
MCS maritech cromato satinato
MCR maritech cromato lucido

Accessori per porte scorrevoli



1680
pag. 298



1680Y
pag. 298



1690
pag. 299



1690i
pag. 299



1690iL
pag. 300



1690iC
pag. 300



1680c
pag. 301



1680cc
pag. 301

1680

Serratura con chiave snodata

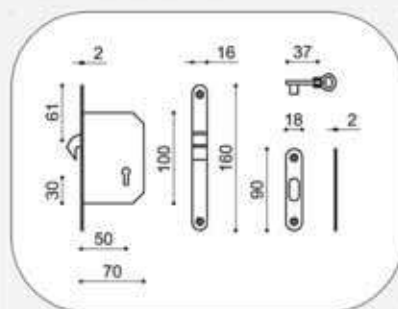

finiture:
FORO oro lucido
FCS cromato satinato
FCR cromato lucido
FBR bronzato

1680Y

Serratura con foro yale

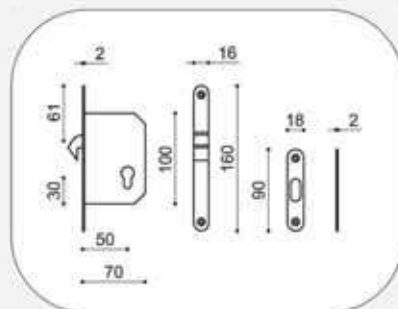

finiture:
FORO oro lucido
FCS cromato satinato

1690

Serratura con quadro

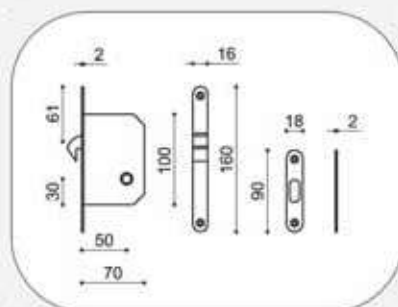

finiture:
FORO oro lucido
FCS cromato satinato
FCR cromato lucido
FBR bronzato

1690i

Incontro per serratura

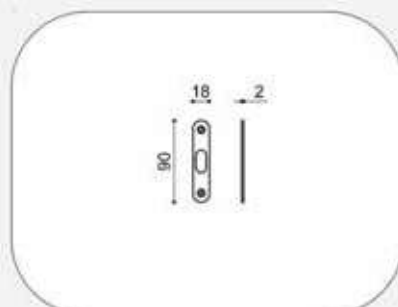

finiture:
FORO oro lucido
FCS cromato satinato
FCR cromato lucido
FBR bronzato

1690iL

Incontro lungo per serratura

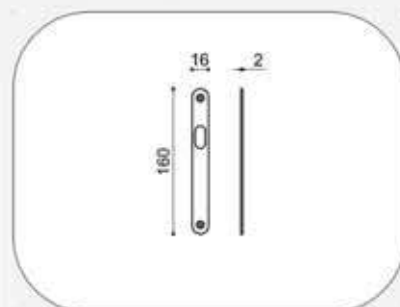

finiture:
FORO oro lucido
FCS cromato satinato

1690iC

Incontro cieco per serratura

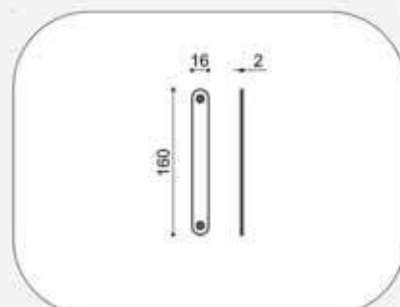

finiture:
FORO oro lucido
FCS cromato satinato

1680c

Chiave snodata per serratura

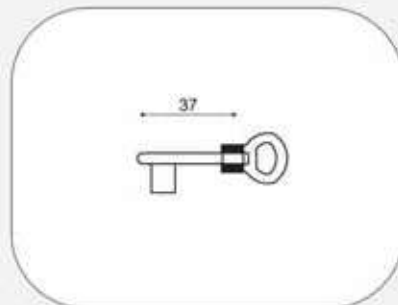

finiture:
FORO oro lucido
FCR cromato lucido
FBR bronzato

1680cc

Chiave snodata per serratura

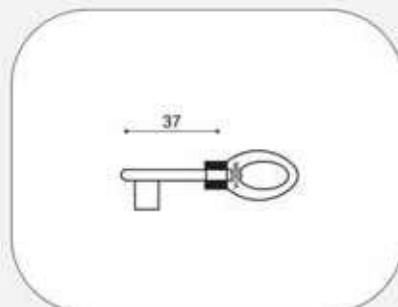

finiture:
FORO oro lucido
FCR cromato lucido
FBR bronzato



57

pag. 304



58

pag. 304

Nicchie per porte scorrevoli



59
pag. 305



90
pag. 305



62
pag. 306



63
pag. 306



5062
pag. 307



5063
pag. 307



64
pag. 308



65
pag. 308



4064
pag. 309



4065
pag. 309



66
pag. 310



67
pag. 310



4059
pag. 311



68
pag. 311



60
pag. 312



60B
pag. 312



2060
pag. 313



908
pag. 313



910
pag. 314



911
pag. 314



905
pag. 315

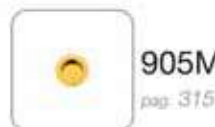

905M
pag. 315



3060
pag. 316



3060B
pag. 316



905Q
pag. 317



908Q
pag. 317



61
pag. 318



61P
pag. 318



2061
pag. 319

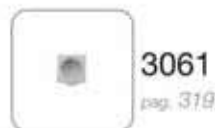

3061
pag. 319

57 Nicchia ovale piena

(B)

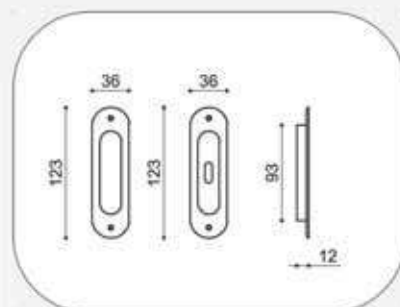

versioni:

57SF : nicchia ovale cieca
57FC : nicchia ovale con foro chiave centrale

finiture:

OLV ottone lucido verniciato
SV ottone satinato verniciato
CS ottone cromato satinato
CR ottone cromato lucido
ANT ottone bronzo antico
BG ottone bronzato graffiato

58 Nicchia ovale esterna

(B)

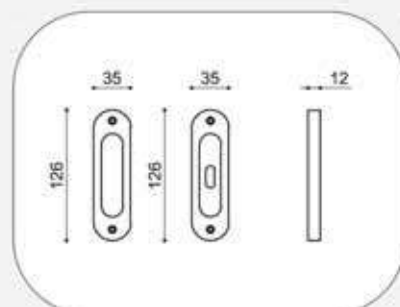

versioni:

58SF : nicchia ovale cieca
58FC : nicchia ovale con foro chiave centrale

finiture:

OLV ottone lucido verniciato
CS ottone cromato satinato
CR ottone cromato lucido
BG ottone bronzato graffiato

59

Nicchia ovale lunga

(B)

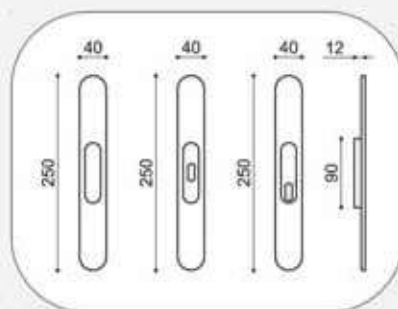

versioni:

- 59SF : nicchia ovale cieca
- 59FC : nicchia ovale con foro chiave centrale
- 59FB : nicchia ovale con foro chiave e basso

finiture:

- OLV ottone lucido verniciato
- SV ottone satinato verniciato
- CS ottone cromato satinato
- CR ottone cromato lucido
- ANT ottone bronzo antico
- BG ottone bronzato graffiato

90

Nicchia ovale leggera

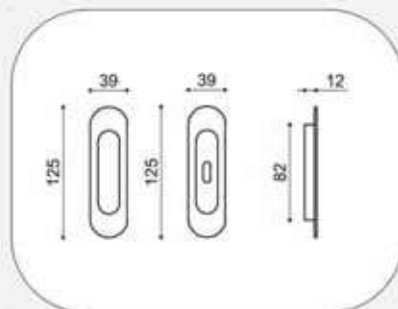

versioni:

- 90SF : nicchia ovale cieca
- 90FC : nicchia ovale con foro chiave centrale

finiture:

- MNO maritech verniciato nero opaco
- MBIA maritech verniciato bianco
- MAVO maritech verniciato avorio
- MSAB maritech verniciato sabbia
- MARG maritech verniciato argento

62

Nicchia ovale con foro chiave

ⓑ

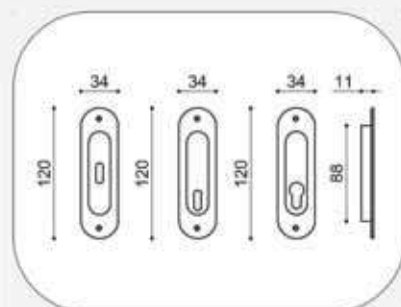

versioni:

- 62FB : nicchia ovale con foro chiave basso
- 62FC : nicchia ovale con foro chiave centrale
- 62FY : nicchia ovale con foro yale

finiture:

- OLV ottone lucido verniciato
- SV ottone satinato verniciato
- NKS ottone nikel satinato
- CS ottone cromato satinato
- CR ottone cromato lucido
- ANT ottone bronzo antico
- ORO ottone oro antico
- ARG ottone argento antico
- RAM ottone ramato antico
- BG ottone bronzato graffiato
- BU ottone bronzo uniforme

63

Nicchia ovale cieca

ⓑ

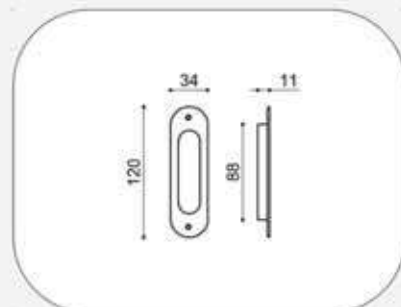

finiture:

- OLV ottone lucido verniciato
- SV ottone satinato verniciato
- NKS ottone nikel satinato
- CS ottone cromato satinato
- CR ottone cromato lucido
- ANT ottone bronzo antico
- ORO ottone oro antico
- ARG ottone argento antico
- RAM ottone ramato antico
- BG ottone bronzato graffiato
- BU ottone bronzo uniforme

5062 Nicchia ovale con foro chiave

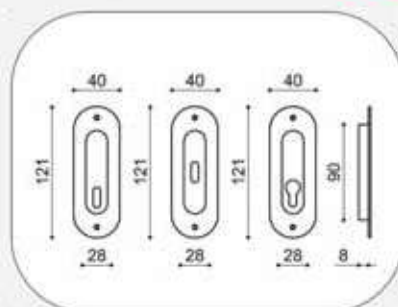

versioni:
5062FB : nicchia ovale con foro basso
5062FC : nicchia ovale con foro centrale
5062FY : nicchia ovale con foro yale

NICCHIA CON GRADINO INTERNO CHE FACILITA LA PRESA

finiture:
MORO maritech oro lucido
MCS maritech cromato satinato

5063 Nicchia ovale cieca

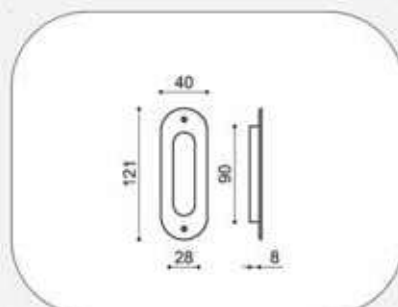

NICCHIA CON GRADINO INTERNO CHE FACILITA LA PRESA

finiture:
MORO maritech oro lucido
MCS maritech cromato satinato

64

Nicchia ovale cieca senza fori

(B)

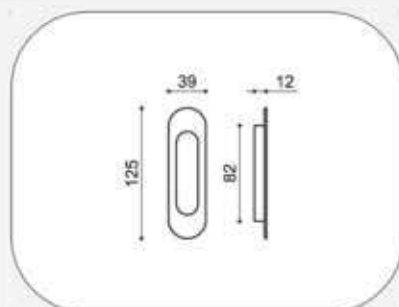

finiture:

OLV	ottone lucido verniciato
SV	ottone satinato verniciato
NKS	ottone nikel satinato
CS	ottone cromato satinato
CR	ottone cromato lucido
ANT	ottone bronzo antico
ORO	ottone oro antico
ARG	ottone argento antico
RAM	ottone ramato antico
BG	ottone bronzato graffiato

65

Nicchia ovale con f/chiave senza fori

(B)

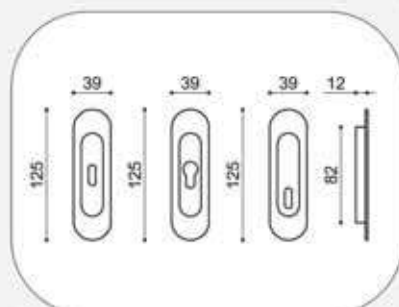

versioni:

65FB	nicchia ovale con foro chiave basso
65FC	nicchia ovale con foro chiave centrale
65FY	nicchia ovale con foro yale

finiture:

OLV	ottone lucido verniciato
SV	ottone satinato verniciato
NKS	ottone nikel satinato
CS	ottone cromato satinato
CR	ottone cromato lucido
ANT	ottone bronzo antico
ORO	ottone oro antico
ARG	ottone argento antico
RAM	ottone ramato antico
BG	ottone bronzato graffiato

4064 Nicchia rett. cieca senza fori

(B)

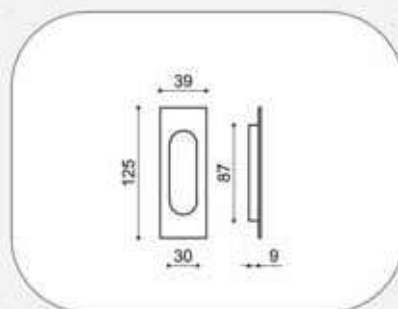

finiture:

- OLV ottone lucido verniciato
- CS ottone cromato satinato
- CR ottone cromato lucido

4065 Nicchia rett. con f./chiave senza fori

(B)

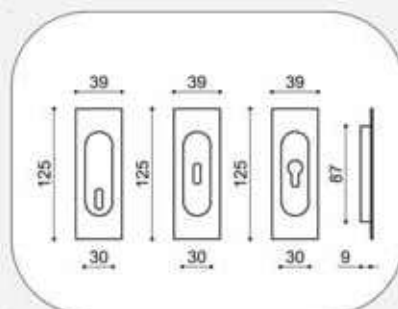

versioni:

- 4065FB : nicchia ovale con foro chiave basso
- 4065FC : nicchia ovale con foro chiave centrale
- 4065FY : nicchia ovale con foro yale

finiture:

- OLV ottone lucido verniciato
- CS ottone cromato satinato
- CR ottone cromato lucido

66

Nicchia ovale cieca

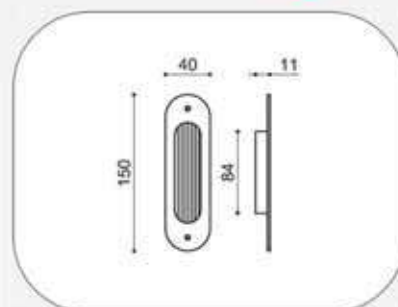

finiture:

- OLV ottone lucido verniciato
- SV ottone satinato verniciato
- CS ottone cromato satinato
- CR ottone cromato lucido
- ANT ottone bronzo antico
- BG ottone bronzato graffiato

- MORO maritech oro lucido
- MCS maritech cromato satinato

67

Nicchia ovale con f/chiave centrale

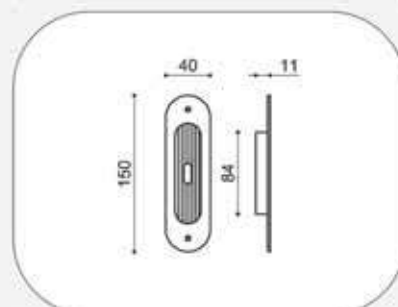

finiture:

- OLV ottone lucido verniciato
- SV ottone satinato verniciato
- CS ottone cromato satinato
- CR ottone cromato lucido
- ANT ottone bronzo antico
- BG ottone bronzato graffiato

- MORO maritech oro lucido
- MCS maritech cromato satinato

4059 Nicchia rettangolare lunga cieca

Ⓑ

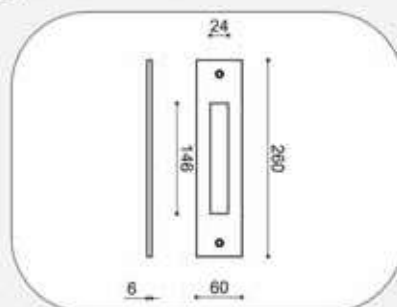

SISTEMA SENZA FRESATA

finiture:
CS ottone cromato satinato
CR ottone cromato lucido

68 Nicchia rettangolare cieca

Ⓑ

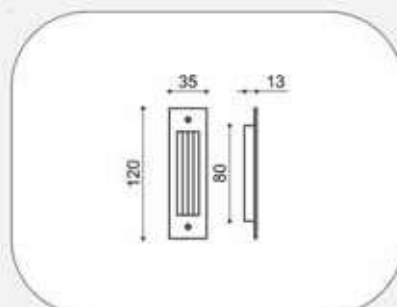

finiture:
OLV ottone lucido verniciato
CS ottone cromato satinato

60 Nicchia tonda

Ⓑ

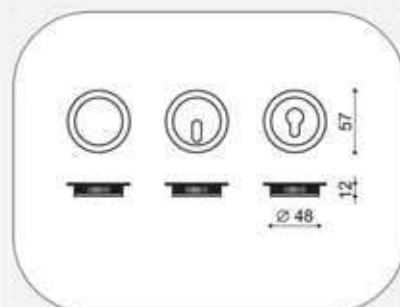

versioni:

- 60SF : nicchia tonda cieca
- 60FC : nicchia tonda con foro chiave
- 60FY : nicchia tonda con foro yale

finiture:

- OLV ottone lucido verniciato
- SV ottone satinato verniciato
- NKS ottone nikel satinato
- CS ottone cromato satinato
- CR ottone cromato lucido
- ANT ottone bronzo antico
- ORO ottone oro antico
- ARG ottone argento antico
- RAM ottone ramato antico
- BG ottone bronzato graffiato
- BU ottone bronzo uniforme

60B Nicchia tonda bassa

Ⓑ

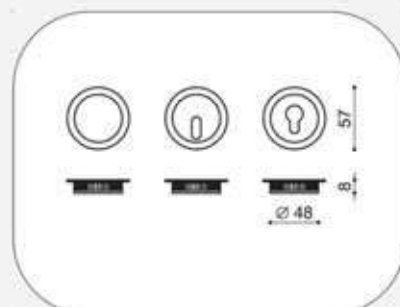

versioni:

- 60BSF : nicchia tonda bassa cieca
- 60BFC : nicchia tonda bassa con foro chiave
- 60BFY : nicchia tonda bassa con foro yale

finiture:

- OLV ottone lucido verniciato
- SV ottone satinato verniciato
- NKS ottone nikel satinato
- CS ottone cromato satinato
- CR ottone cromato lucido
- ANT ottone bronzo antico
- ORO ottone oro antico
- ARG ottone argento antico
- RAM ottone ramato antico
- BG ottone bronzato graffiato
- BU ottone bronzo uniforme

2060 Nicchia tonda

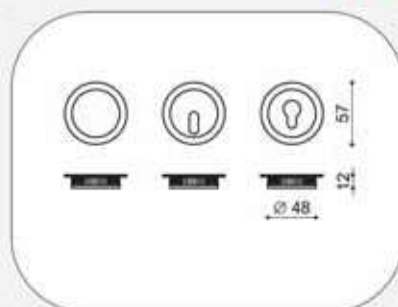

versioni:
2060SF : nicchia tonda cieca
2060FC : nicchia tonda con foro chiave
2060FY : nicchia tonda con foro yale

finiture:
MPVD maritech con trattamento PVD

MORO maritech oro lucido
MCS maritech cromato satinato
MCR maritech cromato lucido

908 Nicchia tonda mezza luna

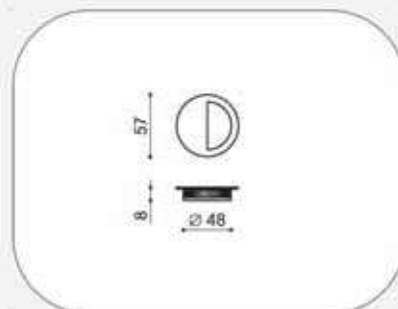

finiture:
OLV ottone lucido verniciato
CS ottone cromato satinato
CR ottone cromato lucido
BG ottone bronzato graffiato

910 Nicchia tonda con bordo largo

Ⓑ

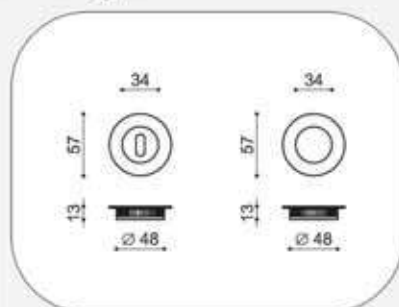
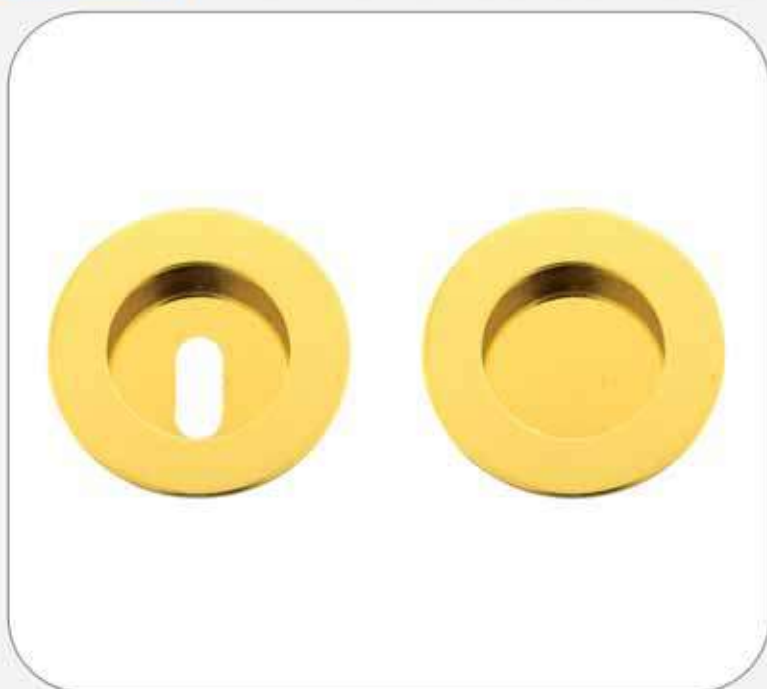

versioni:

- 910SF : nicchia tonda cieca
- 910FC : nicchia tonda con foro chiave
- 910FY : nicchia tonda con foro yale

finiture:

- OLV ottone lucido verniciato
- SV ottone satinato verniciato
- CS ottone cromato satinato
- CR ottone cromato lucido
- BG ottone bronzato graffiato

911 Nicchia tonda con bordo largo

Ⓜ

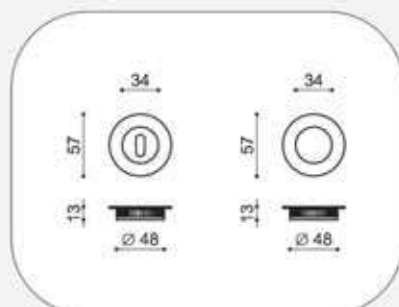
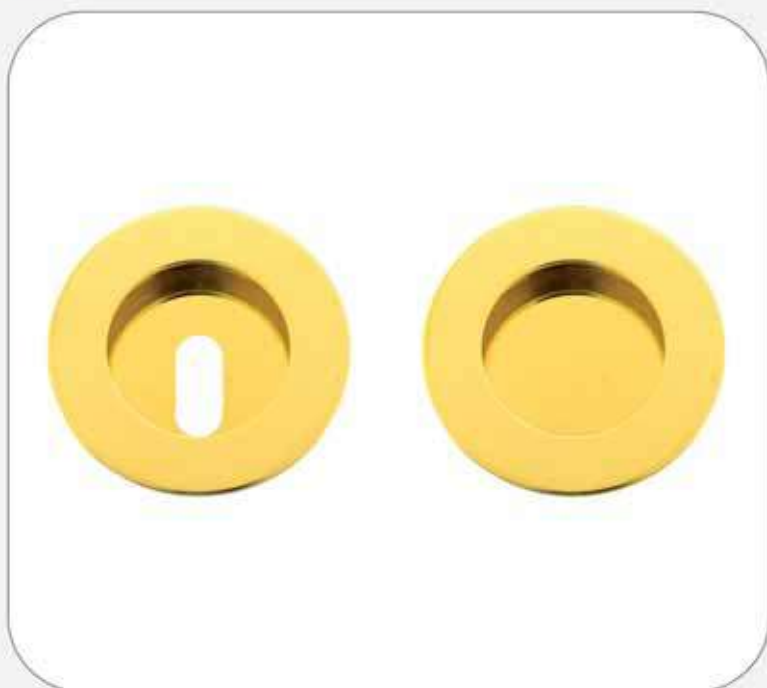

versioni:

- 911SF : nicchia tonda cieca
- 911FC : nicchia tonda con foro chiave
- 911FY : nicchia tonda con foro yale

finiture:

- MORO maritech oro lucido
- MCS maritech cromato satinato

905 Nicchia tonda

(B)

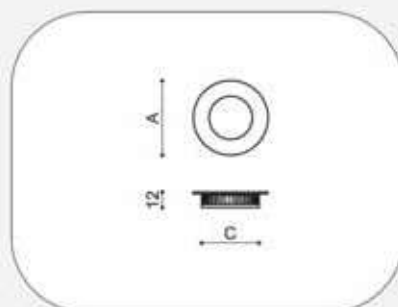

versioni:

905 25 : A d. 30 mm - C incasso d. 25
905 30 : A d. 35 mm - C incasso d. 30
905 35 : A d. 40 mm - C incasso d. 35
905 40 : A d. 45 mm - C incasso d. 40

905R 35 : versione ribassata 10 mm

finiture:

OLV ottone lucido verniciato
NKS ottone nikel satinato
CS ottone cromato satinato
CR ottone cromato lucido
ANT ottone bronzo antico
BG ottone bronzato graffiato
BU ottone bronzo uniforme

905M Nicchia tonda

(S)

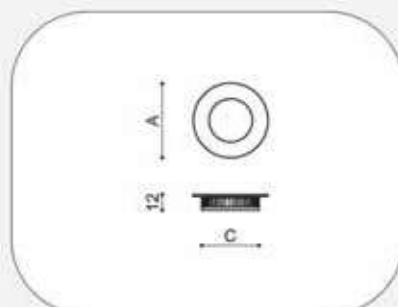

versioni:

905M 35 : A d. 40 mm - C incasso d. 35
905M 40 : A d. 45 mm - C incasso d. 40

finiture:

MORO maritech oro lucido
MCS maritech cromato satinato
MCR maritech cromato lucido

3060 Nicchia quadra

3

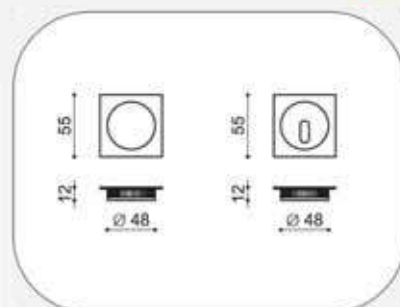

versioni:
3060SF : nicchia quadra cieca
3060FC : nicchia quadra con foro chiave

finiture:
MORO maritech oro lucido
MCS maritech cromato satinato
MCR maritech cromato lucido

3060B Nicchia quadra bassa

B

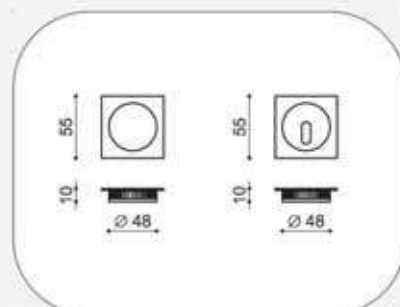

versioni:
3060BSF : nicchia quadra bassa cieca
3060BFC : nicchia quadra bassa con foro chiave

finiture:
OLV ottone lucido verniciato
NKS ottone nikel satinato
CS ottone cromato satinato
CR ottone cromato lucido

905Q Nicchia quadra

3

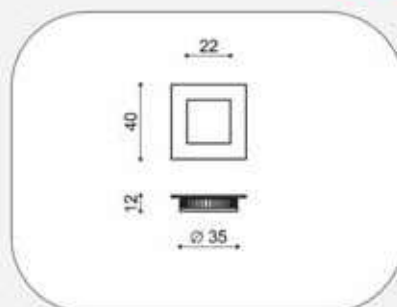

finiture:

MCS maritech cromato satinato
MCR maritech cromato lucido

908Q Nicchia quadra mezzaluna

B

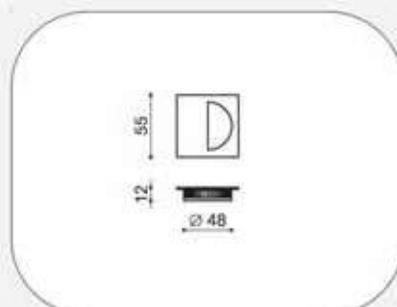

finiture:

OLV ottone lucido verniciato
CS ottone cromato satinato
CR ottone cromato lucido

61 **Ditale di trascinamento**

ⓑ

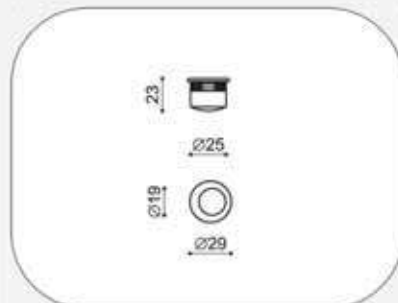

ditale in ottone con tappino in plastica

finiture:

OLV	ottone lucido verniciato
SV	ottone satinato verniciato
NKS	ottone nikel satinato
CS	ottone cromato satinato
CR	ottone cromato lucido
ANT	ottone bronzo antico
ORO	ottone oro antico
ARG	ottone argento antico
RAM	ottone ramato antico
BG	ottone bronzato graffiato
BU	ottone bronzo uniforme

61P **Ditale di trascinamento**

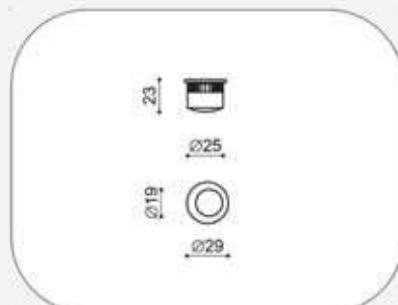

ditale in plastica con ghiera in metallo

finiture:

OLV	lucido verniciato
NKS	nikel satinato
CS	cromato satinato
CR	cromato lucido
BG	bronzato graffiato

2061 ditale di trascinamento

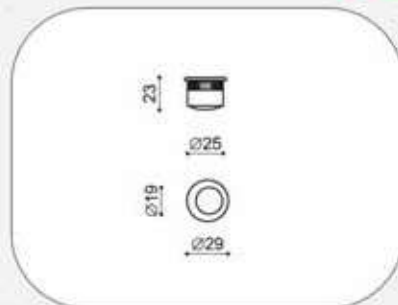

finiture:

- MORO** maritech oro lucido
- MCS** maritech cromato satinato
- MCR** maritech cromato lucido

3061 Ditale di trascinamento quadro

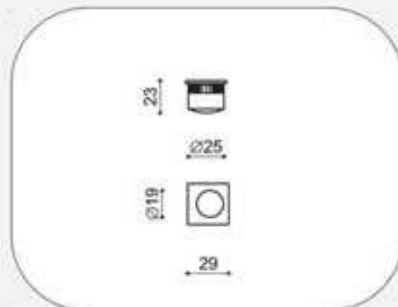

finiture:

- MORO** maritech oro lucido
- MCS** maritech cromato satinato
- MCR** maritech cromato lucido

Nottolino WC



1705

pag. 322



1706

pag. 322



1707

pag. 323



1708

pag. 323



1709

pag. 324



1710

pag. 324



1711

pag. 325



1712

pag. 325



1713

pag. 326



1714

pag. 328



1715

pag. 327



1716

pag. 327



1717

pag. 328



1718

pag. 328



1719

pag. 329



1721

pag. 329



1735

pag. 330



1736

pag. 330



1740

pag. 331



1741

pag. 331



1746

pag. 332



1747

pag. 332



1748

pag. 333



1749

pag. 333

1705 Wc quadro con pomolino quadrato

(B)

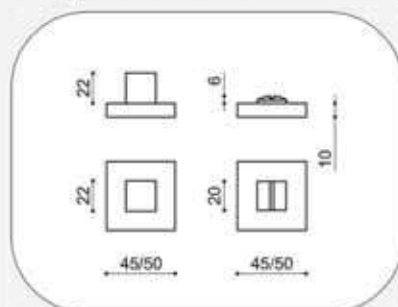

versioni:

1705RQ45: rosetta quadra mm 45x45

1705RQ50: rosetta quadra mm 50x50

spessore standard fino a 50 mm

spessori maggiori su richiesta

finiture:

CS ottone cromato satinato

CR ottone cromato lucido

CR/CS ottone bicolore cromo/satinato

1706 Wc quadro con pom. rettangolare

(S)

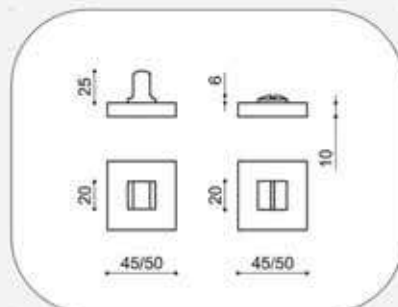

versioni:

1706RQ45: rosetta quadra mm 45x45

1706RQ50: rosetta quadra mm 50x50

spessore standard fino a 50 mm

spessori maggiori su richiesta

finiture:

MCS maritech cromato satinato

MCR maritech cromato lucido

MCR/CS bi colore cromo lucido / satinato

1707 Wc quadro con pom. rettangolare

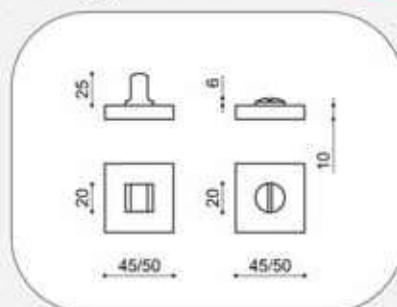

versioni:
 1707RQ45: rosetta quadra mm 45x45
 1707RQ50: rosetta quadra mm 50x50
spessore standard fino a 50 mm
 spessori maggiori su richiesta

finiture:
MCS maritech cromato satinato
MCR maritech cromato lucido
MCR/CS maritech bicolore cromo/sat.
MNO maritech verniciato nero opaco
MBIA maritech verniciato bianco
MAVO maritech verniciato avorio
MSAB maritech verniciato sabbia

1708 Wc quadro con pomolino alto

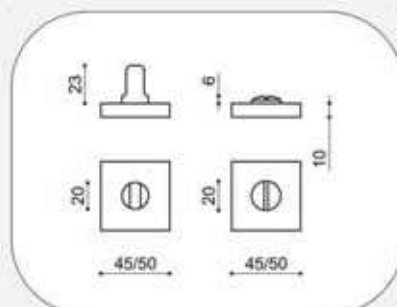

versioni:
 1708RQ45: rosetta quadra mm 45x45
 1708RQ50: rosetta quadra mm 50x50
spessore standard fino a 50 mm
 spessori maggiori su richiesta

finiture:
MCS maritech cromato satinato
MCR maritech cromato lucido
MCR/CS maritech bicolore cromo/sat.
MNO maritech verniciato nero opaco
MBIA maritech verniciato bianco
MAVO maritech verniciato avorio
MSAB maritech verniciato sabbia

1709 Wc rettangolare con pom. quadro

(B)

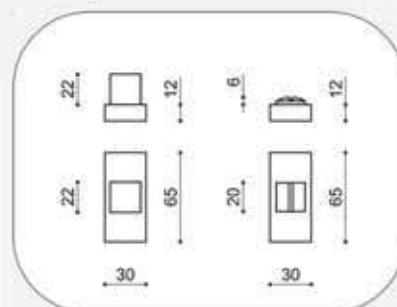

spessore standard fino a 50 mm
spessori maggiori su richiesta

finiture:
CS ottone cromato satinato
CR ottone cromato lucido
CR/CS ottone bicolore cromo/satinato

1710 Wc rettangolare con pom. rett.

(S)

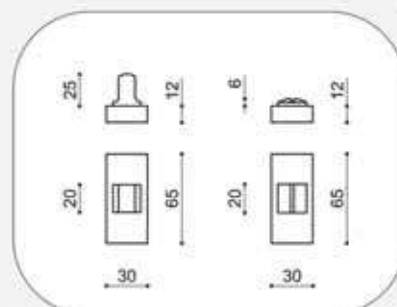

spessore standard fino a 50 mm
spessori maggiori su richiesta

finiture:
MCS maritech cromato satinato
MCR maritech cromato lucido
MCR/CS bi colore cromo lucido / satinato

1711 Wc rettangolare con pom. rett.

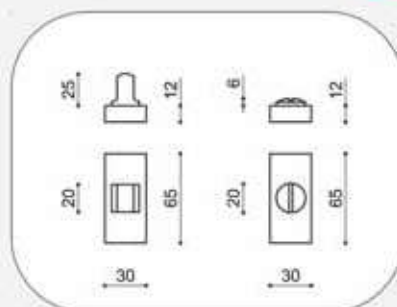

spessore standard fino a 50 mm
spessori maggiori su richiesta

finiture:
MCS maritech cromato satinato
MCR maritech cromato lucido
MCR/CS bi colore: cromo lucido / satinato

1712 Wc rettangolare con pom. alto

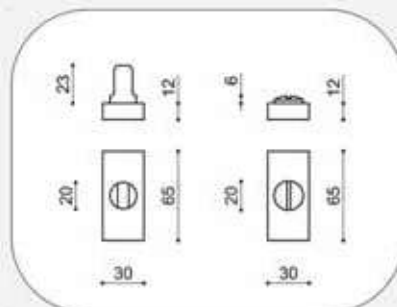

spessore standard fino a 50 mm
spessori maggiori su richiesta

finiture:
MCS maritech cromato satinato
MCR maritech cromato lucido
MCR/CS bi colore: cromo lucido / satinato

1713 Wc ovale con pomolino alto

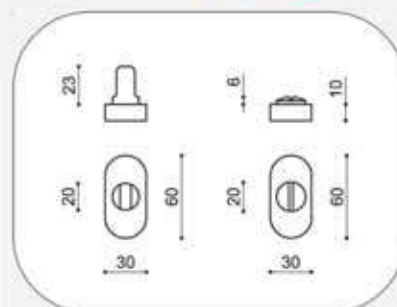

spessore standard fino a 50 mm
spessori maggiori su richiesta

finiture:

PVD ottone con trattamento PVD

OLV ottone lucido verniciato
SV ottone satinato verniciato
CS ottone cromato satinato
CR ottone cromato lucido
ANT ottone bronzo antico
ORO ottone oro antico
ARG ottone argento antico
RAM ottone ramato antico
BG ottone bronzato graffiato

MORO maritech oro lucido
MCS maritech cromato satinato
MCR maritech cromato lucido

1714 Wc ovale con pom. a farfalla

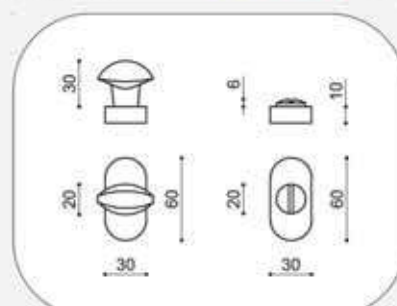

spessore standard fino a 50 mm
spessori maggiori su richiesta

finiture:

PVD ottone con trattamento PVD

OLV ottone lucido verniciato
SV ottone satinato verniciato
CS ottone cromato satinato
CR ottone cromato lucido
BG ottone bronzato graffiato

MORO maritech oro lucido
MCS maritech cromato satinato
MCR maritech cromato lucido

1715 Wc bombato con pomolino alto

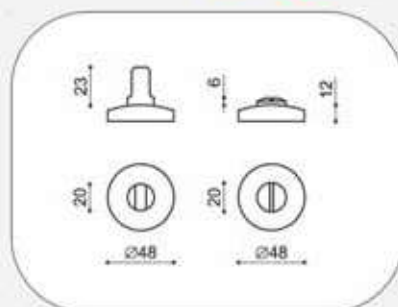

spessore standard fino a 50 mm
spessori maggiori su richiesta

finiture:

PVD ottone con trattamento PVD

OLV ottone lucido verniciato
SV ottone satinato verniciato
CS ottone cromato satinato
CR ottone cromato lucido
ANT ottone bronzo antico
ORO ottone oro antico
ARG ottone argento antico
RAM ottone ramato antico
BG ottone bronzato graffiato

MORO maritech oro lucido

MCS maritech cromato satinato

MCR maritech cromato lucido

1716 Wc bombato con pom. a farfalla

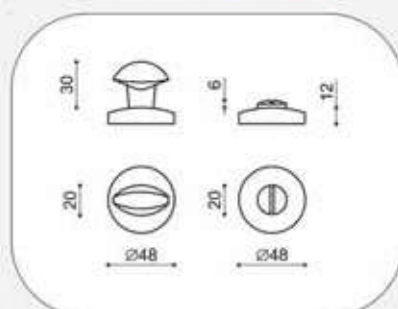

spessore standard fino a 50 mm
spessori maggiori su richiesta

finiture:

PVD ottone con trattamento PVD

OLV ottone lucido verniciato
SV ottone satinato verniciato
CS ottone cromato satinato
CR ottone cromato lucido
BG ottone bronzato graffiato

MORO maritech oro lucido

MCS maritech cromato satinato

MCR maritech cromato lucido

1717 Wc tondo con pom. quadrato

ⓑ

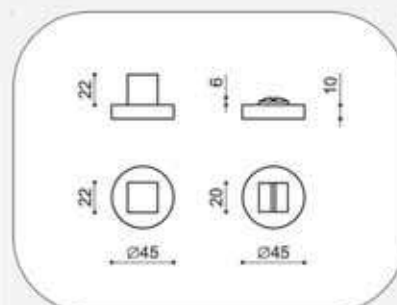

spessore standard fino a 50 mm
spessori maggiori su richiesta

finiture:
CS ottone cromato satinato
CR ottone cromato lucido
CR/CS ottone bi colore cromo / satinato

1718 Wc tondo con pom. rettangolare

Ⓜ ⓑ

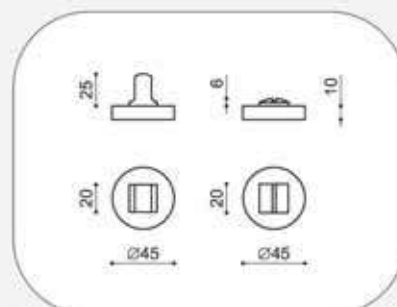

spessore standard fino a 50 mm
spessori maggiori su richiesta

finiture:
CS ottone cromato satinato
CR ottone cromato lucido
CR/CS ottone bi colore cromo / satinato

MCS maritech cromato satinato
MCR maritech cromato lucido
MCR/CS maritech bi colore cromo / satinato

1719 Wc tondo con pom. rettangolare

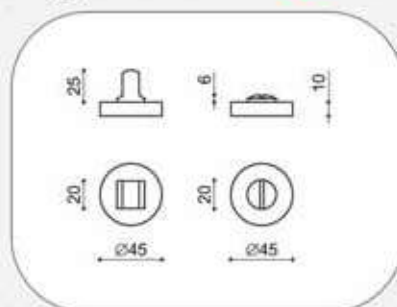

spessore standard fino a 50 mm
spessori maggiori su richiesta

finiture:
CS ottone cromato satinato
CR ottone cromato lucido
CR/CS ottone bi colore cromo / satinato

MCS maritech cromato satinato
MCR maritech cromato lucido
MCR/CS maritech bi colore cromo / satinato

1721 Wc tondo con pomolino alto

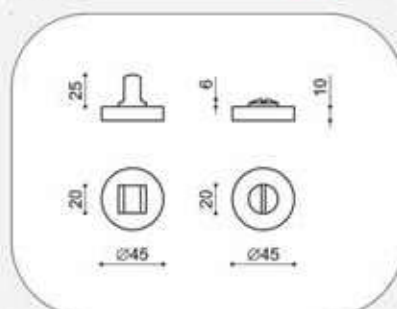

spessore standard fino a 50 mm
spessori maggiori su richiesta

finiture:
OLV ottone lucido verniciato
SV ottone satinato verniciato
CS ottone cromato satinato
CR ottone cromato lucido
BG ottone bronzato graffiato

MORO maritech oro lucido
MCS maritech cromato satinato
MCR maritech cromato lucido

1735 Wc tondo con pom. a farfalla

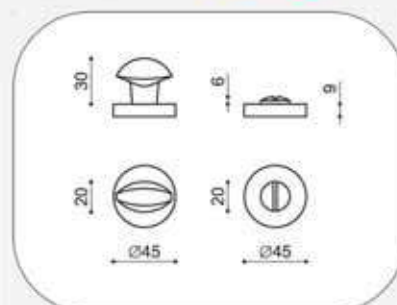

versioni:
 1735R45 : rosetta diametro 45 mm
 1735R48 : rosetta diametro 48 mm
 1735R50 : rosetta diametro 50 mm
 spessore standard fino a 50 mm
 spessori maggiori su richiesta

finiture:
 PVD ottone con trattamento PVD
 OLV ottone lucido verniciato
 SV ottone satinato verniciato
 CS ottone cromato satinato
 CR ottone cromato lucido
 ANT ottone bronzo antico
 ORO ottone oro antico
 ARG ottone argento antico
 RAM ottone ramato antico
 BG ottone bronzato graffiato
 MORO maritech oro lucido
 MCS maritech cromato satinato
 MCR maritech cromato lucido

1736 Wc tondo con fin. e pom. a farf.

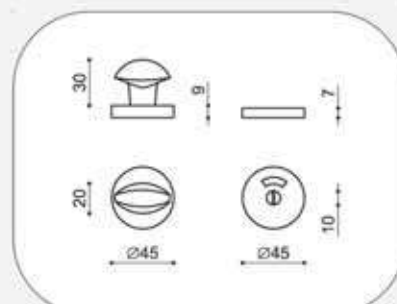

spessore standard fino a 50 mm
 spessori maggiori su richiesta

finiture:
 PVD ottone con trattamento PVD
 OLV ottone lucido verniciato
 CS ottone cromato satinato
 CR ottone cromato lucido
 ANT ottone bronzo antico
 ORO ottone oro antico
 ARG ottone argento antico
 RAM ottone ramato antico
 BG ottone bronzato graffiato
 MORO maritech oro lucido
 MCS maritech cromato satinato
 MCR maritech cromato lucido

1740 Wc tondo con pomolino alto

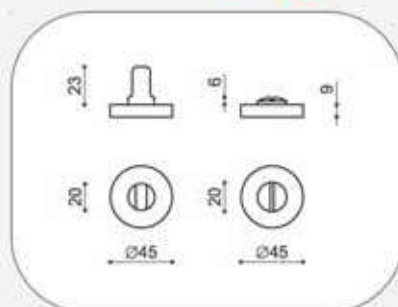

versioni:
 1740R45 : rosetta diametro 45 mm
 1740R48 : rosetta diametro 48 mm
 1740R50 : rosetta diametro 50 mm
 spessore standard fino a 50 mm
 spessori maggiori su richiesta

- finiture:
- PVD ottone con trattamento PVD
 - OLV ottone lucido verniciato
 - SV ottone satinato verniciato
 - CS ottone cromato satinato
 - CR ottone cromato lucido
 - ANT ottone bronzo antico
 - ORO ottone oro antico
 - ARG ottone argento antico
 - RAM ottone ramato antico
 - BG ottone bronzato graffiato
 - MORO maritech oro lucido
 - MCS maritech cromato satinato
 - MCR maritech cromato lucido

1741 Wc tondo con fin. e pom. alto

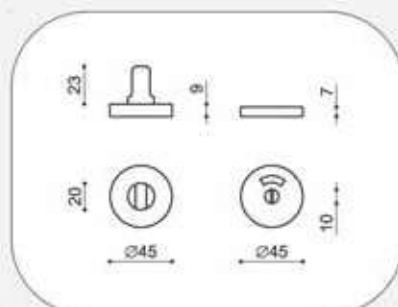

spessore standard fino a 50 mm
 spessori maggiori su richiesta

- finiture:
- PVD ottone con trattamento PVD
 - OLV ottone lucido verniciato
 - CS ottone cromato satinato
 - CR ottone cromato lucido
 - ANT ottone bronzo antico
 - ORO ottone oro antico
 - ARG ottone argento antico
 - RAM ottone ramato antico
 - BG ottone bronzato graffiato
 - MORO maritech oro lucido
 - MCS maritech cromato satinato
 - MCR maritech cromato lucido

1746 Pomolino wc rettangolare + tcq

(B)

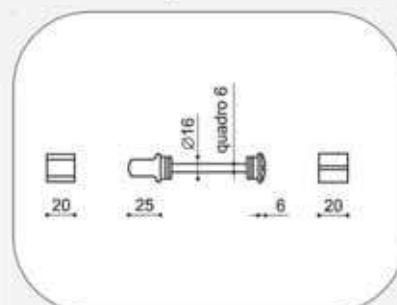

spessore standard fino a 50 mm
spessori maggiori su richiesta

finiture:
CS ottone cromato satinato
CR ottone cromato lucido

1747 Pomolino wc rettangolare + tct

(M) (B)

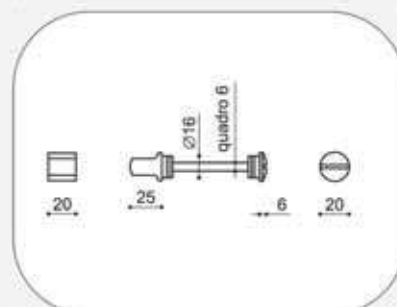

spessore standard fino a 50 mm
spessori maggiori su richiesta

finiture:
CS ottone cromato satinato
CR ottone cromato lucido

MCS maritech cromato satinato
MCR maritech cromato lucido



Coordinati



570
pag. 341



200E
pag. 341



720
pag. 342



730
pag. 342



1101
pag. 343



1103
pag. 343



510
pag. 344



515
pag. 344



530
pag. 345



535
pag. 345



700
pag. 346



705
pag. 346



710
pag. 347



106
pag. 347



101
pag. 348



102
pag. 348



104
pag. 349



105
pag. 349



165R45
pag. 350



165RO
pag. 350



156R45
pag. 351



156RO
pag. 351



160MRO
pag. 352



70MRO
pag. 352



3109
pag. 353



3110
pag. 353



128
pag. 354



129
pag. 354



132
pag. 355



133
pag. 355

325 Fermaporta onda

(B)

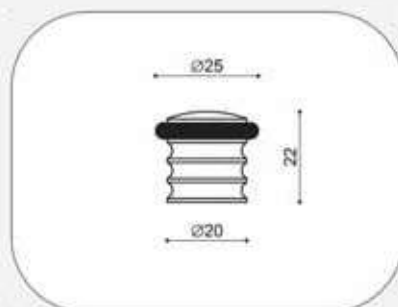

completo di fischer e vite a mordente

finiture:

OLV	ottone lucido verniciato
SV	ottone satinato verniciato
CS	ottone cromato satinato
CR	ottone cromato lucido
BG	ottone bronzato graffiato
BV	ottone bronzato verniciato

330 Fermaporta sfera

(B)

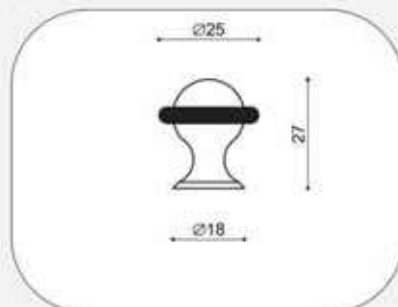

completo di fischer e vite a mordente

finiture:

OLV	ottone lucido verniciato
SV	ottone satinato verniciato
CS	ottone cromato satinato
CR	ottone cromato lucido
NKS	ottone nikel satinato
ANT	ottone bronzo antico
ORO	ottone oro antico
ARG	ottone argento antico
RAM	ottone ramato antico
BG	ottone bronzato graffiato
BV	ottone bronzato verniciato

335 Fermaporta chiocciola

(B)

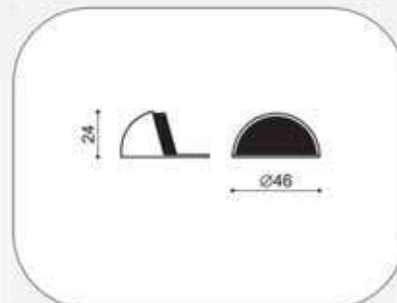

completo di fischer e vite

finiture:

OLV	ottone lucido verniciato
CS	ottone cromato satinato
CR	ottone cromato lucido
BG	ottone bronzato graffiato
BV	ottone bronzato verniciato

340 Fermaporta cilindro

(B)

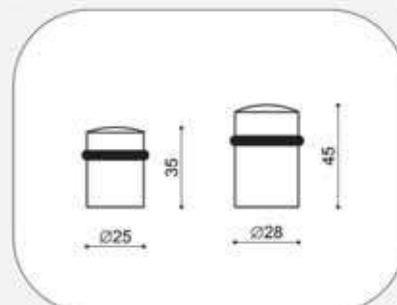

versioni:

34025 : diametro mm 25
34028 : diametro mm 28

completo di fischer e vite a mordente

finiture:

OLV	ottone lucido verniciato
SV	ottone satinato verniciato
CS	ottone cromato satinato
CR	ottone cromato lucido
NKS	ottone nikel satinato
BG	ottone bronzato graffiato
BV	ottone bronzato verniciato

540 Catenaccio orizzontale

(B)

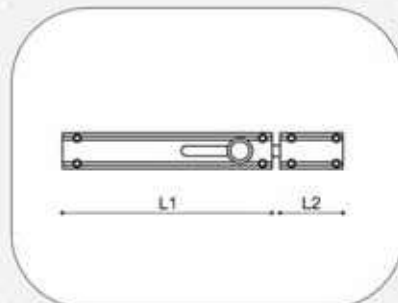

versioni:

540150 : L1 120 + L2 30 = 150 mm
 540200 : L1 150 + L2 50 = 150 mm
 540250 : L1 190 + L2 60 = 150 mm
 540300 : L1 220 + L2 80 = 150 mm

finiture:

OLV ottone lucido verniciato
 CS ottone cromato satinato
 CR ottone cromato lucido
 BG ottone bronzato graffiato

545 Catenaccio verticale

(B)

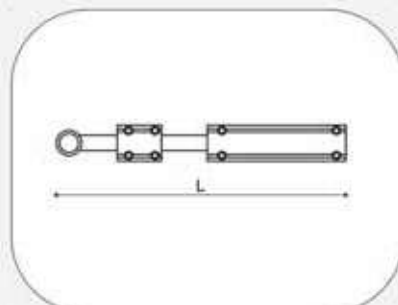

versioni:

545200 : lunghezza totale 200 mm
 545250 : lunghezza totale 250 mm
 545300 : lunghezza totale 300 mm

incontri:

545A : incontro tipo A
 545B : incontro tipo B

finiture:

OLV ottone lucido verniciato
 CS ottone cromato satinato
 CR ottone cromato lucido
 BG ottone bronzato graffiato

550 Catenaccio

(B)

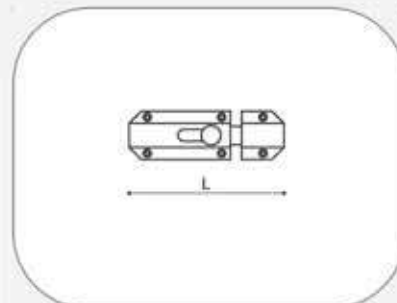

versioni:
55050 : L 50 mm
55075 : L 75 mm
550100 : L 100 mm
550125 : L 125 mm
550150 : L 150 mm
550200 : L 200 mm

finiture:
OLV ottone lucido verniciato

555 Catenaccio

(B)

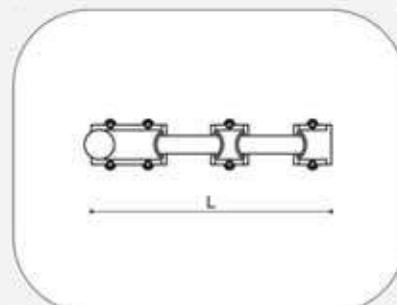

versioni:
555100 : L 100 mm
555150 : L 150 mm
555200 : L 200 mm
555250 : L 250 mm
555300 : L 300 mm

finiture:
OLV ottone lucido verniciato

560 Catenaccio

Ⓑ

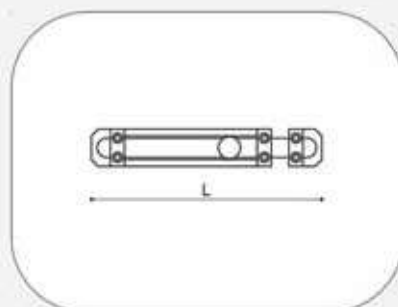

versioni:
560120 : L 120 mm
560150 : L 150 mm
560200 : L 200 mm
560250 : L 250 mm
560300 : L 300 mm

finiture:
OLV ottone lucido verniciato

565 Catenaccio

Ⓑ

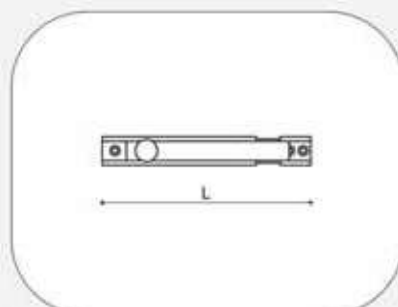

versioni:
56560 : L 60 mm
56575 : L 75 mm
565100 : L 100 mm
565120 : L 120 mm
565150 : L 150 mm

finiture:
OLV ottone lucido verniciato

570 Catenaccio

Ⓑ

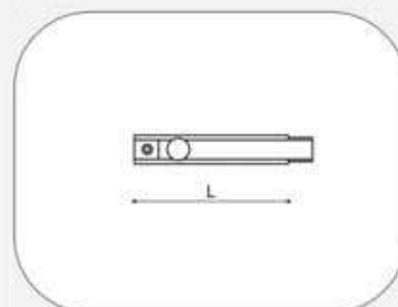

versioni:
57075 : L 75 mm
570100 : L 100 mm
570125 : L 125 mm
570150 : L 150 mm

finiture:
OLV : ottone lucido verniciato

200E Cerniera a scomparsa

Ⓑ

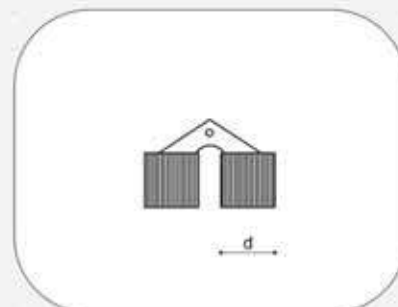

versioni:
E20010 : diametro 10 mm
E20012 : diametro 12 mm
E20014 : diametro 14 mm
E20016 : diametro 16 mm
E20018 : diametro 18 mm
E20024 : diametro 24 mm

finiture:
OL : ottone lucido

720 Bucalettera

Ⓑ

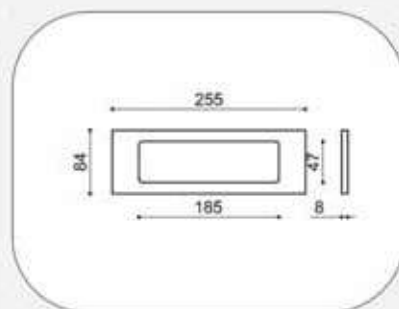

finiture:

- OLV ottone lucido verniciato
- CS ottone cromato satinato
- CR ottone cromato lucido
- BG ottone bronzato graffiato

730 Bucalettera

Ⓑ

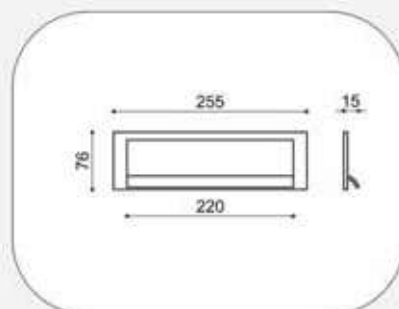

finiture:

- OLV ottone lucido verniciato
- CS ottone cromato satinato
- CR ottone cromato lucido
- BG ottone bronzato graffiato

1101 Numero mm 50 con pioli

Ⓑ



finiture:
OLV ottone lucido verniciato
VARG ottone verniciato argento

1103 Numero mm100 con chiodi fil. M5

Ⓑ



finiture:
OLV ottone lucido verniciato
VARG ottone verniciato argento

530 Coprinterruttore tondo

Ⓑ

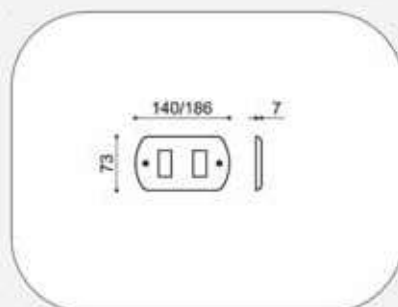

numero fori disponibili: 1-2-3

finiture:

OLV ottone lucido verniciato
SV ottone satinato verniciato
CS ottone cromato satinato
CR ottone cromato lucido
BG ottone bronzato graffiato

535 Copriavvolgibile tondo

Ⓑ

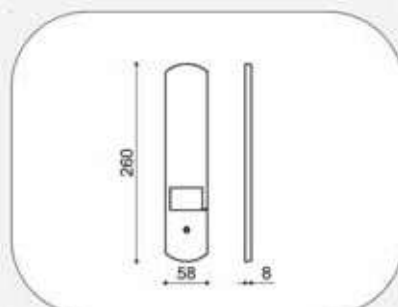

finiture:

OLV ottone lucido verniciato
SV ottone satinato verniciato
CS ottone cromato satinato
CR ottone cromato lucido
BG ottone bronzato graffiato

700 Guidacinghie quadro

(B)

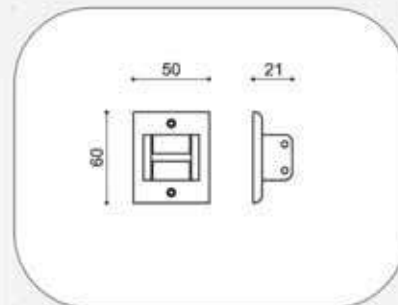

finiture:
OLV ottone lucido verniciato
CS ottone cromato satinato
CR ottone cromato lucido
BG ottone bronzato graffiato

705 Guidacinghie ovale traverso

(B)

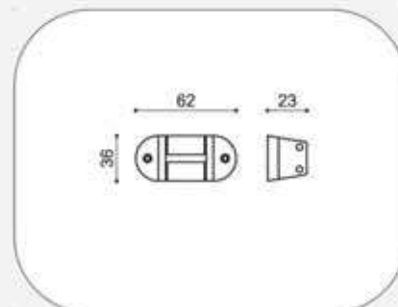

finiture:
OLV ottone lucido verniciato
CS ottone cromato satinato
CR ottone cromato lucido
BG ottone bronzato graffiato

710 Guidacinghie uovo

Ⓑ

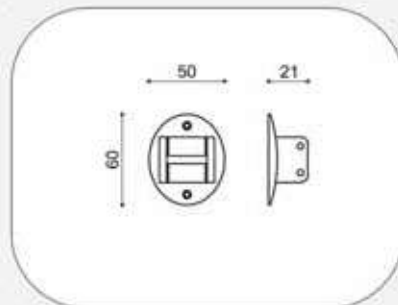

finiture:

- OLV ottone lucido verniciato
- CS ottone cromato satinato
- CR ottone cromato lucido
- BG ottone bronzato graffiato

106 Gancio sicurezza Roma

Ⓑ

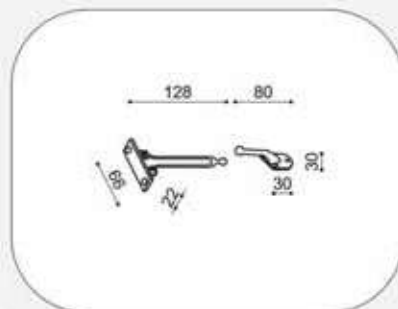

finiture:

- OL ottone lucido
- CS ottone cromato satinato
- CR ottone cromato lucido
- BU ottone bronzato uniforme

101 Cricchetto sopra luce

(B)

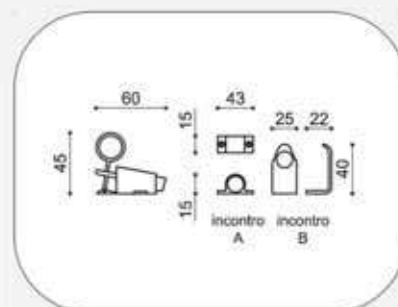

101 : cricchetto
 101A : incontro tipo A
 101B : incontro tipo B

finiture:
 OL : ottone lucido
 CS : ottone cromato satinato
 CR : ottone cromato lucido
 BU : ottone bronzato uniforme

102 Pinza fermaporta

(B)

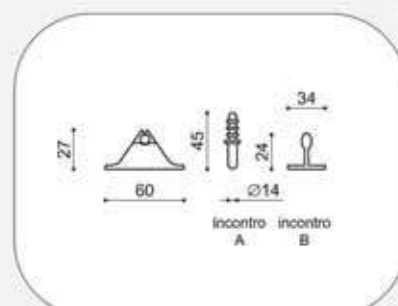

102 : pinza
 102A : incontro tipo A
 102B : incontro tipo B

finiture:
 OL : ottone lucido
 CS : ottone cromato satinato
 CR : ottone cromato lucido
 BU : ottone bronzato uniforme

104

Maniglia blocco leggera

(B)



immagine maniglia sinistra

104DX : destra
104SX : sinistra

finiture:

OL ottone lucido
CS ottone cromato satinato
CR ottone cromato lucido
BU ottone bronzato uniforme

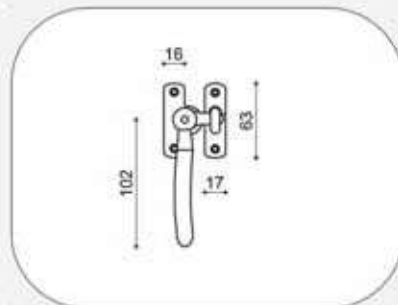
105

Maniglia blocco pesante

(B)



immagine maniglia sinistra

105DX : destra
105SX : sinistra

finiture:

OL ottone lucido
CS ottone cromato satinato
CR ottone cromato lucido
BU ottone bronzato uniforme

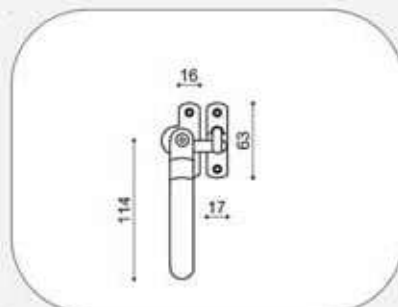
165_{R45}

Pomolino olivetta su ros. tonda

ⓑ

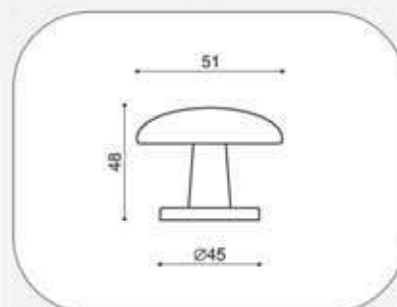

completo di quadro 8x80

finiture:

- OLV ottone lucido verniciato
- SV ottone satinato verniciato
- CS ottone cromato satinato
- CR ottone cromato lucido
- BG ottone bronzato graffiato

165_{RO}

Pomolino olivetta su ros. ovale

ⓑ

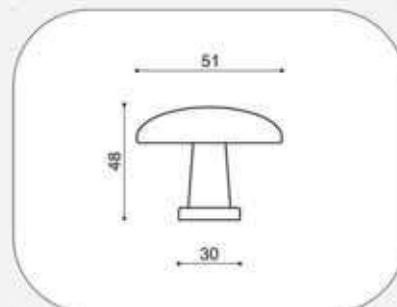

completo di quadro 8x80

finiture:

- OLV ottone lucido verniciato
- SV ottone satinato verniciato
- CS ottone cromato satinato
- CR ottone cromato lucido
- BG ottone bronzato graffiato

156_{R45}

Pomolo ovotto su ros. tonda

Ⓑ

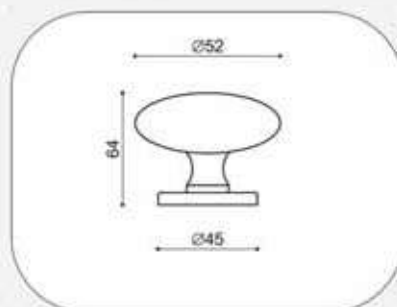

completo di quadro 8x80

finiture:

- OLV ottone lucido verniciato
- SV ottone satinato verniciato
- CS ottone cromato satinato
- CR ottone cromato lucido
- BG ottone bronzato graffiato

156_{RO}

Pomolo ovotto su ros. ovale

Ⓑ

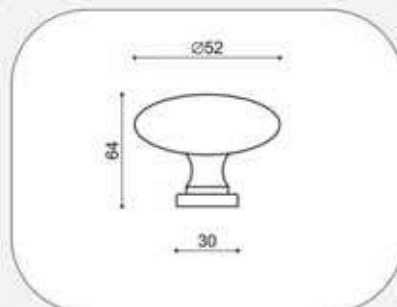

completo di quadro 8x80

disponibile su richiesta con mov. DK

finiture:

- OLV ottone lucido verniciato
- SV ottone satinato verniciato
- CS ottone cromato satinato
- CR ottone cromato lucido
- BG ottone bronzato graffiato

160_{MRO}

Martellina bastone su ros. ovale

ⓑ



completo di quadro 8x80

disponibile su richiesta con mov. DK

finiture:

OLV	ottone lucido verniciato
SV	ottone satinato verniciato
CS	ottone cromato satinato
CR	ottone cromato lucido
BG	ottone bronzato graffiato

70_{MRO}

Martellina pendente su ros. ovale

ⓑ

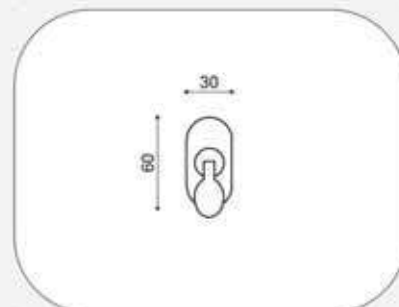

completo di quadro 8x80

finiture:

OLV	ottone lucido verniciato
SV	ottone satinato verniciato
CS	ottone cromato satinato
CR	ottone cromato lucido
BG	ottone bronzato graffiato

3109

Catenaccio a cremagliera

(B)

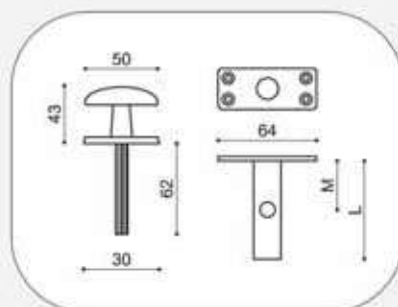

varianti:

3109 60 : M 32 mm - L 60 mm
3109 80 : M 42 mm - L 80 mm

finiture:

OLV ottone lucido verniciato
CS ottone cromato satinato
CR ottone cromato lucido
BG ottone bronzato graffiato

3110

Maniglia con anello

(M) (B)

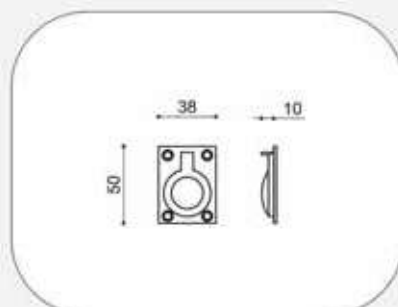

finiture:

OLV ottone lucido verniciato
CS ottone cromato satinato
CR ottone cromato lucido
BR ottone bronzato

MORO maritech oro lucido
MCS maritech cromato satinato

128

Cappuccio in ottone copricerniera

ⓑ

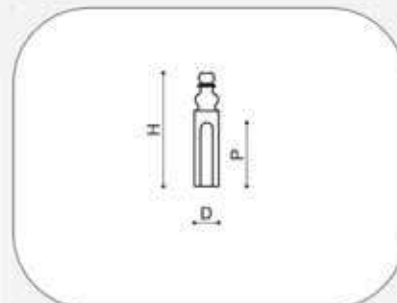

versioni:

12814 : H 71 mm - P 40 mm - D interno 14 mm
12816 : H 72 mm - P 41 mm - D interno 16 mm
12820 : H 95 mm - P 57 mm - D interno 20 mm

finiture:

OLV ottone lucido verniciato
SV ottone satinato verniciato
CS ottone cromato satinato
CR ottone cromato lucido
ANT ottone bronzo antico
ORO ottone oro antico
ARG ottone argento antico
RAM ottone ramato antico
BG ottone bronzato graffiato

129

Cappuccio in ottone copricerniera

ⓑ

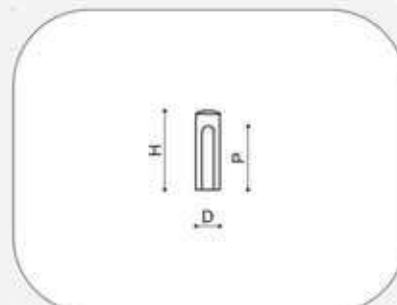

versioni:

12914 : H 49 mm - P 40 mm - D interno 14 mm
12916 : H 52 mm - P 41 mm - D interno 16 mm

finiture:

OLV ottone lucido verniciato
SV ottone satinato verniciato
CS ottone cromato satinato
CR ottone cromato lucido
ANT ottone bronzo antico
ORO ottone oro antico
ARG ottone argento antico
RAM ottone ramato antico
BG ottone bronzato graffiato

132 Kit Dk sicurezza con rosetta ovale

ⓑ

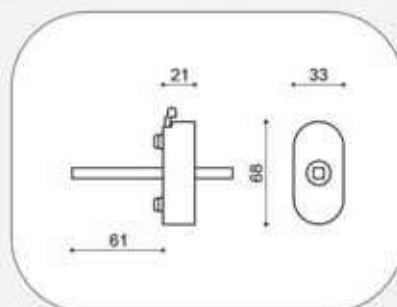

N.B.
Abbinabile a qualsiasi maniglia con modifica
sul collo fresando il vasetto

finiture:
OLV ottone lucido verniciato
CS ottone cromato satinato

133 Kit Dk sicurezza con ros. rettangolare



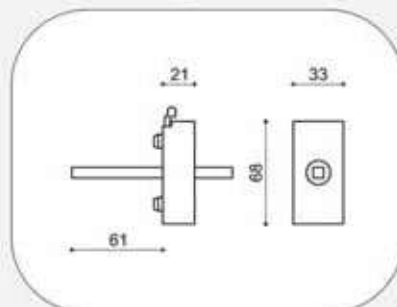







ⓑ



N.B.
Abbinabile a qualsiasi maniglia con modifica
sul collo fresando il vasetto

finiture:
CS ottone cromato satinato
CR ottone cromato lucido

Accessori

- | | | | |
|---|-----------------------------------|--|---|
|  | Rosette
<i>pag. 361</i> |  | Rosette
<i>pag. 362</i> |
|  | Rosette
<i>pag. 363</i> |  | Mov. Dry Keep
<i>pag. 364</i> |
| | |  | Mov. cremonesi
<i>pag. 365</i> |
| | |  | Quadri
<i>pag. 366</i> |
| | |  | Quadri
<i>pag. 367</i> |
|  | Placche
<i>pag. 358</i> |  | Attacchi e molle
<i>pag. 368</i> |
|  | Placche
<i>pag. 359</i> |  | Riduzioni e ranelle
<i>pag. 369</i> |
|  | Rosette
<i>pag. 360</i> |  | Brugole e viti
<i>pag. 370</i> |

Placche per maniglie



P101:
placca per maniglia a 4 fori
distanza 90-70-Yale-foro WC



P102:
placca per maniglia a 2 fori
distanza 90-70-Yale-foro WC



P103:
placca per maniglia larga 4 fori
distanza 90-70-Yale



P104:
placca per maniglia stretta
distanza 90-Yale



P105:
placca per maniglia rettangolare
distanza 70-90-Yale
[**articolo su richiesta**](#)

Placche per martellina / cremonese



P106:
placca tonda per martellina



P107:
placca per martellina grande



P108:
placca per martellina senza fori vite



P109:
placca rettangolare per martellina

Rosette e bocchette Ø 50 mm



1500-16:
rosetta tonda d. 50x10mm
con foro d. 16 mm
**su richiesta disponibili le
bocchette in abbinato d.50mm*



1500-24:
rosetta tonda d. 52x10mm
con foro d. 24 mm



1500-C:
rosetta tonda d. 52x10mm
con foro chiave ovale



1500-Y:
rosetta tonda d. 52x10mm con
foro chiave yale

Rosette e bocchette Ø 48 mm



1570:
rosetta tonda D.48x7mm
con foro D.16 mm



1572:
rosetta tonda D.48x7mm
con foro D.24 mm



1574:
bocchetta tonda D.48x7mm
con foro chiave ovale



1576:
bocchetta tonda D.48x7mm
con foro yale

Rosette e bocchette bombate



2560:
rosetta bombata D.48x11mm
con foro D.16 Tornita



2561:
rosetta bombata D.48x11mm
con foro D.16



2562:
bocchetta bombata D.48x11mm
con foro chiave ovale



2563:
bocchetta bombata
D.48x11mm con foro yale

Rosette e bocchette Ø 45 mm



1560A:
rosetta tonda D.45x10,5
mm con foro D.18mm
tomita



1560B:
rosetta tonda D.45x9 mm
con foro D.22mm



1560C:
rosetta tonda D.45x9 mm
con foro D.24mm



1561:
bocchetta tonda D.45x7mm
foro yale



1562:
bocchetta tonda D.45x7mm
foro chiave ovale



1563:
bocchetta tonda D.45x7mm
cieca



1564:
bocchetta tonda D.45x7mm
foro doppia mappa



1565:
bocchetta tonda D.45x7mm
foro union

Rosette e bocchette ovali



1530A:
rosetta ovale per DK
65x30mm foro D.16mm



1530B:
rosetta ovale 60x30mm
foro D.24mm



1540:
bocchetta ovale 60x30mm
foro chiave ovale



1540U:
bocchetta ovale 60x30mm
foro union



1555:
bocchetta ovale 60x30mm
foro yale



1550:
bocchetta ovale 60x30mm
cieca

Rosette e bocchette quadre 50x50mm



3565:
rosetta quadra 50x50mm
con foro D.16mm



3566:
bocchetta quadra 50x50mm
con foro chiave ovale



3567:
bocchetta quadra 50x50mm
con foro yale

Rosette e bocchette quadre 45x45mm



3560:
rosetta quadra 45x45mm
con foro D.16mm



3561:
bocchetta quadra 45x45mm
con foro chiave ovale



3562:
bocchetta quadra 45x45mm
con foro yale

Rosette e bocchette rettangolari



1530R:
rosetta rettangolare
65x30mm foro D.16mm



1540R:
bocchetta rettangolare
60x30mm foro chiave ovale



1550R:
bocchetta rettangolare
60x30mm foro yale

Rosette e bocchette lusso



1570L:
rosetta tonda ad avvitare
lusso D. 50x10mm foro
tondo d. 16mm



1572L:
rosetta tonda ad avvitare
lusso D. 50x10mm foro
chiave ovale



1574L:
rosetta tonda ad avvitare
lusso D. 50x10mm foro
chiave yale

Rosette e bocchette lusso smussate



1570LS:
rosetta tonda ad avvitare
lusso smussata D. 50x10mm
foro tondo d. 16mm



1572LS:
rosetta tonda ad avvitare
lusso smussata D. 50x10mm
foro chiave ovale



1574LS:
rosetta tonda ad avvitare lusso
smussata D. 50x10mm foro
chiave yale

Rosoni



R80:
rosone tondo per pomolo
D.80mm

Movimenti Dry Keep



1660:
movimento DK 7x36 senza
bussole



1661:
movimento DK 7x36 con
bussole



1662:
movimento DK fisso con
bussole



1664:
movimento DK fisso senza
bussole



1665:
movimento DK 7x42 in
nylon con bussole



1666:
movimento DK 7x42 in nylon
con bussole 8 scatti



1670:
movimento DK 7x42 senza
bussole



1672:
movimento DK 7x42 con
bussole



1673:
movimento DK 7x42 a filo
con bussole



1674:
movimento DK 7x80 a filo
con bussole



1675:
movimento DK 7x55 con
bussole



1676:
movimento DK 7x55 senza
bussole



1677:
movimento DK di sicurezza con boccole
pulsante: cromo sat ,oro lucido

N.B.:

I movimenti Dry keep sono disponibili anche ad 8 scatti per la micro areazione

Movimenti Cremonesi / Martelline



M1551:
movimento gratz con
bussole
quadro lato maniglia 7x7



M1552:
movimento gratz con
bussole più quadro 7
quadro lato maniglia 7x7



M1553:
movimento gratz con fori
quadro lato maniglia 7x7



M1554:
movimento gratz con fori
più quadro 7
quadro lato maniglia 7x7



M1555:
movimento gratz con perni
quadro lato maniglia 7x7



M1556:
movimento gratz con perni
più quadro 7
quadro lato maniglia 7x7



M1551-6:
movimento gratz con bussole
quadro lato maniglia 6x6



M1553-6:
movimento gratz con fori
quadro lato maniglia 6x6



M1555-6:
movimento gratz con perni
quadro lato maniglia 6x6



M1557:
movimento MP per aste
esterne
quadro lato maniglia 6x6



M1558:
movimento MP perni
lunghi
quadro lato maniglia 7x7



M1559:
movimento martellina
rinforzato
quadro lato maniglia 7x7



M1551R:
movimento gratz con
bussole rinforzato
quadro lato maniglia 7x7



M1553R:
movimento gratz con fori
rinforzato
quadro lato maniglia 7x7



M1555R:
movimento gratz con perni
rinforzato
quadro lato maniglia 7x7

Quadri per maniglia

1915 72:

quadro 8x72mm per maniglia con 2 tagli

1915 75:

quadro 8x75mm per maniglia con 2 tagli

1915 80:

quadro 8x80mm per maniglia con 2 tagli

1915 85:

quadro 8x85mm per maniglia con 2 tagli

1915 90:

quadro 8x90mm per maniglia con 2 tagli

1915 100:

quadro 8x100mm per maniglia con 2 tagli

1915 105:

quadro 8x105mm per maniglia con 2 tagli

1915 110:

quadro 8x110mm per maniglia con 2 tagli

1915 115:

quadro 8x115mm per maniglia con 2 tagli

1915 120:

quadro 8x120mm per maniglia con 2 tagli

1915 130:

quadro 8x130mm per maniglia con 2 tagli

1915 140:

quadro 8x140mm per maniglia con 2 tagli

1915 150:

quadro 8x150mm per maniglia con 2 tagli

1915 160:

quadro 8x160mm per maniglia con 2 tagli



Quadri



1903 65:
quadro ad espansione
8x65mm



1903 80:
quadro ad espansione
8x80mm



1903 90:
quadro ad espansione
8x90mm



1920:
quadro 8x100mm con
niples M10



1921:
quadro 8x100mm con
niples M12



1922:
quadro 8x100mm con
niples M14



QM:
quadro 8x100mm con
molla quadra



1923:
quadro 8x90mm con
piastrina quadro 8x8



1923T:
quadro 8x90mm con
piastrina ovale quadro 8x8



1924:
quadro 8x90mm con
piastrina filetto M8



1924T:
quadro 8x90mm con
piastrina ovale filetto M8



1902:
quadro 7x60mm con
cianfratura



1909:
quadro 7x80mm con
cianfratura



1911:
quadro 7x70mm liscio



1912:
quadro speciale per
movimeto Dk fisso



1905:
quadro 10x70 smussato



1906:
quadro 10x100 smussato



1913:
quadro 10x130 smussato

Attacchi e molle



1601:
attacco con estremità filettata M8



1601T:
attacco ovale con estremità filettata M8



1602:
attacco con estremità Q8



1602T:
attacco ovale con estremità filettata Q8



1603:
attacco per maniglioni



1604:
attacco per maniglioni a coppia



1605:
troncone a mordente M8 con fischer



1606:
troncone a mordente M10 con fischer



1607:
riduzione interno M8 esterno M12



1608:
riduzione interno M8 esterno M12



1609:
riduzione interno Q.8 esterno M14



1610:
riduzione interno quadro 8 esterno M14



1611:
kit di fissaggio per pomolo



1612:
molla ambidestra in metallo con esterno filettato



1613:
molla bombata in nylon con alette



1614:
molla bombata in nylon con quadro 8



1615:
molla quadra 45x45 in nylon con alette



1616:
molla quadra 45x45 in nylon con quadro 8



1617:
molla quadra 50x50 in nylon con alette



1618:
molla quadra 50x50 in nylon con quadro 8



1619:
centratore per art. 1617/1615



1620:
molla a chiodo

Riduzioni e ranelle



1641:
riduzione da 6 a 8 x20 in metallo



1642:
riduzione da 6 a 8 x15 in metallo



1643:
riduzione da 7 a 8 x20 in metallo



1644:
riduzione da 6 a 7 x 20 in metallo



1645:
riduzione da 8 a 9 x 20 in metallo



1646:
riduzione da 6 a 8 x 30 in nylon



1647:
riduzione da 7 a 8 x 30 in nylon



1629:
ranello 16x19x0,5mm color oro



1630:
ranello 16x19x1mm color oro



1631:
ranello 6x19x0,5mm color bianco



1632:
ranello 16x19x1mm color bianco



1633:
ranello 16x21x0,5mm color oro



1634:
ranello 16x21x1mm color oro



1635:
ranello 16x19x1mm color nero



1636:
ranello 16x19x1mm a T color nero



1637:
ranello per DK fisso color oro



1638:
ranello per DK fisso color bianco



1639:
ranello per cremonese color oro



1640:
ranello per ovalino mp color oro



1640M:
ranello ondulato in metallo



1640L:
ranello per alzante scorrevole nera

Brugole e viti di fissaggio



1621:
grano con esagono M5x5 e chiavetta



1623:
grano con esagono M5x8 e chiavetta



1625:
2 grani con esagono M6x8 e chiavetta



1627:
2 grani con esagono M6x14 e chiavetta



1622:
2 grani con esagono M5x6 e chiavetta



1624:
2 grani con esagono M6x6 e chiavetta



1626:
grano con esagono M4x5 e chiavetta



1628:
vite con esagono M4x12 e chiavetta
color oro - cromo



1730:
kit viti e fischer per supporto art. 107
color oro - bronzo - cromo



1732:
kit 8 viti per maniglia su placca
color oro - bronzo - cromo



1734:
kit 4 viti per serratura porta scorrevole
color oro - bronzo - cromo



1731:
kit 2 viti per supporto tondo
color oro - bronzo - cromo



1733:
kit 4 viti per maniglia su placca / martellina
color oro - bronzo - cromo



1739:
kit 10 viti per maniglia su rosetta



1750:
vite con testa cilindro con esagono
M5x70



1752:
vite con testa a croce seghettata
M5x90



1751:
vite con testa cilindro con esagono
M5x110



1753:
vite di giunzione con incontro regolabile
M4x80 incontro L: 20mm

Marchiatura

Grazie a nuovi macchinari si possono realizzare marchi a tampone personalizzati su qualsiasi articolo e su qualsiasi finitura.



— Blister



Blister

Mariva Srl offre la possibilità di confezionare ogni articolo in pratici e comodi blister.
(quantitativi minimi da concordare con l'azienda)



Espositori



Espositori

Si realizzano su richiesta diversi tipi di espositore: a parete, portatile, girevole per soddisfare le esigenze di spazio di tutti i nostri clienti.



confezioni



— confezioni



indice alfanumerico

articolo	descrizione	pagina
art. 101	Cricchetto sopraluce	pag. 348
art. 102	Pinza	pag. 348
art. 103	Supporto	pag. 240
art. 104	Maniglia blocco leggera	pag. 349
art. 105	Maniglia blocco pesante	pag. 349
art. 1050	Onda	pag. 104
art. 1054F	Kit tondo per scorrevoli	pag. 284
art. 1055	Ines	pag. 105
art. 106	Gancio Roma	pag. 347
art. 1060	Alfa	pag. 106
art. 1060B	Alfa B	pag. 107
art. 1062B	Luna B	pag. 108
art. 1062T	Attacco	pag. 368
art. 1064	Kit tondo per scorrevoli	pag. 281
art. 107	Supporto	pag. 240
art. 1074	Kit tondo per scorrevoli	pag. 276
art. 1074F	Kit tondo per scorrevoli	pag. 284
art. 108	Supporto	pag. 241
art. 108C	Supporto	pag. 241
art. 109	Supporto	pag. 242
art. 110	Supporto	pag. 242
art. 1101	Numero	pag. 343
art. 1103	Numero	pag. 343
art. 111	Supporto	pag. 243
art. 1110	Giada	pag. 109
art. 1115	Tube per corr.	pag. 246
art. 112	Supporto	pag. 243
art. 1125	Rugiada	pag. 110
art. 1126	Sidney	pag. 111
art. 1127	Nuvola	pag. 34
art. 1127	Nuvola	pag. 52
art. 1127	Nuvola	pag. 112
art. 1127B	Nuvola B	pag. 35
art. 1127B	Nuvola B	pag. 53
art. 1127B	Nuvola B	pag. 113
art. 1128	Asia	pag. 114
art. 1129	Arianna	pag. 36
art. 1129	Arianna	pag. 115
art. 113	Supporto	pag. 244
art. 1130	Kioto	pag. 37
art. 1130	Kioto	pag. 62
art. 114	Supporto	pag. 244
art. 115	Supporto per tubo	pag. 245
art. 116	Supporto per tubo	pag. 245
art. 1179	Viareggio	pag. 119
art. 119	Finale per tubo	pag. 246
art. 120	Seven	pag. 216
art. 1200	Bocchetta tonda	pag. 234
art. 1210	Bocchetta tonda	pag. 234

articolo	descrizione	pagina
art. 1230	Bocchetta tonda	pag. 235
art. 1235	Bocchetta ovale	pag. 235
art. 125	Anello	pag. 216
art. 126	Spigola	pag. 196
art. 1260	Uovo	pag. 116
art. 1260C	coppia Uovo	pag. 213
art. 126C	coppia Spigola	pag. 208
art. 127	Spigola small	pag. 196
art. 127C	coppia Spigola small	pag. 208
art. 128	Cappuccio in ottone	pag. 354
art. 129	Cappuccio in ottone	pag. 354
art. 130	Margherita	pag. 217
art. 132	Kit DK di sicurezza	pag. 355
art. 133	Kit DK di sicurezza	pag. 355
art. 135	Barocco	pag. 217
art. 136	Square	pag. 197
art. 136C	coppia Square	pag. 209
art. 137	Cubo	pag. 197
art. 137C	coppia Cubo	pag. 209
art. 138	Spirit	pag. 198
art. 138PY	Spirit PY	pag. 173
art. 139	Lunik	pag. 198
art. 139C	coppia Lunik	pag. 210
art. 140	Classic	pag. 218
art. 141	Sfera	pag. 199
art. 141C	coppia Sfera	pag. 210
art. 142	Cipolla	pag. 199
art. 142C	coppia Cipolla	pag. 211
art. 14365	Ideal 65	pag. 200
art. 14375	Ideal 75	pag. 200
art. 144	Special	pag. 201
art. 145	Lion	pag. 218
art. 148	Miriam	pag. 84
art. 148B	Miriam B	pag. 85
art. 149	Urano	pag. 201
art. 150	Adry	pag. 86
art. 1500-16	Rosetta D. 50 mm	pag. 360
art. 1500-24	Rosetta D. 50 mm	pag. 360
art. 1500-C	Bocchetta D. 50 mm	pag. 360
art. 1500-Y	Bocchetta D. 50 mm	pag. 360
art. 1501	Bocchetta	pag. 224
art. 1502	Bocchetta	pag. 225
art. 1503	Bocchetta	pag. 225
art. 1505	Piacchetta	pag. 226
art. 1506	Piacchetta	pag. 226
art. 1507	Piacchetta	pag. 227
art. 1508	Piacchetta	pag. 227
art. 1509	Piacchetta	pag. 228
art. 151	Mondial	pag. 87

indice alfanumerico

articolo	descrizione	pagina
art. 1510	Placchetta	pag. 228
art. 1511	Placchetta	pag. 229
art. 1521	Pomolo	pag. 231
art. 1522	Pomolo	pag. 232
art. 1523	Pomolino	pag. 232
art. 153	Smart	pag. 202
art. 153	Smart	pag. 230
art. 1530A	Rosetta ovale	pag. 361
art. 1530B	Rosetta ovale	pag. 361
art. 1530R	Rosetta rettangolare	pag. 362
art. 153C	coppia Smart	pag. 211
art. 1540	Bocchetta ovale	pag. 361
art. 1540R	Bocchetta rettangolare	pag. 362
art. 1540U	Bocchetta ovale	pag. 361
art. 155	Lux	pag. 202
art. 155	Lux	pag. 231
art. 1550	Bocchetta ovale	pag. 361
art. 1550R	Bocchetta rettangolare	pag. 362
art. 1555	Bocchetta ovale	pag. 361
art. 155C	coppia Lux	pag. 212
art. 156	Ovotto	pag. 203
art. 156	Ovotto	pag. 229
art. 1560A	Rosetta D. 45 mm	pag. 361
art. 1560B	Rosetta D. 45 mm	pag. 361
art. 1560C	Rosetta D. 45 mm	pag. 361
art. 1561	Bocchetta D. 45 mm	pag. 361
art. 1562	Bocchetta D. 45 mm	pag. 361
art. 1563	Bocchetta D. 45 mm	pag. 361
art. 1564	Bocchetta D. 45 mm	pag. 361
art. 1565	Bocchetta D. 45 mm	pag. 361
art. 156C	Coppia Ovotto	pag. 212
art. 156R45	Pomolo su rosetta	pag. 351
art. 156RO	Pomolo su rosetta	pag. 351
art. 157	Zaffiro	pag. 203
art. 1570	Rosetta D. 48 mm	pag. 360
art. 1570L	Rosetta lusso	pag. 363
art. 1570LS	Rosetta lusso smussata	pag. 363
art. 1572	Rosetta D. 48 mm	pag. 360
art. 1572L	Bocchetta Lusso	pag. 363
art. 1572LS	Bocchetta lusso smussata	pag. 363
art. 1574	Bocchetta D. 48 mm	pag. 360
art. 1574L	Bocchetta Lusso	pag. 363
art. 1574LS	Bocchetta lusso smussata	pag. 363
art. 1576	Bocchetta D. 48 mm	pag. 360
art. 158	Smeraldo	pag. 204
art. 159	Cristal	pag. 204
art. 159RS	Cristal RS	pag. 205
art. 160	Bastone	pag. 88
art. 1601	Attacco	pag. 368

articolo	descrizione	pagina
art. 1601T	Attacco	pag. 368
art. 1602	Attacco	pag. 368
art. 1603	Attacco	pag. 368
art. 1604	Attacco	pag. 368
art. 1605	Troncone	pag. 368
art. 1606	Troncone	pag. 368
art. 1607	Riduzione	pag. 368
art. 1608	Riduzione	pag. 368
art. 1609	Riduzione	pag. 368
art. 160MRO	Pomolo su rosetta	pag. 352
art. 160P	Bastone pesante	pag. 89
art. 161	Ovalino MP	pag. 126
art. 1610	Riduzione	pag. 368
art. 1611	Kit fissaggio	pag. 368
art. 1612	Molla	pag. 368
art. 1613	Molla	pag. 368
art. 1614	Molla	pag. 368
art. 1615	Molla	pag. 368
art. 1616	Molla	pag. 368
art. 1617	Molla	pag. 368
art. 1618	Molla	pag. 368
art. 1619	Centratore per maniglie	pag. 368
art. 161T	Ovalino MP	pag. 127
art. 162	Incontro ovalino	pag. 128
art. 1620	Molla	pag. 368
art. 1621	Chiavetta e grano	pag. 370
art. 1622	Chiavetta e grani	pag. 370
art. 1623	Chiavetta e grano	pag. 370
art. 1624	Chiavetta e grani	pag. 370
art. 1625	Chiavetta e grani	pag. 370
art. 1626	Chiavetta e grani	pag. 370
art. 1627	Chiavetta e grani	pag. 370
art. 1628	Chiavetta e vite	pag. 370
art. 1629	Ranella	pag. 369
art. 163	Ovalino R	pag. 128
art. 1630	Ranella	pag. 369
art. 1631	Ranella	pag. 369
art. 1632	Ranella	pag. 369
art. 1633	Ranella	pag. 369
art. 1634	Ranella	pag. 369
art. 1635	Ranella	pag. 369
art. 1636	Ranella	pag. 369
art. 1637	Ranella	pag. 369
art. 1638	Ranella	pag. 369
art. 1639	Ranella	pag. 369
art. 164	Anello salva muro	pag. 125
art. 1640	Ranella	pag. 369
art. 1640L	Ranella	pag. 369
art. 1640M	Ranella	pag. 369

indice alfanumerico

articolo	descrizione	pagina
art. 1641	Riduzione	pag. 369
art. 1642	Riduzione	pag. 369
art. 1643	Riduzione	pag. 369
art. 1644	Riduzione	pag. 369
art. 1645	Riduzione	pag. 369
art. 1646	Riduzione	pag. 369
art. 1647	Riduzione	pag. 369
art. 165	Olivetta	pag. 230
art. 165R45	Pomolo su rosetta	pag. 350
art. 165RO	Pomolo su rosetta	pag. 350
art. 1660	Movimento DK	pag. 364
art. 1661	Movimento DK	pag. 364
art. 1662	Movimento DK	pag. 364
art. 1664	Movimento DK	pag. 364
art. 1665	Movimento DK	pag. 364
art. 1666	Movimento DK	pag. 364
art. 167	Margherita	pag. 205
art. 1670	Movimento DK	pag. 364
art. 1672	Movimento DK	pag. 364
art. 1673	Movimento DK	pag. 364
art. 1674	Movimento DK	pag. 364
art. 1675	Movimento DK	pag. 364
art. 1676	Movimento DK	pag. 364
art. 1677	Movimento DK	pag. 364
art. 1680	Serratura per scorrevoli	pag. 298
art. 1680c	Chiave snodata	pag. 301
art. 1680cc	Chiave snodata	pag. 301
art. 1680Y	Serratura per scorrevoli	pag. 298
art. 1690	Serratura per scorrevoli	pag. 299
art. 1690i	Incontro per scorrevoli	pag. 299
art. 1690iC	Incontro per scorrevoli	pag. 300
art. 1690iL	Incontro per scorrevoli	pag. 300
art. 1705	Nottolino WC	pag. 322
art. 1706	Nottolino WC	pag. 322
art. 1707	Nottolino WC	pag. 323
art. 1708	Nottolino WC	pag. 323
art. 1709	Nottolino WC	pag. 324
art. 1710	Nottolino WC	pag. 324
art. 1711	Nottolino WC	pag. 325
art. 1712	Nottolino WC	pag. 325
art. 1713	Nottolino WC	pag. 326
art. 1714	Nottolino WC	pag. 326
art. 1715	Nottolino WC	pag. 327
art. 1716	Nottolino WC	pag. 327
art. 1717	Nottolino WC	pag. 328
art. 1718	Nottolino WC	pag. 328
art. 1719	Nottolino WC	pag. 329
art. 1721	Nottolino WC	pag. 329
art. 1730	Viti	pag. 370

articolo	descrizione	pagina
art. 1731	Viti	pag. 370
art. 1732	Viti	pag. 370
art. 1733	Viti	pag. 370
art. 1734	Viti	pag. 370
art. 1735	Nottolino WC	pag. 330
art. 1735slim	Wc tondo	pag. 57
art. 1736	Nottolino WC	pag. 330
art. 1739	Viti	pag. 370
art. 1740	Nottolino WC	pag. 331
art. 1740slim	Wc tondo	pag. 57
art. 1741	Nottolino WC	pag. 331
art. 1746	Nottolino WC	pag. 332
art. 1747	Nottolino WC	pag. 332
art. 1748	Nottolino WC	pag. 333
art. 1749	Nottolino WC	pag. 333
art. 1750	Viti	pag. 370
art. 1751	Viti	pag. 370
art. 1752	Viti	pag. 370
art. 1753	Viti	pag. 370
art. 1770	Ginevra	pag. 63
art. 1775	Aurelia	pag. 117
art. 1776	Ottocento	pag. 64
art. 1777	Firenze	pag. 65
art. 1778	Torino	pag. 118
art. 179	CB collo basso	pag. 124
art. 1790	Sofia	pag. 120
art. 1791	Diamantea	pag. 121
art. 1792	Camelia	pag. 122
art. 1793	Scalea	pag. 123
art. 180	Studio	pag. 132
art. 1800	Supporto easy	pag. 247
art. 1805	Anello di giunzione	pag. 247
art. 181	Studio zancato	pag. 133
art. 1810	Finale con vite	pag. 248
art. 1815	Finale con vite	pag. 248
art. 1816	Supp. per corda	pag. 249
art. 1817	Finale per corda	pag. 249
art. 182	Stilo	pag. 134
art. 183	Stilo lungo	pag. 135
art. 190	Lotus	pag. 136
art. 1902	Quadro	pag. 367
art. 1903	Quadro esp.	pag. 233
art. 190365	Quadro	pag. 367
art. 190380	Quadro	pag. 367
art. 190390	Quadro	pag. 367
art. 1905	Quadro	pag. 367
art. 1906	Quadro	pag. 367
art. 1909	Quadro	pag. 367
art. 191	Sonic	pag. 137

indice alfanumerico

articolo	descrizione	pagina
art. 1911	Quadro	pag. 367
art. 1912	Quadro	pag. 367
art. 1913	Quadro	pag. 367
art. 1915	Quadro per maniglia	pag. 366
art. 192	Square	pag. 138
art. 1920	Quadro riples	pag. 233
art. 1920	Quadro riples	pag. 367
art. 1921	Quadro	pag. 367
art. 1922	Quadro	pag. 367
art. 1923	Quadro	pag. 367
art. 1923T	Quadro	pag. 367
art. 1924	Quadro	pag. 367
art. 1924T	Quadro	pag. 367
art. 193	Zonta	pag. 139
art. 194	Honey	pag. 140
art. 195	Tesa	pag. 141
art. 196	Nives	pag. 142
art. 200	Apollo	pag. 143
art. 2000	Royal	pag. 182
art. 2000B	Royal B	pag. 183
art. 2000R	Royal R	pag. 186
art. 2000Z	Royal Z	pag. 187
art. 2001	Spigola	pag. 178
art. 2001B	Spigola B	pag. 179
art. 2002	Placca Royal	pag. 189
art. 2002Z	Placca Royal Z	pag. 190
art. 2003	Nicchia Royal	pag. 189
art. 2003Z	Nicchia Royal Z	pag. 190
art. 2004	Coppia speciale	pag. 188
art. 2005	Royal Junior	pag. 184
art. 2005B	Royal Junior B	pag. 185
art. 2006	Spigola corto	pag. 180
art. 2006B	Spigola corto B	pag. 181
art. 2007	Placca quadra	pag. 191
art. 2008	Nicchia quadra	pag. 191
art. 200E	Cerniera invisibile	pag. 341
art. 201	Soffio	pag. 144
art. 202	Luna	pag. 145
art. 203	Splendid	pag. 146
art. 203B	Splendid B	pag. 147
art. 204	Adry	pag. 148
art. 205	Garda	pag. 149
art. 2055	Kit tondo per scorrevoli	pag. 278
art. 2056	Kit tondo per scorrevoli	pag. 278
art. 206	Idea	pag. 150
art. 2060	Nicchia tonda per scorrevoli	pag. 313
art. 2061	Ditale di trascinamento	pag. 319
art. 206B	Idea B	pag. 151
art. 207	Classic	pag. 152

articolo	descrizione	pagina
art. 2074	Kit tondo per scorrevoli	pag. 276
art. 208	Eclisse	pag. 153
art. 209	Aurelia	pag. 154
art. 209Z	Aurelia zancato	pag. 155
art. 210	Bingo	pag. 156
art. 2105	Lofus	pag. 38
art. 2106	Trix	pag. 39
art. 2107	Square	pag. 40
art. 2108	Zonta	pag. 41
art. 2109	Honey	pag. 42
art. 2109	Honey	pag. 54
art. 2109	Honey	pag. 66
art. 210B	Bingo B	pag. 157
art. 211	Mito	pag. 158
art. 2110B	Luxury B	pag. 43
art. 2110B	Luxury B	pag. 67
art. 2111B	Prestige B	pag. 44
art. 2111B	Prestige B	pag. 68
art. 2112	Space	pag. 45
art. 2112	Space	pag. 69
art. 2113	Tesa	pag. 55
art. 2113	Tesa	pag. 70
art. 2114	Nives	pag. 56
art. 2114	Nives	pag. 71
art. 211B	Mito B	pag. 159
art. 212200	Arco 200	pag. 160
art. 212300	Arco 300	pag. 161
art. 213	Margherita	pag. 162
art. 2130	Marea	pag. 72
art. 2130B	Marea B	pag. 73
art. 214	Clara	pag. 163
art. 2140	Meganisi	pag. 74
art. 2147	Linzi	pag. 46
art. 2147	Linzi	pag. 75
art. 215	Liso	pag. 164
art. 215B	Liso B	pag. 165
art. 216	Light	pag. 166
art. 217	Easy	pag. 167
art. 218	Spigola	pag. 168
art. 219	Spigola lungo	pag. 169
art. 2260	Sirio	pag. 76
art. 2260C	coppia Sirio	pag. 213
art. 2270B	Paris B	pag. 77
art. 2271B	Scarlet B	pag. 78
art. 2274B	Star B	pag. 79
art. 2275B	Adria B	pag. 80
art. 2560	Rosetta Bombata	pag. 360
art. 2561	Rosetta Bombata	pag. 360
art. 2562	Bocchetta Bombata	pag. 360

indice alfanumerico

articolo	descrizione	pagina
art. 2563	Bocchetta Bombata	pag. 360
art. 300	Bocchetta	pag. 222
art. 301	Bocchetta	pag. 222
art. 302	Piacchetta	pag. 223
art. 303	Piacchetta	pag. 223
art. 304	Piacchetta	pag. 224
art. 3054	Kit quadrato per scorrevoli	pag. 292
art. 3055	Kit quadrato per scorrevoli	pag. 291
art. 3055Y	Kit quadrato per scorrevoli	pag. 295
art. 3056	Kit quadrato per scorrevoli	pag. 291
art. 3060	Nicchia quadrata per scorrevoli	pag. 316
art. 3060B	Nicchia quadrata per scorrevoli	pag. 316
art. 3061	Ditale di trascinamento	pag. 319
art. 3085	Kit quadrato per scorrevoli	pag. 294
art. 3085F	Kit quadrato per scorrevoli	pag. 295
art. 3085i	Kit quadrato per scorrevoli	pag. 292
art. 3085IF	Kit quadrato per scorrevoli	pag. 293
art. 3086	Kit quadrato per scorrevoli	pag. 294
art. 3086i	Kit quadrato per scorrevoli	pag. 293
art. 3109	Catenaccio a cremagliera	pag. 353
art. 3110	Maniglia con anello	pag. 353
art. 3174	Kit quadrato per scorrevoli	pag. 290
art. 3174F	Kit quadrato per scorrevoli	pag. 290
art. 325	Fermaporta	pag. 336
art. 330	Fermaporta	pag. 336
art. 335	Fermaporta	pag. 337
art. 340	Fermaporta	pag. 337
art. 3560	Rosetta quadra 45	pag. 362
art. 3561	Bocchetta quadra 45	pag. 362
art. 3562	Bocchetta quadra 45	pag. 362
art. 3565	Rosetta quadra 50	pag. 362
art. 3566	Bocchetta quadra 50	pag. 362
art. 3567	Bocchetta quadra 50	pag. 362
art. 370	Chiara	pag. 90
art. 380	Cometa	pag. 91
art. 4050	Kit rettangolare per scorrevoli	pag. 253
art. 4051	Kit rettangolare per scorrevoli	pag. 255
art. 4053	Kit rettangolare per scorrevoli	pag. 257
art. 4053C	Kit rettangolare per scorrevoli	pag. 259
art. 4053Y	Kit rettangolare per scorrevoli	pag. 261
art. 4059	Nicchia rettangolare per scorrevoli	pag. 311
art. 4064	Nicchia rettangolare per scorrevoli	pag. 309
art. 4065	Nicchia rettangolare per scorrevoli	pag. 309
art. 4070	Kit rettangolare per scorrevoli	pag. 263
art. 4070B	Kit rettangolare per scorrevoli	pag. 265
art. 4070BC	Kit rettangolare per scorrevoli	pag. 270
art. 4071	Kit rettangolare per scorrevoli	pag. 267
art. 4071B	Kit rettangolare per scorrevoli	pag. 269
art. 4071BC	Kit rettangolare per scorrevoli	pag. 271

articolo	descrizione	pagina
art. 450	Elisa	pag. 92
art. 450B	Elisa B	pag. 93
art. 50	Kit ovale per scorrevoli	pag. 252
art. 5050	Kit ovale per scorrevoli	pag. 252
art. 5051	Kit ovale per scorrevoli	pag. 254
art. 5053	Kit ovale per scorrevoli	pag. 256
art. 5053C	Kit ovale per scorrevoli	pag. 258
art. 5053Y	Kit ovale per scorrevoli	pag. 260
art. 5062	Nicchia ovale per scorrevoli	pag. 307
art. 5063	Nicchia ovale per scorrevoli	pag. 307
art. 5070	Kit ovale per scorrevoli	pag. 262
art. 5070B	Kit ovale per scorrevoli	pag. 264
art. 5071	Kit ovale per scorrevoli	pag. 266
art. 5071B	Kit ovale per scorrevoli	pag. 268
art. 51	Kit ovale per scorrevoli	pag. 254
art. 510	Coprinteruttore	pag. 344
art. 515	Copriavvolgibile	pag. 344
art. 53	Kit ovale per scorrevoli	pag. 256
art. 530	Coprinteruttore	pag. 345
art. 535	Copriavvolgibile	pag. 345
art. 53C	Kit ovale per scorrevoli	pag. 258
art. 53Y	Kit ovale per scorrevoli	pag. 260
art. 54	Kit tondo per scorrevoli	pag. 277
art. 540	Catenaccio	pag. 338
art. 545	Catenaccio	pag. 338
art. 55	Kit tondo per scorrevoli	pag. 279
art. 550	Catenacciolo	pag. 339
art. 555	Catenacciolo	pag. 339
art. 55Y	Kit tondo per scorrevoli	pag. 281
art. 56	Kit tondo per scorrevoli	pag. 279
art. 560	Catenacciolo	pag. 340
art. 565	Catenacciolo	pag. 340
art. 57	Nicchia ovale per scorrevoli	pag. 304
art. 570	Catenacciolo	pag. 341
art. 58	Nicchia ovale per scorrevoli	pag. 304
art. 580	Epoca	pag. 94
art. 580B	Epoca B	pag. 95
art. 59	Nicchia ovale per scorrevoli	pag. 305
art. 60	Nicchia tonda per scorrevoli	pag. 312
art. 60B	Nicchia tonda per scorrevoli	pag. 312
art. 61	Ditale di trascinamento	pag. 318
art. 61P	Ditale di trascinamento	pag. 318
art. 62	Nicchia ovale per scorrevoli	pag. 306
art. 620HG	Staffa HG	pag. 170
art. 620HP	Staffa HP	pag. 172
art. 620HS	Staffa HS	pag. 171
art. 63	Nicchia ovale per scorrevoli	pag. 306
art. 64	Nicchia ovale per scorrevoli	pag. 308
art. 65	Nicchia ovale per scorrevoli	pag. 308

indice alfanumerico

articolo	descrizione	pagina
art. 66	Nicchia ovale per scorrevoli	pag. 310
art. 67	Nicchia ovale per scorrevoli	pag. 310
art. 68	Nicchia rettangolare per scorrevoli	pag. 311
art. 690	Opera	pag. 96
art. 691	Futura	pag. 97
art. 70	Kit ovale per scorrevoli	pag. 262
art. 700	Guidacinghia	pag. 346
art. 705	Guidacinghia	pag. 346
art. 70B	Kit ovale per scorrevoli	pag. 264
art. 70MRO	Pomolo su rosetta	pag. 352
art. 71	Kit ovale per scorrevoli	pag. 266
art. 710	Guidacinghia	pag. 347
art. 71B	Kit ovale per scorrevoli	pag. 268
art. 720	Bucalettera	pag. 342
art. 730	Bucalettera	pag. 342
art. 74	Kit tondo per scorrevoli	pag. 277
art. 755	Antea	pag. 98
art. 755B	Antea B	pag. 99
art. 765	Minerva	pag. 100
art. 765B	Minerva B	pag. 101
art. 766	Spigola	pag. 24
art. 766	Spigola	pag. 60
art. 766B	Spigola B	pag. 25
art. 766B	Spigola B	pag. 61
art. 767	Composita	pag. 26
art. 768	Toga	pag. 27
art. 769	Cuba	pag. 28
art. 769	Cuba	pag. 50
art. 769	Cuba	pag. 102
art. 769B	Cuba B	pag. 29
art. 769B	Cuba B	pag. 51
art. 769B	Cuba B	pag. 103
art. 77	Kit tondo per scorrevoli	pag. 286
art. 770	Milano	pag. 30
art. 771	Monza	pag. 31
art. 77B	Kit tondo per scorrevoli	pag. 286
art. 8050	Kit ovale per scorrevoli	pag. 253
art. 8051	Kit ovale per scorrevoli	pag. 255
art. 8053	Kit ovale per scorrevoli	pag. 257
art. 8053C	Kit ovale per scorrevoli	pag. 259
art. 8053Y	Kit ovale per scorrevoli	pag. 261
art. 8070	Kit ovale per scorrevoli	pag. 263
art. 8070B	Kit ovale per scorrevoli	pag. 265
art. 8070BC	Kit ovale per scorrevoli	pag. 270
art. 8071	Kit ovale per scorrevoli	pag. 267
art. 8071B	Kit ovale per scorrevoli	pag. 269
art. 8071BC	Kit ovale per scorrevoli	pag. 271
art. 81	Kit tondo per scorrevoli	pag. 280
art. 812	Crystal	pag. 32

articolo	descrizione	pagina
art. 813	Shine	pag. 33
art. 82	Kit tondo per scorrevoli	pag. 280
art. 85	Kit tondo per scorrevoli	pag. 282
art. 8532	Kit tondo per scorrevoli	pag. 287
art. 85F	Kit tondo per scorrevoli	pag. 285
art. 85I	Kit tondo per scorrevoli	pag. 283
art. 85IF	Kit tondo per scorrevoli	pag. 285
art. 86	Kit tondo per scorrevoli	pag. 282
art. 8632	Kit tondo per scorrevoli	pag. 287
art. 86I	Kit tondo per scorrevoli	pag. 283
art. 90	Nicchia ovale per scorrevoli	pag. 305
art. 905	Nicchia tonda per scorrevoli	pag. 315
art. 905M	Nicchia tonda per scorrevoli	pag. 315
art. 905Q	Nicchia quadrata per scorrevoli	pag. 317
art. 908	Nicchia tonda per scorrevoli	pag. 313
art. 908Q	Nicchia quadrata per scorrevoli	pag. 317
art. 910	Nicchia tonda per scorrevoli	pag. 314
art. 911	Nicchia tonda per scorrevoli	pag. 314
art. K1	Kit tondo per scorrevoli	pag. 275
art. M1551	Movimento cremonese/martellina	pag. 365
art. M1551-6	Movimento cremonese/martellina	pag. 365
art. M1551R	Movimento cremonese/martellina	pag. 365
art. M1552	Movimento cremonese/martellina	pag. 365
art. M1553	Movimento cremonese/martellina	pag. 365
art. M1553-6	Movimento cremonese/martellina	pag. 365
art. M1553R	Movimento cremonese/martellina	pag. 365
art. M1554	Movimento cremonese/martellina	pag. 365
art. M1555	Movimento cremonese/martellina	pag. 365
art. M1555-6	Movimento cremonese/martellina	pag. 365
art. M1555R	Movimento cremonese/martellina	pag. 365
art. M1556	Movimento cremonese/martellina	pag. 365
art. M1557	Movimento cremonese/martellina	pag. 365
art. M1558	Movimento cremonese/martellina	pag. 365
art. M1559	Movimento cremonese/martellina	pag. 365
art. P101	Placca per maniglie	pag. 358
art. P102	Placca per maniglie	pag. 358
art. P103	Placca per maniglie	pag. 358
art. P104	Placca per maniglie	pag. 358
art. P105	Placca per maniglie	pag. 358
art. P106	Placchetta	pag. 359
art. P107	Placchetta	pag. 359
art. P108	Placchetta	pag. 359
art. P109	Placchetta	pag. 359
art. QM	Quadro	pag. 367
art. R80	Rosone	pag. 363

condizioni generali di vendita

Ordinazioni:

Le ordinazioni devono essere fatte precisando per ogni articolo il numero, la misura, la quantità e l' esecuzione. Non si accettano ordini di quantitativi inferiori al contenuto di ogni singola confezione. Considerando l' alto costo che comporta ogni singola spedizione, non si accettano ordini di importo netto inferiore a € 200.

Termini di consegna:

I termini di consegna indicati sull' ordine si intendono indicativi e non impegnativi.

Spedizioni:

La merce viaggia a rischio e pericolo del committente. Ogni nostra responsabilità cessa al momento della consegna della merce al vettore.

Imballi:

Gli imballi vengono fatturati al costo e non si accettano di ritorno.

Reclami:

Non si accettano reclami dopo il terzo giorno dal ricevimento della merce. Non si accettano resi senza la nostra autorizzazione.

Articoli:

Le misure indicate nei disegni non sono vincolanti, ci riserviamo la facoltà di modificarle senza preavviso.

Condizioni di pagamento:

Le condizioni di pagamento vengono concordate direttamente con il committente. Ove si verifichi il ritorno di insoluti, le spese di protesto e del conto di ritorno sono a carico del committente.

Competenza:

per tutte le controversie che potessero sorgere, direttamente o indirettamente, dal contratto di fornitura, sarà competente il foro di Brescia.

Orders:

Orders must be made specifying number, size, quality and execution for each article. Orders inferior to the contents of each single manufacture will not be accepted.

Delivery terms:

Delivery terms marked on the order are to be intended as indicative and not engaging.

Shipment:

The goods travel under risk and danger of the customer. All our responsibility ceases at the moment of the delivery of the merchandise at the vector. When means that we suppose more convenient.

Packing:

Packing are invoiced at the cost and are not accept on return.

Claims:

Claims are not accepted after the third day of receipt of the merchandise and returns are not accepted without out authorization.

Articles:

The seizes indicated in the design are not binding. We reserve the right to modify them without notice.



Laffranchi group

MARIVA SRL

Via Vallesabbia, 21 - 25076 - Odolo (BS) Italy

C.F. e P.IVA: 02121270983

Tel. +39 0365 826627 - Fax. +39 0365 826327

web: www.marivasrl.com

mail: info@marivasrl.com

EREDI LAFFRANCHI ACHILLE SNC

Sede operativa: Via Vallesabbia, 23/25 - 25076 - Odolo (BS) Italy

Sede legale: Via Disciplina, 11E - 25071 - Agnosine (BS) Italy

C.F.: 00516920170 - P.IVA: 00568870984

Tel. +39 0365 826284 - Fax. +39 0365 869316

web: www.laffranchigroup.com

mail: info@laffranchigroup.com

